

# MMS och CDS

Klordioxid och hälsa



Inklusive  
**VETENSKAPLIGA  
ARTIKLAR**

# MMS och CDS

## Klordioxid och hälsa

Sammanställd av FramSteget

# MMS och CDS

## Klordioxid och hälsa

*Innehållet i denna bok är inte avsedd som medicinsk rådgivning. Den här boken är för information och utbildningssyfte. Vänligen konsultera en läkare när behovet av en sådan indikeras. Av uppenbara skäl kan varken författaren, medförfattare, utgivare, eller medarbetare ta medicinskt eller juridiskt ansvar för om innehållet häri betraktas som ett recept för alla eller någon. Du är ytterst ansvarig för användningsområden i den här boken.*

Kom ihåg att informationen i denna bok fortfarande utvecklas och kommer att fortsätta att förbättras när nya upptäckter görs.

### Källor

Jim Humble

Dr. Andreas Kalcker

Kerri Rivera – Healing the symptoms known as autism

På FramStegets hemsida finns kalkylator för beräkning:

<http://www.framsteget.net/mms-solution>

E-bok publicerad januari 2017.

Kopiera och sprid gärna denna e-bok.

I boken nämns "CD" vilket är en förkortning för klordioxid. Klordioxid är ett väletablerat oxidationsmedel. Klordioxid kallas även ofta för MMS, som är det gemensamma namn Jim Humble gav det. Jim är mannen som upptäckte olika tillämpningar av klordioxid. Det finns många böcker, videor, bloggar och artiklar som använder namnet "MMS" och det är omgivet av en hel del kontroverser. Vi väljer att inte trassla oss in i den debatten eftersom vi fokuserar på att hjälpa människor förbättra sin hälsa. För oss är vår enda angelägenhet att (1) det är säkert för användare och (2) att det fungerar.

Baserat på omfattande användning av MMS och CDS kan vi tryggt säga att ovanstående påståenden är sanna. Om det inte vore så skulle denna bok inte existera.

# Innehåll

En introduktion till klordioxid	6
Om MMS	8
Gör eget MMS	13
CDS - Klordioxidlösning	14
Framställa vs. köpa CDS	16
Några viktiga CDS-punkter	17
Att framställa CDS	18
Mät styrkan på CDS	23
Späda ut HCl-koncentration	26
Från MMS till CDS	27
Att ta CDS (standardprotokoll)	28
Vetenskapliga artiklar	29

# En introduktion till klordioxid

Av Jim Humble

## Några grundläggande punkter

Klordioxid (molekylen) upptäcktes 1814 men många ger äran till Sir Humphrey Davy för dess tillkomst. Idag finns flera patent för att läka olika sjukdomar med klordioxid.

## MMS (Master Mineral Solution)

Jag återupptäckte klordioxid (ClO<sub>2</sub>) 1996 och sedan dess har mer än 1020 personer rest från över 95 länder till Dominikanska republiken, Mexiko och andra länder för att utbildas i dess användning. Vi uppskattar att mer än 10 miljoner människor världen över har använt klordioxid.

Klordioxidmolekylen är den svagaste av alla oxidanter som används i den mänskliga kroppen. Den har därmed mycket liten effekt på mänskliga celler. Denna molekyl har en unik förmåga att känna igen och oxidera (döda) skadliga bakterier. Christian Gram, en vetenskapsman från 1800-talet, upptäckte att de flesta skadliga bakterier har en negativ laddning. Han kunde färga positiva och negativa bakterier med två olika färger. Hans tekniker används fortfarande i laboratorier och universitet. Alla oxidanter, inklusive klordioxid, har en positiv laddning som lockar och dödar negativt laddade bakterier medan de avvärjer positivt laddade bakterier. Klordioxid kan sålunda döda skadliga bakterier utan att förstöra de goda bakterierna. Detta är enkel vetenskap; lika laddningar stöter bort och olika attraherar.

De flesta kemikalier och många livsmedel i vårt samhälle testas för att bestämma deras giftindex. Det betecknas genom att ge

dem en toxicitets nummer kallat LD<sub>50</sub>. Socker, salt, smör, arsenik, cyanid, vinäger, vin, Clorox, fönsterputs och dussintals andra hushålls- och industrikemikalier är klassade enligt deras toxicitet genom tvångsmatning av 10 råttor med maten eller kemikalien tills hälften av dem dör. Mängden kemikalier eller mat som det krävs för att döda 5 av de 10 råttorna bestämmer LD<sub>50</sub> numret. Varje kemikalie har en giftklass vilken indikeras med LD<sub>50</sub> nummer. Alla kemikalier är giftiga i tillräckligt stora mängder och det finns en hel del olyckliga råttor i vårt samhälle.

Jag vill säga något om blekmedel. Ett antal kritiker hävdar att MMS (klordioxid) är ett gift. Klordioxid, den kemikalie som är MMS, har aldrig använts på hemmamarknaden som blekmedel för rengöring av toaletter. Det är ett industriellt blekmedel vid användning av 4000 högre koncentrerad dos än MMS. Det används aldrig för blekningsändamål i hemmen av människor i den här världen.

En kemikalie som inte har karaktären av blekmedel kan inte kallas blekmedel. Så en klordioxidlösning som är 4000 gånger svagare än blekmedel kan inte kallas blekmedel. Detta är ett faktum som accepteras i domstolar världen över.

Jag hoppas du kommer att ta dig tid att förstå grunderna för klordioxid. Det kan komma en tid när du behöver klordioxid för att rädda ditt eget liv eller en nära anhörig.

*Ärkebiskop Jim Humble*

# Om MMS

Av Andreas Kalcker

När klordioxid (ClO<sub>2</sub>) når magen, som innehåller klorvätesyra (även känd som HCl och saltsyra) äger en reaktion rum mellan de båda substanserna som resulterar i frisättning av en gas som kallas "klordioxid". Denna gas tas lätt upp i vatten (och därmed även av slemhinnor och blodserum) och är ansvarig för "mirakelkurer". Detta är anledningen till att Jim Humble initialt gav det namnet "mirakellösning", eftersom det inte bara fungerar på malaria utan även för många andra sjukdomar.

## Vad vet vi om MMS?

En av de viktigaste aspekterna är att klordioxid är extremt löslig i vatten utan att skapa ytterligare kemiska bindningar. Det innebär att klordioxid löses fullständigt i vatten eftersom dess cellulära struktur är mycket lik den för vatten.

Vi vet att klordioxid är det bästa desinfektionsmedel som människan känner till. Det kan eliminera bakterier, svampar, virus och små parasiter över ett brett pH-område. Det har använts i över 80 år för att desinficera dricksvatten och det har aldrig orsakat ett problem under alla dessa år.

Klordioxid används allmänt inom industrin för desinfektionsändamål. Den används också för pappersblekning, men i extrema halter ~5680 gånger högre. En koncentration som inte har något att göra med den normala intagsdosen.

CDS är endast gasen av MMS-blandningen. CDS är pH-neutral och har många fördelar. CDS brukar inte orsaka irritationer eller biverkningar som MMS och beskrivs fullständigt i Andreas Kalckers första bok "CDS health is Possible".



## Så fungerar MMS/CDS

1. Klordioxid är en gul gas som är löslig i vatten utan att förändra dess struktur.
2. Erhålls genom att blanda natriumklorit och utspädd saltsyra eller citronsyra.
3. Klordioxidgas löst i vatten är en oxidant.
4. Klordioxid är selektiv (särskiljande) för surare pH och patogener.
5. Enligt toxikologiska studier av EPA (US Environmental Protection Agency) lämnar klordioxid inga rester eller ackumuleras i kroppen på lång sikt.
6. I oxidationsprocessen bildas det syre och natriumklorid (vanligt salt).

Den terapeutiska verkan av klordioxid ges av dess selektivitet för pH. Det betyder att denna molekyl dissocierar<sup>1</sup> och frisätter syre när den är i kontakt med en annan syra. Reaktionen blir natriumklorid (salt) och samtidigt frigörs syre som i sin tur oxiderar (förbränner) patogener (bakterier) när surt pH är närvarande, vilket gör oxider ("aska") alkaliska.

Klordioxid frisläpper syre som upplöses i blod. Liksom blod frigör klordioxid syre.

Den terapeutiska effekten bidrar till återhämtningen av många typer av sjukdomar genom att skapa en alkalisk miljö, samtidigt som man eliminerar patogener genom oxidation. Den flercelliga vävnaden<sup>2</sup> har förmågan att avleda denna avgiftning och påverkas inte på samma sätt.

Klordioxid är det näst starkaste desinfektionsmedel efter ozon.

---

<sup>1</sup> Dissociation (kemi) – inom kemien en upplösning av molekyler i mindre beståndsdelar.

<sup>2</sup> Organismer som består av mer än en cell kallas flercelliga.

Klordioxid lämpar sig bättre för terapeutisk användning eftersom det tränger in och tar bort biofilm<sup>3</sup>, vilket ozon inte gör. Den stora fördelen med den terapeutiska användningen av klordioxid är omöjligheten av en bakteriell resistens mot ClO<sub>2</sub> (klordioxid). Även om ozon är starkare när det gäller antiseptiska medel så är det mindre effektivt för terapeutiska tillämpningar.

Klordioxid är en selektiv oxidant, och till skillnad från andra ämnen reagerar det inte med de flesta komponenterna i levande vävnad. Klordioxid i sig reagerar snabbt mot fenoler<sup>4</sup> essentiella för bakteriellt liv.

## Fakta och siffror

1. Klordioxid är inte ett toxin som ackumuleras i kroppen. Till skillnad från andra ämnen upplöses det direkt när det reagerar med patogener.
2. Under 100 år av användning finns det bara fem dokumenterade fall av förgiftning, och alla av dem överlevde trots att de tog doser som var hundratals gånger högre än rekommenderad dos.
3. Om du andas in luft som innehåller en stor mängd av klordioxidgas kan du uppleva irritation i hals, näsa och lungor.
4. Om det är alltför koncentrerat uppstår ögonirritation som är reversibel.

---

<sup>3</sup> En biofilm är ett aggregat eller kluster av mikroorganismer, till exempel bakterier, som gemensamt bildar en skyddande yta med vars hjälp de vidhäftar.

<sup>4</sup> Fenoler (efter fenol) är kolföreningar med en eller flera hydroxigrupper bunden till en eller flera bensenringar.

5. På grund av de uppgifter som hittills erhållits, och dess användning under 100 år, kan vi konstatera att klordioxid inte är cancerframkallande.
6. Det finns inga bevis för skadlig toxicitet när det gäller reproduktion (återskapande).

## Hittills fastställt i den vetenskapliga litteraturen:

- Det finns inga endokrinologiska<sup>5</sup> effekter på människor i samband med intag av klordioxid.
- Det finns inte några negativa viktändringseffekter på människor i samband med intag av klordioxid.
- Det finns inga lymfatiska<sup>6</sup> immunologiska effekter på människor i samband med intag av klordioxid.
- Det finns inga neurologiska effekter på människor i samband med intag av klordioxid.
- Det finns inte några effekter på fortplantningssystemen hos människor i samband med intag av klordioxid.
- Det finns inte några effekter där cancer kan kopplas till människor och intag av klordioxid.
- Det finns inte några mutagena<sup>7</sup> effekter på människor i samband med intag av klordioxid.
- Det finns inga kända effekter av klordioxid eller klorit ackumulering i människor.
- Det finns inte några dokumenterade dödsfall genom förgiftning på grund av intag av klordioxid i den vetenskapliga litteraturen.

Källor för ovanstående punkter finns i bifogade vetenskapliga artiklar längre fram i boken.

---

<sup>5</sup> Endokrinologi är den medicinska disciplin som intresserar sig för kroppens tillverkning, insöndrande och påverkan av hormoner i kroppen.

<sup>6</sup> Det lymfatiska systemet eller lymfsystemet är ett system hos människan och andra däggdjur, bestående av lymfan, lymfkärlen och ett flertal organ.

<sup>7</sup> En mutagen är en företeelse, till exempel ett kemiskt ämne, som orsakar mutationer hos en organism, det vill säga förändrar den genetiska informationen (DNA) i organismen.

# Gör eget MMS

Det är enkelt att göra MMS. Det behövs två ingredienser.

- Natriumklorit 80%
- Destillerat/rent vatten

Genesis II har videor som visar hur du går till väga.

[Se videor »](#)

På FramStegets hemsida finns kalkylator för att beräkna hur mycket du ska ha i av varje.

[Beräkna mått »](#)



Natriumklorit

# CDS - Klordioxidlösning

Av Kerri Rivera

Klordioxidlösning (CDS) är ett förfarande för framställning och användning av klordioxid. För att framställa CDS behövs MMS och aktivator. Mer om detta längre fram i boken.

## CDS bakgrund

Dr Andreas Kalcker blev kontaktad av en bonde som var frustrerad över nyfödda kalvars hälsoproblem. Kalvarna led av infektioner, diarré, öronproblem, cystor, koccidios, bovin respiratorisk sjukdom etc. Uppfödarens årliga läkemedelskostnad var cirka 28,000 euro, exklusive kostnaderna för foder. Bonden hade hört talas om underverket MMS hos människor och undrade om det kunde hjälpa djuren också.

Andreas tänkte "Visst! Varför inte?" Men snabbt fick han veta att boskap skiljer sig mycket från människor när det gäller matsmältningssystem. Nötkreatur smälter genom jäsning, som CD stör, så han var tvungen att hitta ett sätt att kringgå djurens matsmältningssystem och gå direkt till deras blod. Men den idén hade ett annat stort problem. PH-värdet i vanlig CD är alltför surt och är därför inte förenligt med kalvarnas blod. Injektion med utspädd CD orsakar stor smärta och kan leda till skador på nerver. Det måste finnas ett annat sätt.

Efter mycket eftertanke och forskning kom Andreas fram med destillationsprocessen för att extrahera klordioxid, den viktigaste ingrediensen från CD-blandning så det inte innehåller någon natriumklorit eller sur aktivator. Han kallade den erhållna vätskan för klordioxidlösning (vanligen förkortat CDS).

*OBS: CDS kan fortfarande innehålla spårmängder av natriumklorit och sur aktivator (citronsyra) som används för att producera det, men oftast inte tillräckligt för att vara ett problem.*

*Denna nya CDS-lösning sprutades in i 800 nötkreatur med mycket*

*positiva resultat. Djurhälsan förbättrades och bondens veterinärräkningar sjönk som en sten.*

I ett fall kontaktade bonden Andreas angående en särskilt sjuk ko. Andreas rådde honom att ge en dos, men tydligen missförstodde bonden instruktionerna och gav kon 10 gånger den rekommenderade mängden. Resultatet? Kon var lite "hög" med öron och svans som stod upp, men blev sedan frisk utan några biverkningar av den oavsiktligt höga dosen.

CDS löser problemet som vissa människor har med känslighet för citronsyra, liksom smaken av CD. Att inte ha de ursprungliga kemikalierna (natriumklorit / citronsyra eller salt-syra) i CDS gör en stor skillnad för vissa. En annan fördel med CDS är en drastisk minskning av Herxheimer reaktioner<sup>8</sup>.

Andreas Kalcker, mannen som tog fram CDS.

[Besök Andreas »](#)



---

<sup>8</sup> När kroppen avgiftas för snabbt. Gifter frigörs mer än kroppen kan göra sig av med. Symptom som t ex illamående och huvudvärk.

## Framställa vs. köpa CDS

Många människor är lite oroade över att framställa CDS eftersom det innebär en destillationsprocess där man producerar klordioxidgas och sedan överför det till vatten. När Andreas Kalcker kom på att göra CDS involverade det två behållare, en slang, värme och bra ventilation. Det finns fortfarande många videor på YouTube som förklarar den ursprungliga processen. Emellertid finns det nu ett mycket bättre, enklare och säkrare sätt att producera CDS hemma. Den nya processen innebär inte någon värme eller slangar.

Det finns några försäljare online som säljer CDS, men priset är ganska högt. Du kan göra din egen CDS istället. Det är enkelt att lära sig processen och utrustningen som krävs är lättillgänglig. Dessutom kommer du få en bättre förståelse för klordioxid om du gör din egen CDS.

CDS kan du enkelt göra själv.  
Se längre fram i boken.



## Några viktiga CDS-punkter

När det gäller CDS så handlar det om koncentrationen av klordioxid i vatten. Detta mäts i miljondelar - förkortat ppm.

När du köper eller gör din egen CDS är målet CDS med en koncentrationsstyrka på 3,000 ppm. Flaskan till förvaring bör helst vara av glas och förvaras i kylskåp. Du använder aldrig denna koncentrerade lösning direkt, den måste spädas.

När man säger till exempel ”använd 10 ml av CDS” ska du blanda 10 ml 3,000 ppm CDS med angiven mängd vatten och använda den utspädda blandningen för det angivna ändamålet.

Det bör också noteras att koncentrationsstyrkan reduceras varje gång du öppnar CDS-flaskan då klordioxidgas avdunstar. När du öppnar källbehållaren så försvinner en del av klordioxidgasen. Så styrkan i en halvfull CD-flaska kan vara betydligt mindre än vad du började med när flaskan var full.

För att avsevärt minska avdunstning av klordioxidgas bör CDS-flaskan förvaras i kylskåp. Detta stabiliserar och reducerar mängden utströmmande CD-gas ur lösningen. Men oavsett temperaturen kommer en del gas alltid att fly och minska koncentrationen varje gång flaskan öppnas. En flaska med smal hals bidrar till att upprätthålla integriteten av CDS under längre perioder.

Det är bättre att lagra koncentrerad CDS i exempelvis 300 ml flaskor än att förvara den i en större literflaska.

# Att framställa CDS

Låt oss först gå igenom de grundläggande principerna för framställning av CDS. Därefter går vi in på detaljer.

Vi börjar med två behållare (båda gjorda av glas). En behållare är större och har ett lock som kan tillslutas väl. Locket ska vara av glas eller plast. Metall oxiderar. Den andra behållaren är mindre utan lock. Den relativa storleken på varje behållare är sådan att den mindre behållaren passar bekvämt inuti den större.

Konserveringsburk med gummitätning.  
Mindre glas eller behållare.





Fyll det mindre glaset med 12 ml MMS och 12 ml aktivator.



Placera det mindre glaset i den större behållaren. Stäng locket och placera mörkt 12–24 timmar i rumstemperatur.

Den stora behållaren fylls med rumstempererat destillerat/renat vatten. Vattennivån måste vara tillräckligt låg för att inte rinna över in i den mindre behållaren.

### Gör CDS

1. Börja med att hälla 240 ml destillerat/rent vatten i den större glasbehållaren<sup>9</sup>. Vattnet bör vara omkring rumstemperatur.
2. Mät upp 12 ml av MMS och häll i det mindre glaset.
3. Mät upp 12 ml av 10% HCl (saltsyra) eller 50% citronsyralösning och häll i det mindre glaset. Om du gjorde allt rätt ska CD-lösningen få en mörkt bärnstensfärgad/brun nyans inom cirka en minut.
4. Placera det mindre glaset i den större behållaren.
5. Fäst/skruva omedelbart på locket till den stora behållaren. Var försiktig så att inte blandningen i det mindre glaset spills över i vattnet. Se till att locket är ordentligt monterat för att undvika läckor. Om det luktar klordioxid (utöver det lilla som flyr när du sätter på locket) behövs det bättre tätning mellan glasbehållare och lock.
6. Lägg märke till att vattnet börjar få en ljusgul färg allt eftersom. Det kan bildas bubblor i glaset. Det är normalt för trycket att förändras under den kemiska reaktionen. Man har funnit att citronsyra alstrar vakuum och HCl kan först producera ett tryck och sedan ett vakuum.
7. Ställ kittet på en mörk plats eller täck över med en handduk för att minska exponering för ljus. Det behöver inte vara en kolsvart plats, men det ska definitivt inte förvaras i direkt solljus. Kolla gärna från tid till tid och se hur färgerna förändras. Naturligtvis ska du hålla

---

<sup>9</sup> Renat vatten fungerar också om du inte har tillgång till destillerat.

detta kit utom räckhåll för barn, djur eller något som kan störa det.

8. När färgen i det mindre glaset överensstämmer någorlunda med det omgivande vattnet är den kemiska reaktionen fullständig. Det skadar inte att vänta lite längre men inget mer kommer att hända. Detta tar vanligtvis 12–24 timmar beroende på rumstemperatur och styrkan hos den använda syran.
9. Ha lagringsflaskor rena och redo för CDS-lösningen.
10. Innan du öppnar satsen se till att din arbetsplats är väl ventilerad.
11. Öppna långsamt behållaren och var noga med att inte CD-lösningen i den mindre behållaren blandas med den nyligen gjorda CDS:en. Om kemikalierna blandas måste du börja om igen, så var försiktig! Det kommer troligen lukta klordioxid i rummet när du öppnar behållaren. Detta är normalt därav behovet av god ventilation.
12. Ta försiktigt bort det mindre glaset. CD-lösningen i det mindre glaset kan du använda för luftrening. Förvara i en separat, tät och uppmärkt glasbehållare. Om du inte ska använda CD-lösningen spolar du ner det i toaletten. Skölj rent glaset.
13. Håll CDS i lagringsflaskor.
14. Se till att flaskan/flaskorna med CDS sluter tätt och placera i kylskåp.

*OBS! 10% HCl (saltsyra) är den rekommenderade aktivatorn när du gör CDS. Du kan också använda 4% HCl, men reaktionstiden kommer att förlängas. Det går även att använda 50% citronsyralösning. Det kan ta så mycket som en hel dag innan färgen på CD-lösning och vattnet matchar.*

Färdig CDS



## Mät styrkan på CDS

CDS fungerar eftersom den innehåller klordioxid (ClO<sub>2</sub>). ClO<sub>2</sub> produceras när en 22,4% lösning av natriumklorit (NaClO<sub>2</sub>) aktiveras med en syra, vanligtvis 10% eller 4% HCl (saltsyra) eller 50% citronsyralösning för CDS.

Ibland kan det vara användbart att mäta mängden ClO<sub>2</sub> i lösningen. Det kan vara nödvändigt att känna till mängden klordioxid om du inte får förväntade resultat. Det kan vara problem med ingredienser eller processen, och att känna till mängden ClO<sub>2</sub> i lösningen kan vara till hjälp med att bestämma vad som kan vara fel.

Mängden ClO<sub>2</sub> i en lösning mäts i miljondelar (ppm). Det är nödvändigt att specificera volymen av lösningen när man talar om ClO<sub>2</sub> ppm, eftersom ppm varierar beroende på utspädning av lösningen.

Om du använder CDS förutsätts det att du förbereder den för 3,000 ppm. Om du använder CDS kom ihåg att den relativa styrkan av en milliliter CDS är cirka 60% av en droppe CD (MMS).

Om ingredienserna är av god kvalitet finns det oftast ingen anledning att känna till eller mäta koncentrationen av ClO<sub>2</sub>.

Mätning av koncentrationen av ClO<sub>2</sub> kan lätt göras hemma. Det du behöver köpa är testremсор för klordioxid tillverkade av Lamotte eller andra. *Lamotte Insta-Test® High-Range Test Strips, 0 to 500 ppm* (kod #3002). Behållarens etikett har ett diagram som visar sju färger där varje färg indikerar en ClO<sub>2</sub> koncentration i ppm.

Anvisningar för hur man använder Lamotte testremсор är tryckt på sidan av behållaren och måste följas för att få en korrekt ClO<sub>2</sub> läsning.

Siffrorna under var och en av de sju färgerna representerar 0, 10, 25, 50, 100, 250 och 500 ppm. Många som använder testremorna tycker att 50 ppm är det bästa att använda för färgmatchning, eftersom de lättare kan se skillnaden i färg under och över den färgen än de andra.

Om CDS-lösningen du vill mäta misstänks vara 3,000 ppm, hur mäter man det om testremornas högsta ClO<sub>2</sub> koncentration är 500 ppm? Det är alltid nödvändigt att ange volymen av lösningen när man talar om ClO<sub>2</sub> ppm, eftersom ppm kommer att variera beroende på utspädning av lösningen.

För att utläsa 3,000 ppm med en testremsa, och få det att matcha 50 ppm på behållaren, måste vi späda ut ett litet urval av CDS-lösningen.

1. Häll 60 ml destillerat vatten i ett litet glas och tillför sedan 1 ml av CDS-lösningen.
2. Rör om ordentligt för att jämnt fördela ClO<sub>2</sub> provet i vattnet.
3. Ta sedan en av testremorna. Var noga med att inte röra dynan av kemikalier på änden av remsan. Doppa remsan i lösningen under två sekunder. Håll bandet på ett ställe i lösningen och flytta inte runt under tvåsekundersperioden.
4. Ta bort remsan från CDS-lösningen med dynan uppåt och vänta tio sekunder. Jämför färgen på testremsan med färgkartan på sidan av behållaren.

Om stamlösningen är 3,000 ppm kommer färgen på testremsan att matcha 50 ppm färgen på behållaren. Multiplicera 50 gånger 60 (mängden utspädning) och du får 3,000 ppm.

Om färgen på testremsan inte överensstämmer med 50 ppm färg på behållaren försök att uppskatta ppm tal mellan färger



och multiplicera den siffran med 60 för att få ClO<sub>2</sub> koncentrationen.

*Tips: Du kan klippa banden på längden för att få 100 remsor i stället för 50. Var säker på att inte röra bandet med fingrarna eller så kan dina avläsningar bli missvisande. Det är också viktigt att hålla behållaren tätt försluten för att hålla borta fukt som kan påverka avläsningarna.*

### Insta-TEST® Chlorine Dioxide



# Späda ut HCl-koncentration

Protokoll för CDS använder ofta två olika koncentrationer av saltsyra (HCl): 10% och 4%. Vissa leverantörer säljer båda koncentrationerna, medan andra bara en. I Sverige är det lättast att få tag på saltsyra 30%. Du kan också hitta saltsyra med en annan koncentration och vill späda ut det till 4% eller 10%. Matematiken för att bestämma hur mycket du ska späda din grundlösning är ganska enkel.

Låt oss säga att du har 10% HCl och vill göra en liter 4% HCl. Du behöver då 400 ml 10% HCl och 600 ml vatten för att göra en liter 4% HCl.

På FramStegets hemsida finns kalkylator för beräkning:

<http://www.framsteget.net/mms-solution>

## Manuell beräkning för utspädning av saltsyra (HCl)

### Beräkning 1:

*Önskad volym (ml) x önskad koncentration (10%) = Temporärt värde*

### Beräkning 2:

*Temporärt värde / Ursprunglig koncentration (30%) = Ursprunglig mängd*

### Beräkning 3:

*Önskad volym (ml) - Ursprunglig mängd = Mängd vatten att tillsätta*

# Från MMS till CDS

## Blandning

12 ml MMS + 12 ml aktivator till 240 ml destillerat/renat vatten.

## Aktivator kan vara

- Citronsyra 50%.
- Saltsyra (HCL) 10% eller 4%. Saltsyra 30% finns hos diverse handlare.

Saltsyra som aktivator är att föredra. 10% eller 4% saltsyra används för CDS. 10% saltsyra påskyndar processen.

## Metoder

”Slangmetoden”: När MMS och vatten/CLO<sub>2</sub> har samma färg är CDS klar ([se video](#)).

”Glas i burk”: För metod med glas i burk 12–24 timmar. Innan upphällning i mindre behållare låt gärna stå 2 timmar i kylskåp.

Klordioxidhalt (Clo<sub>2</sub>) kan mätas med mätsticka för klordioxid. Värde för CDS bör vara omkring 3,000 ppm.

## Förvaring

CDS ska förvaras svalt (under 11 grader Celsius) och mörkt för att behålla styrka. Förvara gärna CDS i tät glasflaska.

**6 ml CDS motsvarar 3 droppar aktiverad MMS.**

# Att ta CDS (standardprotokoll)

## Alternativ 1

1. Tillsätt 1 dl destillerat/rent vatten i ett glas
2. Häll i 6 ml CDS i glaset
3. Drick

## Alternativ 2

1. Fyll en flaska med 8 dl destillerat/rent vatten
2. Häll i 48 ml CDS i flaskan<sup>10</sup>
3. Drick 1 dl per timme

En dos varje timme under 8 timmar under en period av 21 dagar. Detta protokoll används för att rena och avgifta kroppen. Undvik kaffe, te, mjölk och c-vitamin en timme före och en timme efter du har tagit CDS eftersom det neutraliserar effekten. För specifika problem och sjukdomar används särskilda protokoll. Dessa protokoll finner du på bland annat Jim Humbles hemsida.

*När du börjar ta CDS kan du starta med en mindre dos de första dagarna. Detta för att undvika eventuellt illamående eller diarré. Illamående eller diarré betyder inte att MMS/CDS är farligt. Dessa biverkningar tyder på att kroppen innehåller mycket gifter och patogener, och därför behöver man ta det lugnare till att börja med.*

---

<sup>10</sup> Låt gärna flaskan stå i kylan. Om du har med den förvara den mörkt.

Vetenskapliga artiklar

Klordioxid

# 4. CHLORINE DIOXIDE

---

Since the beginning of the twentieth century, when it was first used at a spa in Ostend, Belgium, chlorine dioxide has been known as a powerful disinfectant of water. During the 1950s, it was introduced more generally as a drinking water disinfectant since it provided less organoleptic hindering than chlorine. Approximately 700 to 900 public water systems use chlorine dioxide to treat potable water (Hoehn, 1992). Today, the major uses of chlorine dioxide are:

- CT disinfection credit;
- Preoxidant to control tastes and odor;
- Control of iron and manganese; and
- Control of hydrogen sulfide and phenolic compounds.

## 4.1 Chlorine Dioxide Chemistry

### 4.1.1 Oxidation Potential

The metabolism of microorganisms and consequently their ability to survive and propagate are influenced by the oxidation reduction potential (ORP) of the medium in which it lives (USEPA, 1996).

Chlorine dioxide ( $\text{ClO}_2$ ) is a neutral compound of chlorine in the +IV oxidation state. It disinfects by oxidation; however, it does not chlorinate. It is a relatively small, volatile, and highly energetic molecule, and a free radical even while in dilute aqueous solutions. At high concentrations, it reacts violently with reducing agents. However, it is stable in dilute solution in a closed container in the absence of light (AWWA, 1990). Chlorine dioxide functions as a highly selective oxidant due to its unique, one-electron transfer mechanism where it is reduced to chlorite ( $\text{ClO}_2^-$ ) (Hoehn et al., 1996). The pKa for the chlorite ion, chlorous acid equilibrium, is extremely low at pH 1.8. This is remarkably different from the hypochlorous acid/hypochlorite base ion pair equilibrium found near neutrality, and indicates the chlorite ion will exist as the dominant species in drinking water. The oxidation reduction of some key reactions are (CRC, 1990):



Other important half reactions are:



In drinking water, chlorite ( $\text{ClO}_2^-$ ) is the predominant reaction endproduct, with approximately 50 to 70 percent of the chlorine dioxide converted to chlorite and 30 percent to chlorate ( $\text{ClO}_3^-$ ) and chloride ( $\text{Cl}^-$ ) (Werdehoff and Singer, 1987).

## 4.2 Generation

### 4.2.1 Introduction

One of the most important physical properties of chlorine dioxide is its high solubility in water, particularly in chilled water. In contrast to the hydrolysis of chlorine gas in water, chlorine dioxide in water does not hydrolyze to any appreciable extent but remains in solution as a dissolved gas (Aieta and Berg, 1986). It is approximately 10 times more soluble than chlorine (above  $11^\circ\text{C}$ ), while it is extremely volatile and can be easily removed from dilute aqueous solutions with minimal aeration or recarbonation with carbon dioxide (e.g. softening plants). Above  $11$  to  $12^\circ\text{C}$ , the free radical is found in gaseous form. This characteristic may affect chlorine dioxide's effectiveness when batching solutions and plumbing appropriate injection points. Other concerns are the increased difficulty in analyzing for specific compounds in the presence of many interfering compounds/residual longevity and volatility of gaseous compounds. In the gaseous form, the free radicals also react slowly with water. The reaction rate is 7 to 10 million times slower than that of the hydrolysis rate for chlorine gas (Gates, 1989).

Chlorine dioxide cannot be compressed or stored commercially as a gas because it is explosive under pressure. Therefore, it is never shipped. Chlorine dioxide is considered explosive at higher concentrations which exceed 10 percent by volume in air, and its ignition temperature is about  $130^\circ\text{C}$  ( $266^\circ\text{F}$ ) at partial pressures (National Safety Council Data Sheet 525 –  $\text{ClO}_2$ , 1967). Strong aqueous solutions of chlorine dioxide will release gaseous chlorine dioxide into a closed atmosphere above the solution at levels that may exceed critical concentrations. Some newer generators produce a continuous supply of dilute gaseous chlorine dioxide in the range of 100 to 300 mm-Hg (abs) rather than in an aqueous solution (National Safety Council, 1997). For potable water treatment processes, aqueous solutions between 0.1 and 0.5 percent are common from a number of current generation technologies.

Most commercial generators use sodium chlorite ( $\text{NaClO}_2$ ) as the common precursor feedstock chemical to generate chlorine dioxide for drinking water application. Recently, production of chlorine dioxide from sodium chlorate ( $\text{NaClO}_3$ ) has been introduced as a generation method where in  $\text{NaClO}_3$  is reduced by a mixture of concentrated hydrogen peroxide ( $\text{H}_2\text{O}_2$ ) and concentrated sulfuric acid ( $\text{H}_2\text{SO}_4$ ). Chlorate-based systems have traditionally been used in pulp and paper applications, but have recently been tested full-scale at two U.S. municipal water treatment plants. This is an emerging technology in the drinking water field and is not discussed in this guidance manual.

## 4.2.2 Chlorine Dioxide Purity

Chlorine dioxide generators are operated to obtain the maximum production (yield) of chlorine dioxide, while minimizing free chlorine or other residual oxidant formation. The specified yield for chlorine dioxide generators is typically greater than 95 percent. In addition, the measurable excess chlorine should be less than 2 percent by weight in the generator effluent. Generator yield is defined as (Gordon et al., 1990):

$$\text{Yield} = \frac{[\text{ClO}_2]}{[\text{ClO}_2] + [\text{ClO}_2^-] + \left(\frac{67.45}{83.45}\right)[\text{ClO}_3^-]} \times 100$$

Where:  $[\text{ClO}_2]$  = Chlorine dioxide concentration, mg/L.

$[\text{ClO}_2^-]$  = Chlorite concentration, mg/L.

$[\text{ClO}_3^-]$  = Chlorate concentration, mg/L.

$\left(\frac{67.45}{83.45}\right)$  = Molecular weight ratio of  $\text{ClO}_2^-$  to  $\text{ClO}_3^-$ .

Since any chlorite ion fed to the generator may result in the formation of  $\text{ClO}_2$ ,  $\text{ClO}_2^-$ , or  $\text{ClO}_3^-$ , the purity of the resultant mixture can be calculated using the concentrations of each of the species from appropriate analytical measurements. The determination of purity requires neither flow measurement, mass recoveries, nor manufacturer-based methods to determine production “yield,” “theoretical yield,” “efficiency,” or conversion for any precursor feedstock. This approach does not require flow measurements that can introduce up to 5 percent error in the calculations.

Utilities that use chlorine dioxide should measure excess chlorine (as FAC) in the generator effluent in addition to the  $\text{ClO}_2^-$  related species. FAC may appear as false  $\text{ClO}_2$  residuals for CT purposes, or result in the formation of chlorinated DBPs if high, relative to the  $\text{ClO}_2$  level in the generated mixture. Excess chlorine is defined as:

$$\text{Excess Cl}_2 = \frac{[\text{Cl}_2]}{[\text{ClO}_2] + [\text{ClO}_2^-] + \left(\frac{67.45}{83.45}\right)[\text{ClO}_3^-] \times \frac{70.91}{2 \times 67.45}} \times 100$$

Where:  $\frac{70.91}{(2 \times 67.45)}$  = stoichiometric and molecular weight ratio of  $\text{Cl}_2$  to  $\text{ClO}_2^-$ .

The following represents a summarily simpler equation that substantially resolves the problems of different equipment-specific calibration methods, chlorine-contaminated  $\text{ClO}_2$ , or low efficiency conversion of either chlorite- or chlorate-based precursor material.



$$\text{Purity} = \frac{[\text{ClO}_2]}{[\text{ClO}_2] + [\text{FAC}] + [\text{ClO}_2^-] + [\text{ClO}_3^-]} \times 100$$

This practical (weight-based) calculation permits a variety of approved analytical methods (discussed in section 4.6) to be used to assess generator performance on unbiased scientific principles, rather than non-standardized manufacturer specifications.

### 4.2.3 Methods of Generating Chlorine Dioxide

For potable water application, chlorine dioxide is generated from sodium chlorite solutions. The principal generation reactions that occur in the majority of generators have been known for a long time. Chlorine dioxide can be formed by sodium chlorite reacting with gaseous chlorine ( $\text{Cl}_{2(\text{g})}$ ), hypochlorous acid ( $\text{HOCl}$ ), or hydrochloric acid ( $\text{HCl}$ ). The reactions are:

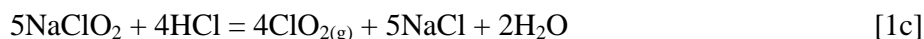
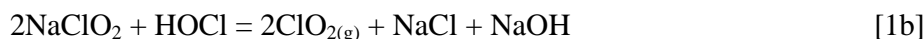

Reactions [1a], [1b], and [1c] explain how generators can differ even though the same feedstock chemicals are used, and why some should be pH controlled and others are not so dependent on low pH. In most commercial generators, there may be more than one reaction taking place. For example, the formation and action of hypochlorous acid as an intermediate (formed in aqueous solutions of chlorine) often obscures the “overall” reaction for chlorine dioxide production.

Table 4-1 provides information on some types of available commercial generators. Conventional systems react sodium chlorite with either acid, aqueous chlorine, or gaseous chlorine. Emergent technologies identified in Table 4-1 include electrochemical systems, a solid chlorite inert matrix (flow-through gaseous chlorine) and a chlorate-based emerging technology that uses concentrated hydrogen peroxide and sulfuric acid.

**Table 4-1. Commercial Chlorine Dioxide Generators**

GENERATOR TYPE	MAIN REACTIONS Reactants, byproducts, key reactions, and chemistry notes	SPECIAL ATTRIBUTES
ACID-CHLORITE: (Direct Acid System)	$4\text{HCl} + 5\text{NaClO}_2 \rightarrow 4\text{ClO}_{2(\text{aq})} + \text{ClO}_3^-$ <ul style="list-style-type: none"> <li>• Low pH</li> <li>• <math>\text{ClO}_3^-</math> possible</li> <li>• Slow reaction rates</li> </ul>	Chemical feed pump interlocks required. Production limit ~ 25-30 lb/day. Maximum yield at ~80% efficiency.
AQUEOUS CHLORINE- CHLORITE: ( $\text{Cl}_2$ gas ejectors with chemical pumps for liquids or booster pump for ejector water).	$\text{Cl}_2 + \text{H}_2\text{O} \rightarrow [\text{HOCl} / \text{HCl}]$  $[\text{HOCl}/\text{HCl}] + \text{NaClO}_2 \rightarrow \text{ClO}_{2(\text{g})} + \text{H}/\text{OCl} + \text{NaOH} + \text{ClO}_3^-$ <ul style="list-style-type: none"> <li>• Low pH</li> <li>• <math>\text{ClO}_3^-</math> possible</li> <li>• Relatively slow reaction rates</li> </ul>	Excess $\text{Cl}_2$ or acid to neutralize NaOH. Production rates limited to ~ 1000 lb/day. High conversion but yield only 80-92% More corrosive effluent due to low pH (~2.8-3.5). Three chemical systems pump HCl, hypochlorite, chlorite, and dilution water to reaction chamber.
RECYCLED AQUEOUS CHLORINE OR "FRENCH LOOP" <sup>TM</sup> (Saturated $\text{Cl}_2$ solution via a recycling loop prior to mixing with chlorite solution.)	$2\text{HOCl} + 2\text{NaClO}_2 \rightarrow 2\text{ClO}_2 + \text{Cl}_2 + 2\text{NaOH}$ <ul style="list-style-type: none"> <li>• Excess <math>\text{Cl}_2</math> or HCl needed due to NaOH formed.</li> </ul>	Concentration of ~3 g/L required for maximum efficiency. Production rate limited to ~ 1000 lb/day. Yield of 92-98% with ~10% excess $\text{Cl}_2$ reported. Highly corrosive to pumps; draw-down calibration needed. Maturation tank required after mixing.
GASEOUS CHLORINE- CHLORITE (Gaseous $\text{Cl}_2$ and 25% solution of sodium chlorite; pulled by ejector into the reaction column.)	$\text{Cl}_{2(\text{g})} + \text{NaClO}_{2(\text{aq})} \rightarrow \text{ClO}_{2(\text{aq})}$ <ul style="list-style-type: none"> <li>• Neutral pH</li> <li>• Rapid reaction</li> <li>• Potential scaling in reactor under vacuum due to hardness of feedstock.</li> </ul>	Production rates 5-120,000 lb/day. Ejector-based, with no pumps. Motive water is dilution water. Near neutral pH effluent. No excess $\text{Cl}_2$ . Turndown rated at 5-10X with yield of 95-99%. Less than 2% excess $\text{Cl}_2$ . Highly calibrated flow meters with min. line pressure ~ 40 psig needed.
GASEOUS CHLORINE- SOLIDS CHLORITE MATRIX (Humidified $\text{Cl}_2$ gas is pulled or pumped through a stable matrix containing solid sodium chlorite.)	$\text{Cl}_{2(\text{g})} + \text{NaClO}_{2(\text{s})} \rightarrow \text{ClO}_{2(\text{g})} + \text{NaCl}$ <ul style="list-style-type: none"> <li>• Rapid reaction rate</li> <li>• New technology</li> </ul>	$\text{Cl}_2$ gas diluted with $\text{N}_2$ or filtered air to produce ~8% gaseous $\text{ClO}_2$ stream. Infinite turndown is possible with >99% yield. Maximum rate to ~1200 lb/day per column; ganged to >10,000 lb/day.
ELECTROCHEMICAL (Continuous generation of $\text{ClO}_2$ from 25% chlorite solution recycled through electrolyte cell)	$\text{NaClO}_{2(\text{aq})} \rightarrow \text{ClO}_{2(\text{aq})} + \text{e}^-$ <ul style="list-style-type: none"> <li>• New technology</li> </ul>	Counter-current chilled water stream accepts gaseous $\text{ClO}_2$ from production cell after it diffuses across the gas permeable membrane. Small one-pass system requires precise flow for power requirements (Coulombs law).
ACID/PEROXIDE/CHLORIDE	$2\text{NaClO}_3 + \text{H}_2\text{O}_2 + \text{H}_2\text{SO}_4 \rightarrow 2\text{ClO}_2 + \text{O}_2 + \text{NaSO}_4 + \text{H}_2\text{O}$	Uses concentrated $\text{H}_2\text{O}_2$ and $\text{H}_2\text{SO}_4$ . Downscaled version; Foam binding; Low pH.

Source: Adapted from Gates, 1998.

#### 4.1.1.1 Commercial Generators

The conventional chlorine-chlorite solution method generates chlorine dioxide in a two-step process. First, chlorine gas is reacted with water to form hypochlorous acid and hydrochloric acid. These

acids then react with sodium chlorite to form chlorine dioxide. The ratio of sodium chlorite to hypochlorous acid should be carefully controlled. Insufficient chlorine feed will result in a large amount of unreacted chlorite. Excess chlorine feed may result in the formation of chlorate ion, which is an oxidation product of chlorine dioxide and not currently regulated.

**Acid-Chlorite Solution** - Chlorine dioxide can be generated in direct-acidification generators by acidification of sodium chlorite solution. Several stoichiometric reactions have been reported for such processes (Gordon et al., 1972). When chlorine dioxide is generated in this way, hydrochloric acid is generally preferred (Reaction [1c]).

**Aqueous Chlorine-Chlorite Solution** - Chlorite ion (from dissolved sodium chlorite) will react with hydrochloric acid and hypochlorous acid to form chlorine dioxide in these systems, commonly referred to as conventional systems (Reaction [1b]):

Figure 4-1 shows a typical chlorine dioxide generator using aqueous chlorine-chlorite solution (Demers and Renner, 1992).

If chlorine gas and chlorite ion are allowed to react under ideal conditions (not usually formed in aqueous chlorine type systems), the resulting pH of the effluent may be close to 7. To fully utilize sodium chlorite solution, the more expensive of the two ingredients, excess chlorine is often used. This approach lowers the pH and drives the reaction further toward completion. The reaction is faster than the acid-chlorite solution method, but much slower than the other commercial methods described in the following discussion.

**Recycled Aqueous Chlorine or “French Loop”™** - In this aqueous chlorine design, shown in Figure 4-2, chlorine gas is injected into a continuously circulating water loop. This eliminates the need for a great excess of Cl<sub>2</sub> gas to be fed to the generator since the molecular chlorine will dissolve in the feed water, and thus maintain a low pH level of the feed water. Loop-based generators keep chlorine at or above saturation levels. The low pH condition results in high yields of chlorine dioxide (greater than 95 percent at design production rate) (Thompson, 1989). Chlorine in the generator effluent may react with chlorine dioxide to form chlorate if allowed to stand in batch storage too long. The “French Loop” type of generator is more difficult to operate due to system start-up and control of sodium chlorite feed rate (meter pump), chlorine feed rate (rotameter), and the recirculating loop (pump). Newer designs incorporate a second batching tank for continuous aqueous chlorine storage, thus removing many of these startup or recycling difficulties.

**Gaseous Chlorine-Chlorite Solution** - Sodium chlorite solution can be “vaporized” and reacted under vacuum with molecular gaseous chlorine. This process uses undiluted reactants and is much more rapid than chlorine solution:chlorite solution methods (Pitochelli, 1995). Production rates are more easily scaled up, and some installed systems have reported producing more than 60,000 pounds per day.

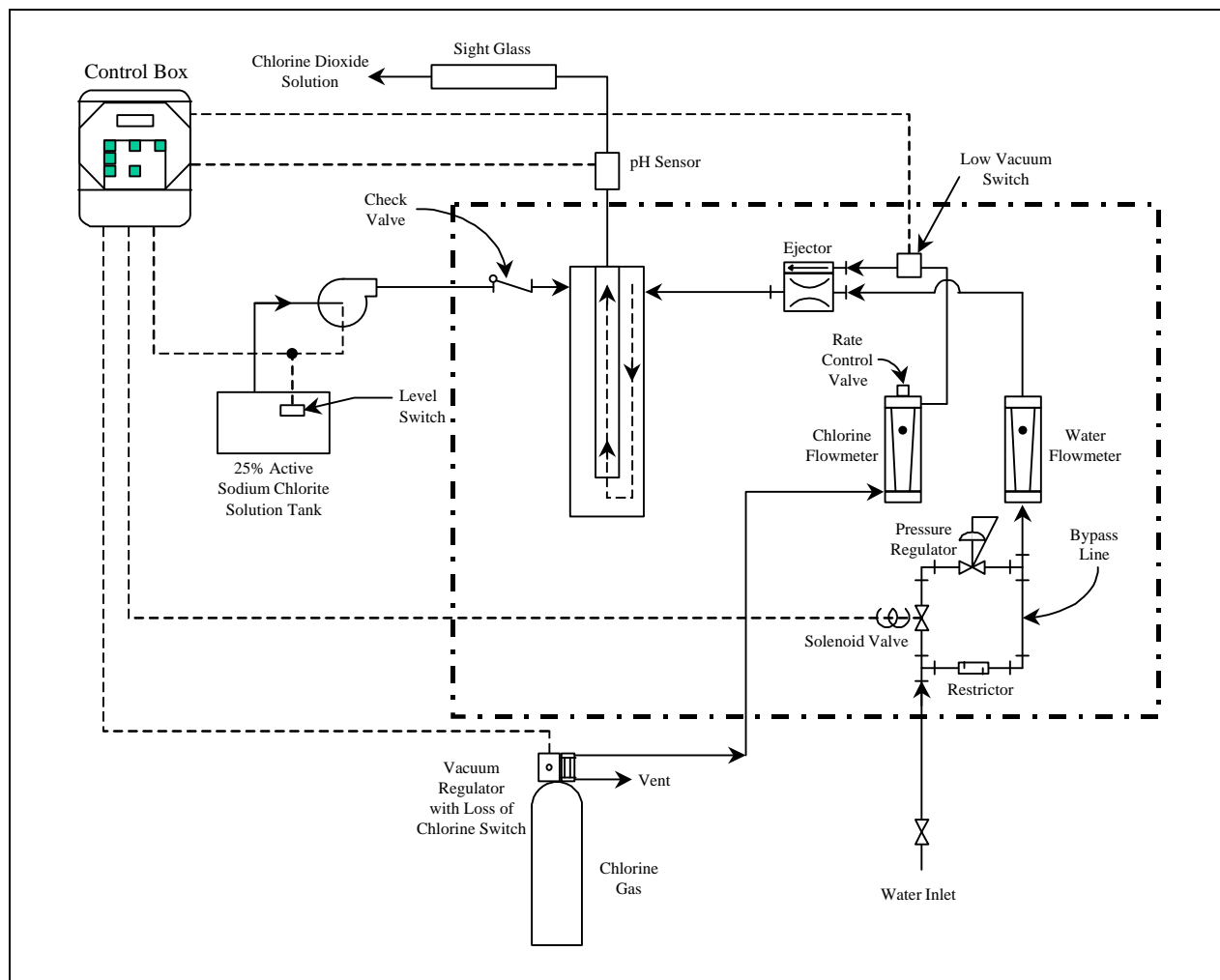

Source: Demers and Renner, 1992.

**Figure 4-1. Conventional Chlorine Dioxide Generator When Using Chlorine-Chlorite Method**

The acid-sodium hypochlorite-sodium chlorite method of generating chlorine dioxide is used when chlorine gas is not available. First, sodium hypochlorite is combined with hydrochloric or another acid to form hypochlorous acid. Sodium chlorite is then added to this reaction mixture to produce chlorine dioxide.

#### 4.1.1.2 pH Effects on Chlorine Dioxide Generation

If hypochlorous acid is formed, one of the byproducts of its reaction with sodium chlorite in solution is sodium hydroxide. Since sodium hydroxide is also a common stabilizer of sodium chlorite feedstock, the resulting pH of the mixture can be too high. A high pH slows the formation of chlorine dioxide and impels less efficient chlorate-forming reactions. This is the same process in which chlorite and hypochlorite ions react in drinking water to form chlorate ion. This neutralizing effect of caustic may be influenced by different stabilizers used in each of the types and sources of

sodium chlorite which are approved for use in drinking water under AWWA Standard B303-95 (AWWA, 1995).

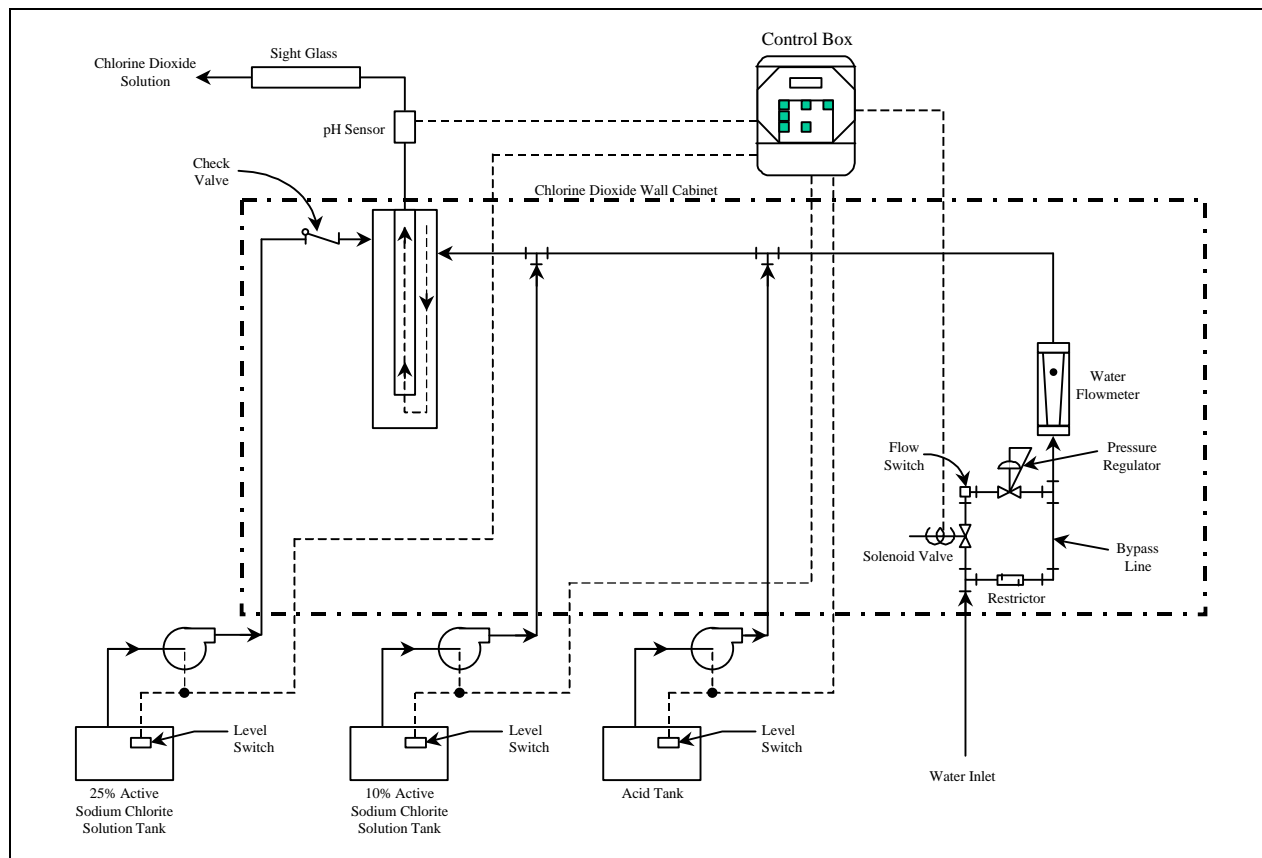

Source: Demers and Renner, 1992.

**Figure 4-2. Chlorine Dioxide Generation Using Recycled Aqueous Chlorine Method**

In very low pH aqueous chlorine solutions, chlorous acid (and not the chlorite ion) may be directly oxidized to chlorine dioxide as shown in reaction [1d]. At this low pH, gaseous chlorine remains "dissolved" in the water at concentrations higher than the normal occurrence, and allows reaction [1a] to proceed.



#### 4.1.1.3 Chlorate Byproduct Formation

One of the most undesirable byproducts in generators is the chlorate ion ( $\text{ClO}_3^-$ ). Chlorate production is possible through reactions with the intermediate dimer,  $\{\text{Cl}_2\text{O}_2\}$ . Rather than the chlorite ion being simply "converted" to chlorine dioxide, reactions [1a] through [1d] can result in the supposed formation of the unstable, unsymmetrical intermediate dimer,  $\{\text{Cl}_2\text{O}_2\}$  or  $\{\text{Cl}^-\text{ClO}_2\}$  as shown in reaction [2] (Emmenegger and Gordon, 1967).



In some generators that operate with relatively low initial reactant concentrations, a significant amount of chlorate is formed by reactions with  $\{Cl_2O_2\}$ , as shown in reactions [3a], [3b], and [3c].

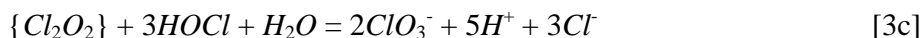

Highly acidic (pH <3) reaction mixtures force the degradation of  $\{Cl_2O_2\}$  to chlorate rather than chlorine dioxide, as well as the direct oxidation of chlorite to chlorate.

The overall reactions that describe chlorate ion formation are:



and

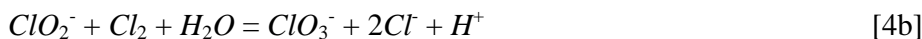

The following conditions may also produce the chlorate ion:

- Excessively high ratios of  $Cl_2$  gas: $ClO_2^-$ .
- Presence of high concentrations of free chlorine at low pH in aqueous solutions.
- Dilute chlorite solutions held at low pH.
- Base-catalyzed disproportionation of chlorine dioxide at high pH values (pH >11).
- Reaction mixtures that are highly acidic (pH <3).
- An excess of hypochlorous acid will directly oxidize chlorite ions to chlorate ions rather than to chlorine dioxide (independent of the rapid formation of the  $\{Cl_2O_2\}$  intermediate).

#### 4.1.4 Generator Design

As hypochlorous acid is formed under acidic conditions, the lowering of optimal concentrations of precursor reactants will also increase chlorate levels in the generator by promoting reaction [3b]. Therefore, if weak precursor feed stocks or high amounts of dilution water are added to the generator, chlorate will be more prevalent (according to reaction [3a]). These limitations explain why generators most often use ~25 percent chlorite solutions and gaseous (or near-saturated aqueous) chlorine. Higher strength solutions of sodium chlorite (e.g., 37 percent) also are more susceptible to crystallization or stratification at ambient temperatures as high as 25°C(78°F).

Due to these dilution effects, some systems function best as "intermittent batch" generators, (that produce high concentrations of chlorine dioxide) rather than as "continuous" generators (that produce lower concentrations (< 1g/L) of chlorine dioxide). The stored solutions are pumped or injected from

the storage tank. Cycling frequently avoids long-term (over 24 hour periods) storage of the generated solution.

Chlorine loop-type systems can obtain high conversion rates if excess chlorine is always present. Excess chlorine permits the molecular chlorine reaction mechanism (described above) to proceed. The low pH of the mixture also minimizes the contribution of  $\text{OH}^-$  formed via equation [1b] by neutralizing it. These solutions may still be contaminated with excess chlorine needed to drive the conversion of chlorite ion, but not to the same degree as found in simple aqueous chlorine systems when operated under dilute conditions. Chlorine-loop generators run best at high capacity since the chlorite ion is most available in this production mode.

Conventional or acid-enhanced generators produce chlorine dioxide through the intermediate  $\{\text{Cl}_2\text{O}_2\}$  as long as relatively high concentrations of reactants (~above 20–30 g/L) are maintained in the reaction chamber prior to dilution. Vapor-phase, recycled loop, and solid chlorite-type generators that minimize dilute aqueous reaction conditions can obtain high efficiencies by preventing any chlorite ion from reacting in the "slower" steps described above. This is accomplished by establishing conditions that force the immediate reaction between chlorite ions and gas-phase or molecular chlorine at a rate hundreds of times faster than the  $\text{Cl}_2$  hydrolysis in water. This essentially minimizes the impact of competitive chlorine hydrolysis or acidification on the dominant  $[\text{ClO}_2^-:\text{Cl}_2 \text{ gas}]$  mechanism, and prevents the chlorite ion reacting with hypochlorous acid directly.

In all generators, large excess amounts of  $\text{Cl}_2$  may result in the over-oxidization of chlorite and directly form chlorate in aqueous solution (reaction [4b]). Precursor chemical feed rates for the generators should always be adjusted to chart settings supplied with generators, notably with the continuous flow, direct gas injection systems. Re-calibration of these systems is sometimes needed on-site if feed stock sodium chlorite is not of the correct strength, or if pre-calibrated flow devices have been replaced.

If aqueous chlorine solutions are mixed with sodium chlorite feed stock solutions, the following mechanisms are dominant, which may affect the formation rates of chlorine dioxide:

- Chlorine gas reacts with water to form hypochlorous and hydrochloric acids, rather than directly with chlorite to form chlorine dioxide. (Water and chlorite both compete for the  $\text{Cl}_2$  molecule simultaneously) (see equations [4.1a-c] and Section 6.1.1).
- Chlorate ion is formed (reactions [3a], [3b], and [3c]).
- Only 4 moles of chlorine dioxide are obtained from 5 moles of sodium chlorite via direct acidification (reaction [1c]). This may become important at low pH and high chloride ion levels.

The practical side of all of this is that different generators operate under different optimal conditions. For example, reactor columns should not be continuously flooded with excess water in vapor-phase systems. It is the main reason why dry chlorite-based generator reactor columns should not get wet. Over-dilution of the precursor reactants themselves will lower conversion efficiencies due to the

avored formation of chlorate over chlorine dioxide. Batch-type generation should always be carried out at maximal  $\text{ClO}_2$  concentration with appropriate adjustments at the pump (located downstream of the reactor at the batch tank) for dosage or flow. Changes in chlorine dioxide concentrations in the batch tanks would then be minimized, and pump calibration does not need to include a broad range of chlorine dioxide levels. For the newer gas chlorine generators using dry sodium chlorite in an inert matrix, small amounts of humidifying water in the mixture do not interfere significantly with the simple gaseous  $\text{Cl}_2:\text{ClO}_2^-$  reaction. These small traces of water allow for continuous exposure of  $\text{ClO}_2^-$  on the inert surfaces within the reactor column.

Chlorine dioxide generators are relatively simple mixing chambers. The reactors are frequently filled with media (Teflon™ chips, ceramic or raschig rings) to generate hydraulic turbulence for mixing. A sample petcock valve on the discharge side of the generator is desirable to allow for monitoring of the generation process.

The *Recommended Standards for Water Works* (GLUMRB, 1992) and drinking water design textbooks such as *Unit Processes in Drinking Water Treatment* by Masschelein (1992) are excellent sources for chlorine dioxide generation design criteria and application.

### 4.1.5 Chemical Feed Systems

Fiberglass Reinforced vinyl ester Plastic (FRP) or High Density Linear Polyethylene (HDLPE) tanks with no internal insulation or heat probes are recommended for bulk storage of 25 to 38 percent solution sodium chlorite. Nozzles should include truck unloading vents and local level and temperature indication. Transfer pumps should be centrifugal with 316 stainless steel, fiberglass, Hypalon™, wetted Teflon™ parts, or epoxy resins. The pump should be sealless or equipped with double mechanical seals. The recommended piping material is CPVC, although vinyl ester or Teflon™ piping systems are acceptable. Carbon steel and stainless steel piping systems are not recommended.

Depending upon system size, sodium chlorite can be purchased in 55-gallon drums, 275-gallon non-returnable totes, or in bulk quantities. A 30-day storage supply of sodium chlorite can easily be met for most small systems by using 55-gallon drums. A 55-gallon drum weighs approximately 600 lbs. Equipment should be provided such that one person can easily handle a drum. All gaseous chlorine or hypochlorite solution-related plumbing should follow Chlorine Institute directives.

Storage and chlorine dioxide systems typically include the following:

- Storage and feeding in a designated space.
- Use of non-combustible materials such as concrete for construction.
- Storage in clean, closed, non-translucent containers. Exposure to sunlight, UV light, or excessive heat will reduce product strength.



- Avoid storage and handling of combustible or reactive materials, such as acids or organic materials, in the sodium chlorite area.
- Secondary containment for storage and handling areas to handle the worse case spill with sumps provided to facilitate recovery.
- A water supply near storage and handling areas for cleanup.
- Inert material should be used in contact with the strong oxidizing and/or acid solutions involved in chlorine dioxide systems.
- Storage tanks with vents to outside.
- Adequate ventilation and air monitoring.
- Gas masks and first aid kits outside of the chemical areas.
- Reactor with glass view ports if it is not made of transparent material.
- Flow monitoring on all chemical feed lines, dilution water lines, and chlorine dioxide solution lines.
- Dilution water should not be excessively hard in order to avoid calcium deposits and should be near neutral pH.
- On-site and frequent testing of chemical solution strengths should be practiced to achieve efficient process control.
- Air contact with chlorine dioxide solutions should be controlled to limit the potential for explosive concentrations possibly building up within the generator. Chlorine dioxide concentrations in air higher than 8 to 10 percent volume should be avoided. Two methods can be applied: operation under vacuum or storage under higher positive pressure (45 to 75 psig) to prevent buildup of gas-phase  $\text{ClO}_2$  in the head space. Bulk storage (batch) tanks containing  $\text{ClO}_2$  should be suitably vented to atmosphere.

Sodium chlorite solution feed pumps are commonly diaphragm-metering pumps for liquid feed rate control. If centrifugal pumps are used, the only acceptable packing material is Teflon. If lubrication is needed, minimum quantities of fire-resistant lubricants should be used. Pump motors should be totally enclosed, fan-cooled (TEFC) with sealed-for-life bearings. Couplings should be of the greaseless type. Water lines for mechanical seals should have a pressure gauge and throttling valve on the outlet side. Visual means should be provided to verify adequate water flow. Each pump should include a calibration chamber.

Pipes carrying sodium chlorite should be provided sufficient support to minimize risk of overstressing joints. Flexible connections to pumps should also be provided to minimize risk of vibration damage. Pipe should be sloped to drainage points and valved hose connections provided at strategic points for efficient flushing and draining. Service water for flushing feed lines should be introduced only through temporarily connected hoses protected by a backflow preventer. Service water lines should include check valves. Hose connections from service water lines should have a vent valve to release pressure before the hose is disconnected after use.

Flows are frequently measured with magnetic flow meters, mass flow meters, or rotameters for precise control. Provisions should always be made for back-flow prevention. Sodium chlorite is extremely reactive, especially in the dry form, and care should be taken to protect against potentially explosive conditions.

Chlorine dioxide solution concentrations below about 10 g/L will not produce sufficiently high vapor pressures to present an explosion hazard under most ambient conditions of temperature and pressure. In water treatment, chlorine dioxide solution concentrations rarely exceed 4 g/L for temperatures less than 40°C, and treatment levels generally range from 0.1 to 5.0 mg/L. If temperatures exceed 50°C, storage tanks should be suitably vented due to the higher levels of ClO<sub>2</sub> possible. As cold service/potable water is typically used as generator dilution water, these conditions are rarely encountered.

#### 4.1.6 Generator Power Requirements

Generator power requirements are similar to those for chlorination systems. For all generators (20 to 12,000 lb/day) power can be supplied from 120 VAC single phase, to 480 VAC three phase. Power demand will vary based upon make-up water pressure available to operate the venturi. Fractional horsepower metering pumps are required, based upon system configuration.

### 4.3 Primary Uses and Points of Application for Chlorine Dioxide

The calculation of CT for chlorine dioxide is similar to other disinfectants, with accurate determinations of residual concentrations being a prerequisite for effective disinfection. Primary disinfectant credit is achieved by the residual concentration and the effective contact time. It has been found in practice that because of the volatile nature of the gas, chlorine dioxide works extremely well in plug flow reactors such as pipe lines. It can be easily removed from dilute aqueous solution by turbulent aeration in rapid mix tanks or purging in recarbonation basins. CT credits should not be expected through a filter because the likelihood that no residual remains in the filtered water (DeMers and Renner, 1992). For post CT disinfection credit, chlorine dioxide can be added before clearwells or transfer pipelines. Ample sampling points should be included to allow close monitoring of residual concentrations. It is well known that chlorine dioxide is commonly destroyed by UV in basins exposed to sunlight or bright fluorescent lights. Therefore, protective design elements should be incorporated if such exposure is anticipated.

#### 4.3.1 Disinfection

Before chlorine dioxide is selected for use as a primary disinfectant an oxidant demand study should be completed. Ideally, this study should consider the seasonal variations in water quality, temperature, and application points. Table 4-2 shows typical results for a single sample of a demand study completed on a surface water source.

The MRDL for chlorine dioxide is 0.8 mg/L and the MCL for chlorite is 1.0 mg/L per the D/DBP rule. This means that if the oxidant demand is greater than about 1.4 mg/L, chlorine dioxide may not be used as a disinfectant because the chlorite/chlorate ions byproduct, might exceed the maximum level allowed, unless inorganic byproducts (e.g., chlorite) are subsequently removed. There are numerous means to reduce excessive chlorite levels prior to chlorination in conventional water plants.

**Table 4-2. Surface Water Chlorine Dioxide Demand Study Results**

Dose (mg/L)	Time (min)	ClO <sub>2</sub> (mg/L)	ClO <sub>2</sub> <sup>-</sup> (mg/L)	ClO <sub>3</sub> <sup>-</sup> (mg/L)
1.4	3	0.47	0.76	0.05
	10	0.30	0.98	0.06
	20	0.23	1.08	0.07
	40	0.16	1.11	0.07
	60	0.11	1.11	0.07

Source: DeMers and Renner, 1992.

Note: \*Raw water sample, 23°C, 8.5 pH.

Typical dosages of chlorine dioxide used as a disinfectant in drinking water treatment range from 0.07 to 2.0 mg/L. For plants using chlorine dioxide, median concentrations of chlorite and chlorate were found to be 0.24 and 0.20 mg/L, respectively in an EPA survey (USEPA, 1998), the standard is 1.0 mg/L.

### 4.3.2 Taste and Odor Control

A common application of chlorine dioxide in drinking water in the United States has been for control of tastes and odors associated with algae and decaying vegetation. Chlorine dioxide is also effective in destroying taste and odor producing phenolic compounds. The recommended location for application of chlorine dioxide for this purpose will depend on raw water quality, the type of treatment plant and any other purposes for chlorine dioxide addition. In conventional treatment plants, it is recommended that chlorine dioxide be added near the end of or following, the sedimentation basin. If the raw water turbidity is low (for example, less than 10 NTU), chlorine dioxide can be added at the beginning of the plant. Some utilities follow this practice because chlorine dioxide is effective in controlling algae growth in flocculation and sedimentation basins that are exposed to sunlight (DeMers and Renner, 1992). Such application during periods of darkness may be more successful for nuisance algae control.

### 4.3.3 Oxidation of Iron and Manganese

Chlorine dioxide can be used to oxidize both iron and manganese. Chlorine dioxide reacts with the soluble forms of iron and manganese to form precipitates that can be removed through sedimentation and filtration. Chlorine dioxide reduces to chlorite ion in this reaction (Knocke et al., 1993). About 1.2 mg/L of chlorine dioxide is required to remove 1.0 mg/L of iron, and 2.5 mg/L of chlorine dioxide are required to remove 1.0 mg/L of manganese. For high concentrations of iron and manganese, the use of chlorine dioxide is limited to the 1.0 mg/L chlorite/chlorate ion byproduct, as

described before. Ferrous iron may be added prior to conventional coagulation to chemically reduce chlorite ion (to chloride ion) and improve the overall flocculation process.

## 4.4 Pathogen Inactivation and Disinfection Efficacy

For water treatment, chlorine dioxide has several advantages over chlorine and other disinfectants. In contrast to chlorine, chlorine dioxide remains in its molecular form in the pH range typically found in natural waters (Roberts et al., 1980). Chlorine dioxide is a strong oxidant and disinfectant. Its disinfection mechanisms are not well understood, but appear to vary by type of microorganism

### 4.4.1 Inactivation Mechanisms

Gross physical damage to bacterial cells or viral capsids has not been observed at the low concentrations of chlorine dioxide typically used to disinfect drinking water. Therefore, studies have focused primarily on two more subtle mechanisms that lead to the inactivation of microorganisms: determining specific chemical reactions between chlorine dioxide and biomolecules; and observing the effect chlorine dioxide has on physiological functions.

In the first disinfection mechanism, chlorine dioxide reacts readily with amino acids cysteine, tryptophan, and tyrosine, but not with viral ribonucleic acid (RNA) (Noss et al., 1983; Olivier et al., 1985). From this research, it was concluded that chlorine dioxide inactivated viruses by altering the viral capsid proteins. However, chlorine dioxide reacts with poliovirus RNA and impairs RNA synthesis (Alvarez and O'Brien, 1982). It has also been shown that chlorine dioxide reacts with free fatty acids (Ghandbari et al., 1983). At this time, it is unclear whether the primary mode of inactivation for chlorine dioxide lies in the peripheral structures or nucleic acids. Perhaps reactions in both regions contribute to pathogen inactivation.

The second type of disinfection mechanism focuses on the effect of chlorine dioxide on physiological functions. It has been suggested that the primary mechanism for inactivation was the disruption of protein synthesis (Bernarde et al., 1967a). However, later studies reported the inhibition of protein synthesis may not be the primary inactivation mechanism (Roller et al., 1980). A more recent study reported that chlorine dioxide disrupted the permeability of the outer membrane (Aieta and Berg, 1986). The results of this study were supported by the findings of Olivieri et al. (1985) and Ghandbari et al. (1983), which found that the outer membrane proteins and lipids were sufficiently altered by chlorine dioxide to increase permeability.

### 4.4.2 Environmental Effects

Studies have been performed to determine the effect of pH, temperature, and suspended matter on the disinfection efficiency of chlorine dioxide. Following is a summary of the effects these parameters have on pathogen inactivation.

#### 4.4.2.1 pH

In comparison to chlorine, studies have shown that pH has much less effect on pathogen inactivation for viruses and cysts with chlorine dioxide than with chlorine in the pH range of 6 to 8.5. Unlike chlorine, studies on chlorine dioxide have shown the degree of inactivation of poliovirus 1 (Scarpino et al., 1979) and *Naegleria gruberi* cysts (Chen et al., 1984) increase as the pH increases.

The results of studies on *E. coli* inactivation are inconclusive. It has been found that the degree of inactivation by chlorine dioxide increases as pH increases (Bernarde et al., 1967a). However, an earlier study found that the bactericidal activity of chlorine dioxide was not affected by pH values in the range of 6.0 to 10.0 (Ridenour and Ingols, 1947). A recent study on *Cryptosporidium* found that inactivation of oocysts using chlorine dioxide occurred more rapidly at a pH of 8.0 than 6.0. At a similar CT value, the level of inactivation at pH of 8.0 was approximately twice that at a pH of 6.0 (Le Chevallier et al., 1997). Another study found that chlorine dioxide efficacy increases for *Giardia* inactivation at higher pH levels and that this may be the result of chemical or physical changes in *Giardia* cyst structure rather than pH effects on chlorine dioxide disproportionation (Liyanage et al., 1997). More research is needed to further clarify how pH impacts the effectiveness of chlorine dioxide.

#### 4.4.2.2 Temperature

Similar to chlorine, the disinfection efficiency of chlorine dioxide decreases as temperature decreases (Ridenour and Ingols, 1947). This finding is supported by the data from Chen et al. (1984) shown in Figure 4-3 for the inactivation of *Naegleria gruberi* cysts. The curve shows the CT required to achieve 99 percent inactivation for temperatures between 5 and 30°C.

In a more recent study, LeChevallier et al. (1997) found that reducing the temperature from 20°C to 10°C reduced the disinfection effectiveness of chlorine dioxide on *Cryptosporidium* by 40 percent, which is similar to previous results for *Giardia* and viruses. Gregory et al. (1998) found that even under the most favorable conditions (i.e., at a pH of 8.5), required doses to achieve 2-log *Cryptosporidium* inactivation do not appear to be a feasible alternative, requiring doses of more than 3.0 mg/L with a 60 minute detention time. At neutral pH levels, the required doses may be more than 20 mg/L.

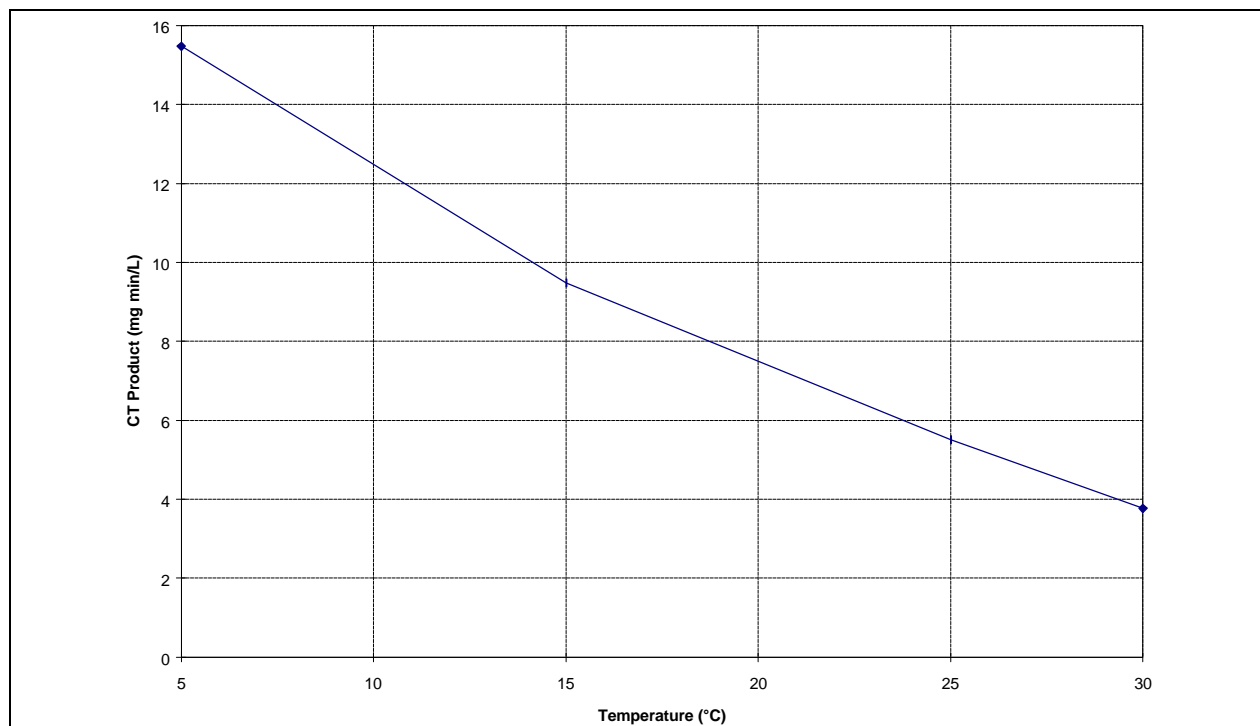

**Figure 4-3. Effect of Temperature on *N. Gruberi* Cyst Inactivation at pH 7**

#### **4.4.2.3 Suspended Matter**

Suspended matter and pathogen aggregation affect the disinfection efficiency of chlorine dioxide. Protection from chlorine dioxide inactivation due to bentonite was determined to be approximately 11 percent for turbidities equal to or less than 5 NTUs and 25 percent for turbidities between 5 and 17 NTUs (Chen et al., 1984).

Laboratory studies of poliovirus 1 preparations containing mostly viral aggregates took 2.7 times longer to inactivate with chlorine dioxide than single state viruses (Brigano et al., 1978). Chen et al. (1984) also found that clumps of *Naegleria gruberi* cysts were more resistant to chlorine dioxide than unclumped cysts or clumps of smaller size.

### **4.4.3 Disinfection Efficacy**

Several investigations have been made to determine the germicidal efficiency of chlorine dioxide since its introduction in 1944, as a drinking water disinfectant. Most of the investigations were carried out as a comparison to chlorine; some studies have compared chlorine dioxide and ozone. Chloride dioxide is a more effective disinfectant than chlorine but is less effective than ozone.

#### **4.4.3.1 Bacteria Inactivation**

Quantitative data were published as early as the 1940s demonstrating the efficacy of chlorine dioxide as a bactericide. In general, chlorine dioxide has been determined to be equal to or superior to chlorine on a mass-dose basis. It was demonstrated that even in the presence of suspended matter,

chlorine dioxide was effective against *E. coli* and *Bacillus anthracoides* at dosages in the range of 1 to 5 mg/L (Trakhtman, 1949). Ridenour and Armbruster (1949) reported that an orthotolidine arsenite (OTA) chlorine dioxide residual of less than 1 mg/L was effective against *Eberthella typhosa*, *Shigella dysenteriae*, and *Salmonella paratyphi* B. Under similar pH and temperature slightly greater OTA residuals were required for the inactivation of *Pseudomonas aeruginosa* and *Staphylococcus aureus*.

Chlorine dioxide was shown to be more effective than chlorine at inactivating *B. subtilis*, *B. mesentericus*, and *B. megatherium* spores (Ridenour et al., 1949). Moreover, chlorine dioxide was shown to be just as effective or more effective than chlorine at inactivating *Salmonella typhosa* and *S. paratyphi* (Bedulivich et al., 1954).

In the early 1960s several important contributions were made by Bernarde et al. (1967a and 1967b). Chlorine dioxide was found to be more effective than chlorine at disinfecting sewage effluent and the rate of inactivation was found to be rapid.

A comprehensive investigation of chlorine dioxide as disinfectant was performed by Roberts et al. (1980). The investigation was performed using secondary effluents from three different wastewater treatment plants. One of the objectives was to determine the relationships between dosages and contact times and bactericidal efficiency. Dosages were compared for 2, 5, and 10 mg/L of chlorine dioxide and chlorine. The contact times selected were 5, 15 and 30 minutes. Results of the investigation are shown in Figure 4-4. As shown, chlorine dioxide demonstrated a more rapid coliform inactivation than chlorine at the shortest contact time of 5 minutes and higher concentrations. However, after 30 minutes of contact time, chlorine dioxide was equal or slightly less efficient than chlorine as a bactericide.

Oliveri et al. (1984) studied the effectiveness of chlorine dioxide (and chlorine) residuals in inactivating total coliform and f2 coliphage virus in sewage introduced to a water distribution system. Initial chlorine dioxide residuals between 0.85 and 0.95 mg/L resulted in an average 2.8-log inactivation of the total coliform and an average 4.4-log inactivation of the f2 coliphage virus, over a contact time of 240 minutes.

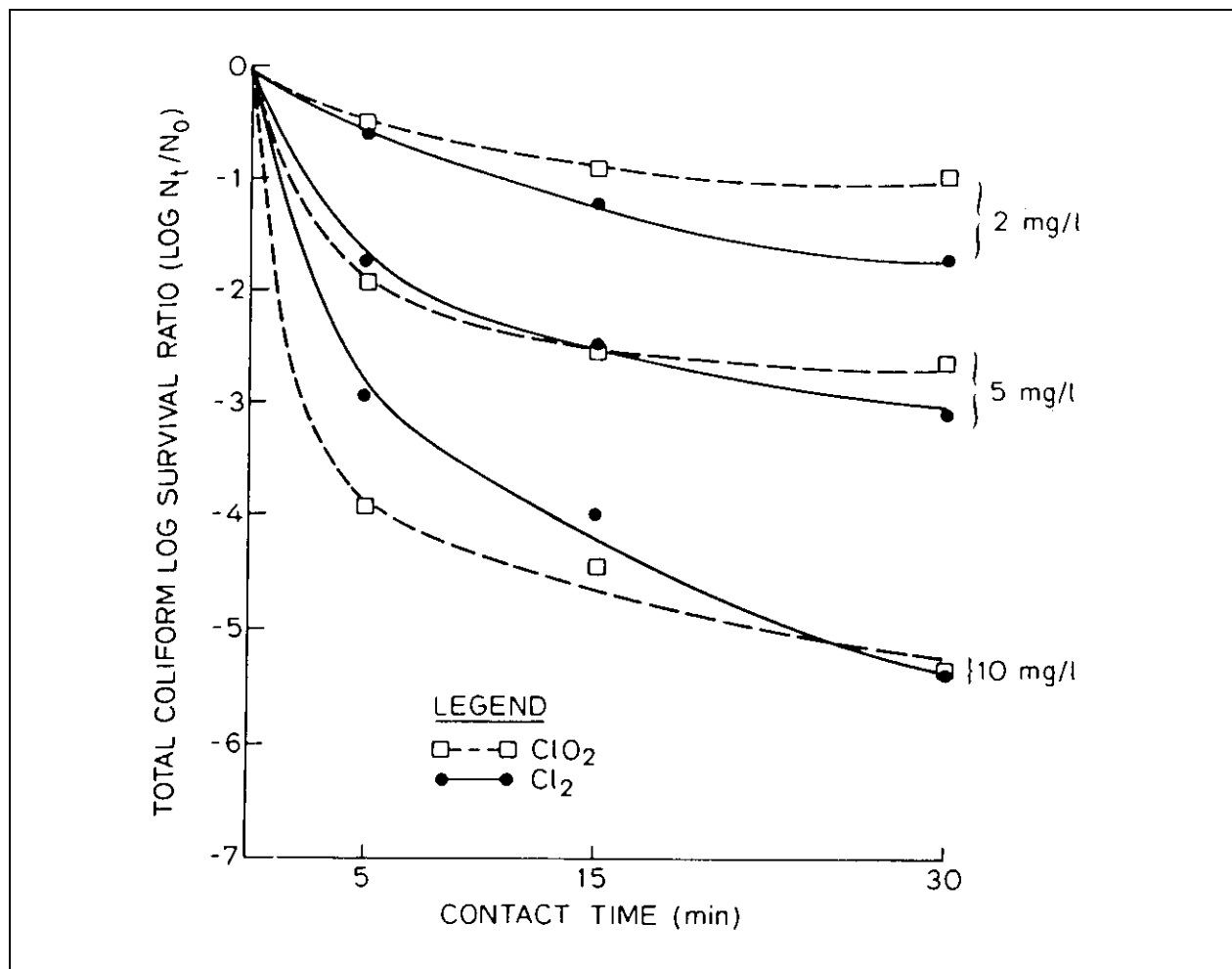

Source: Roberts et al., 1980.

**Figure 4-4. Comparison of Germicidal Efficiency of Chlorine Dioxide and Chlorine**

#### 4.4.3.2 Protozoa Inactivation

The disinfection efficiency of chlorine dioxide has been shown to be equal to or greater than chlorine for *Giardia* inactivation. Based on a 60 minute contact time, chlorine dioxide doses in the range of 1.5 to 2 mg/L are capable of providing a 3-log *Giardia* inactivation at 1°C to 25°C and pHs of 6 and 9 (Hofmann et al., 1997). Depending on the temperature and pH, *Cryptosporidium* has been found to be 8 to 16 times more resistant to chlorine dioxide than *Giardia* (Hofmann et al., 1997). Although some *Cryptosporidium* oocysts remained viable, one group of researchers found that a 30-minute contact time with 0.22 mg/L chlorine dioxide could significantly reduce oocyst infectivity (Peeters et al., 1989). In contrast, other researchers have found that CT values in the range of 60 to 80 mg·min/L were necessary to provide 1- to 1.5-log inactivation (Korich et al., 1990; Ransome et al., 1993). Finch et al. (1995) reported that the CT values for 1-log inactivation was in the range of 27 to 30 mg·min/L. For 2-log inactivation, the CT value was approximately 40 mg·min/L, and 70 mg·min/L for 3-log inactivation. Finch et al. (1997) found 3-log inactivation of *Cryptosporidium* oocysts with initial chlorine dioxide residual concentrations of 2.7 and 3.3 mg/L for contact times of 120 minutes, at pH of 8.0 and a temperature of 22°C.



Both Chen et al. (1985) and Sproul et al. (1983) have investigated the inactivation of *Naegleria gruberi* cysts by chlorine dioxide. Both studies concluded that chlorine dioxide is an excellent disinfectant against cysts and that chlorine dioxide is better than or equal to chlorine in terms of inactivation. Chlorine dioxide was found to be superior to chlorine at higher pHs. However, the authors cautioned that the CT required for 2-log inactivation was much higher than normally employed for water treatment at that time.

#### **4.4.3.3 Virus Inactivation**

Chlorine dioxide has been shown to be an effective viricide. Laboratory studies have shown that inactivation efficiency improves when viruses are in a single state rather than clumped. It was reported in 1946 that chlorine dioxide inactivated *Poliomyelitis* (Ridenour and Ingols, 1946). This investigation also showed that chlorine dioxide and free chlorine yielded similar results. Other studies have verified these findings for poliovirus 1 (Cronier et al., 1978) and *Coxsackie* virus A9 (Scarpino, 1979). At greater than neutral pHs (where hypochlorite ion is the predominant species) chlorine dioxide has been found to be superior to chlorine in the inactivation of numerous viruses such as echovirus 7, coxsackie virus B3, and sendai virus (Smith and McVey, 1973). Sobsey (1998) determined CT values based on a study of Hepatitis A virus, strain HM 175. The study found 4-log inactivation levels are obtainable at CT values of less than 35 at 5°C and less than 10 at a temperature of 25°C.

#### **4.4.3.4 CT Values**

Chlorine dioxide is regarded as a strong disinfectant that is effective at inactivating bacterial, viral, and protozoan pathogens. CT values for *Giardia* and virus inactivation are shown in Figure 4-5 and Figure 4-6, respectively (AWWA, 1991).

CT values shown in Figure 4-5 are based on disinfection studies using in vitro excystation of *Giardia muris*. Average CT values for 2 log removal were extrapolated using first order kinetics and multiplied by a safety factor of 1.5 to obtain the CT values for other log removal CT values. Due to the limited amount of data available at pH values other than 7, the same CT values are used for all pHs. Because chlorine dioxide is more effective at a pH 9 than at a pH of 7, the CT values shown in Figure 4-5 are more conservative for higher pHs than for lower pHs. A lower safety factor was used to derive the CT values for chlorine dioxide than for ozone due to the fact that the chlorine dioxide values were derived from *Giardia muris* studies, which are more resistant than *Giardia lamblia*.

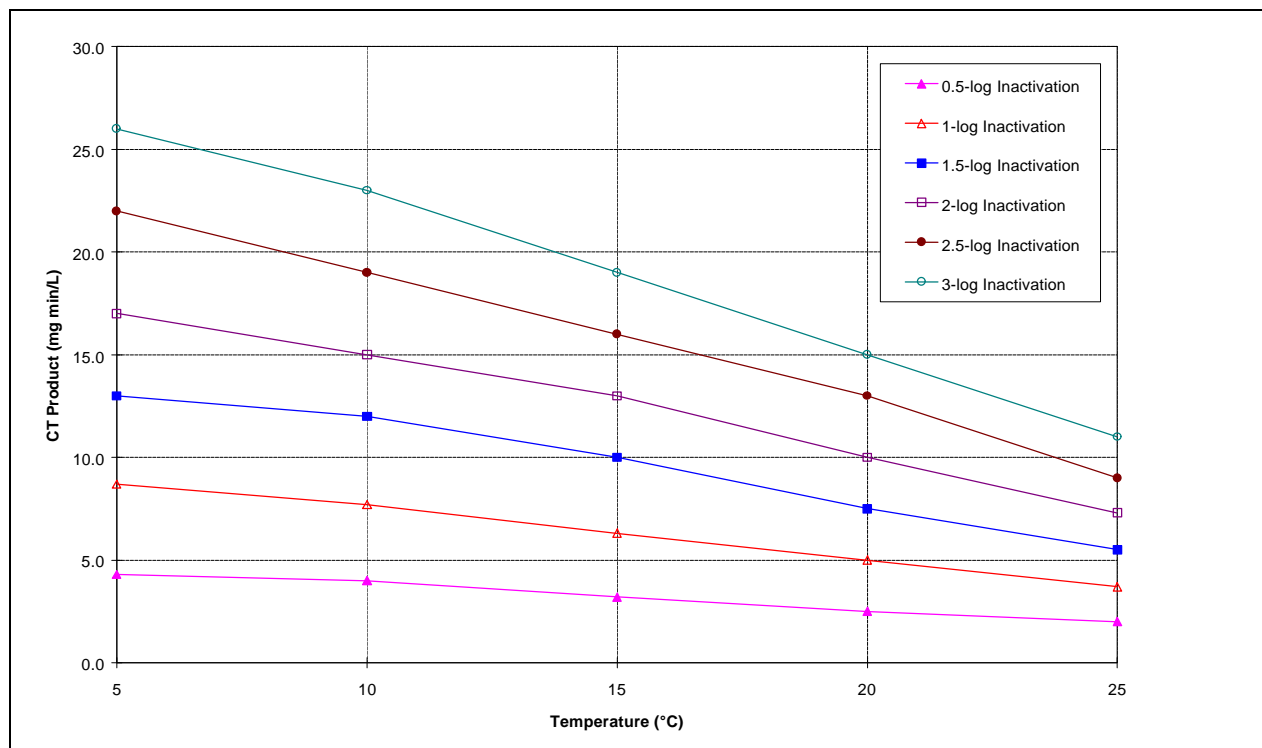

Source: AWWA, 1991.

**Figure 4-5. CT Values for Inactivation of *Giardia* Cysts by Chlorine Dioxide**

CT values shown in Figure 4-6 were obtained by applying a safety factor 2 to the average CT values derived from the studies on hepatitis A virus, strain HM 175 (Sobsey, 1988). CT values at temperatures other than 5°C were derived by applying a twofold decrease for every 10°C increase in temperature.

Figure 4-7 and Figure 4-8 show the relationship between CT products and log inactivation of *Cryptosporidium* at 20 and 10°C, respectively, and pHs of 6 and 8. CT values shown in Figure 4-7 and Figure 4-8 indicate that oocysts were more rapidly inactivated at pH 8 than 6 and that temperature does impact the disinfection efficiency of chlorine dioxide. Reducing the temperature from 20 to 10°C reduced the disinfection effectiveness by 40 percent. Finch (1997) is studying *Cryptosporidium* inactivation under laboratory conditions using a variety of different disinfectants, one of which is chloride dioxide.

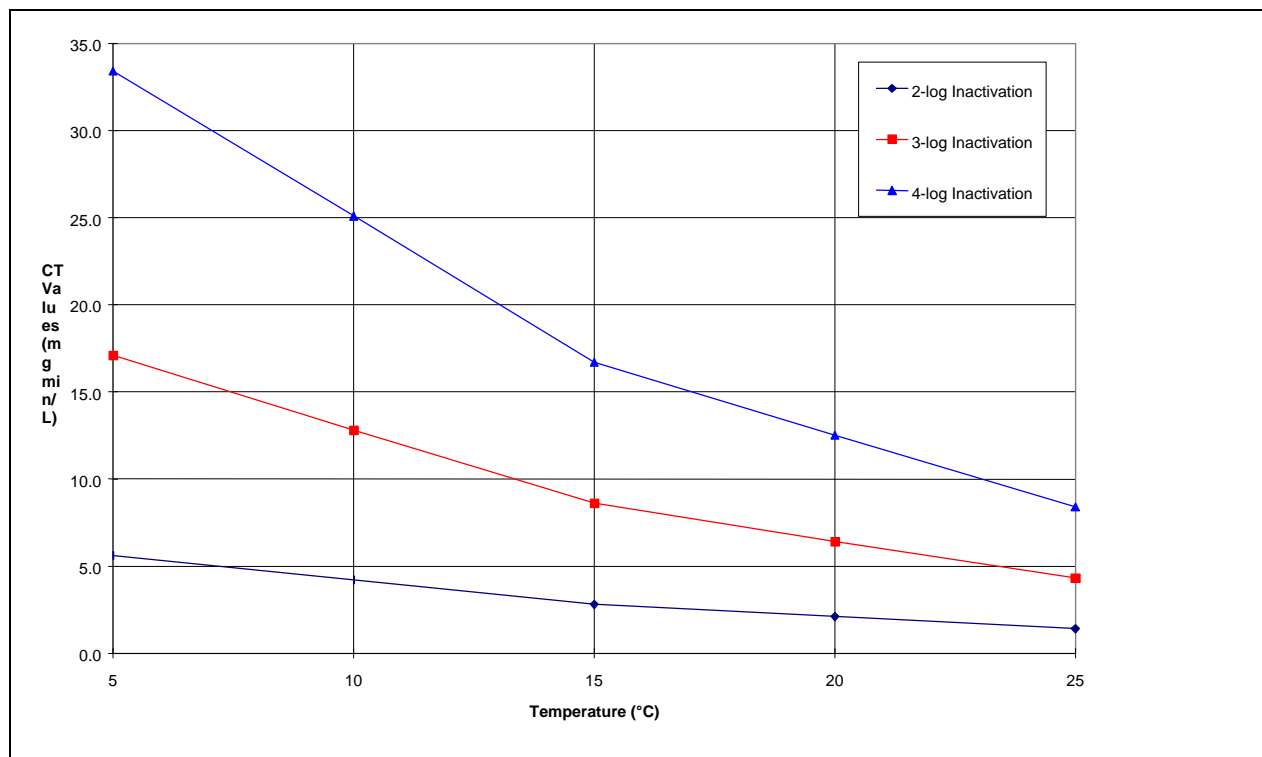

Source: AWWA, 1991.

**Figure 4-6. CT Values for Inactivation of Viruses by Chlorine Dioxide**

## 4.5 Chlorine Dioxide Disinfection Byproducts

Byproducts from the use of chlorine dioxide include chlorite, chlorate, and organic DBPs. This section discusses the formation of these byproducts and methods to reduce or remove these DBPs. The use of chlorine dioxide aids in reducing the formation of TTHMs and HAAs by oxidizing precursors, and by allowing the point of chlorination to be moved farther downstream in the plant after coagulation, sedimentation, and filtration have reduced the quantity of NOM.

### 4.5.1 Production of Chlorite and Chlorate

Chlorite and chlorate are produced in varying ratios as endproducts during chlorine dioxide treatment and subsequent degradation. The primary factors affecting the concentrations of chlorine dioxide, chlorite, and chlorate in finished drinking water involve:

- Dosage applied/oxidant demand ratio.
- Blending ratios of sodium chlorite and chlorine during the chlorine dioxide generation process.
- Exposure of water containing chlorine dioxide to sunlight.

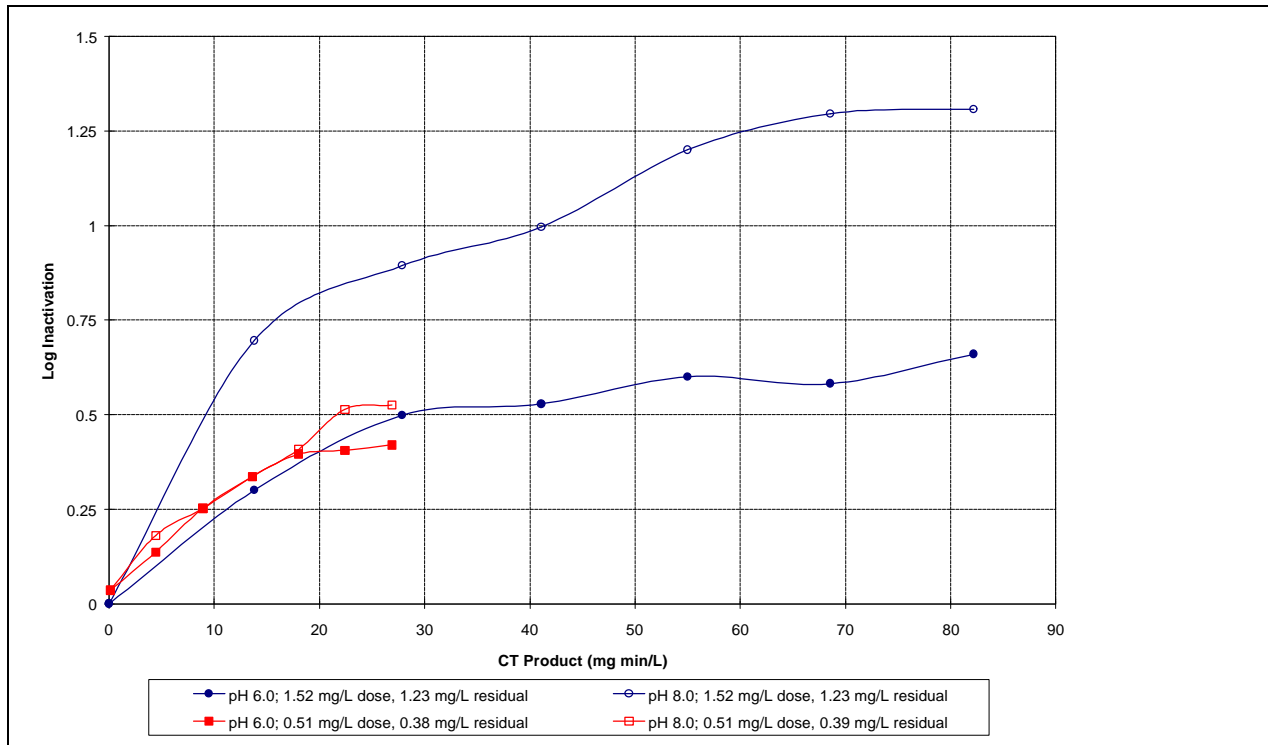

Source: LeChevallier et al., 1996.

**Figure 4-7. *C. parvum* Inactivation by Chlorine Dioxide at 20°C**

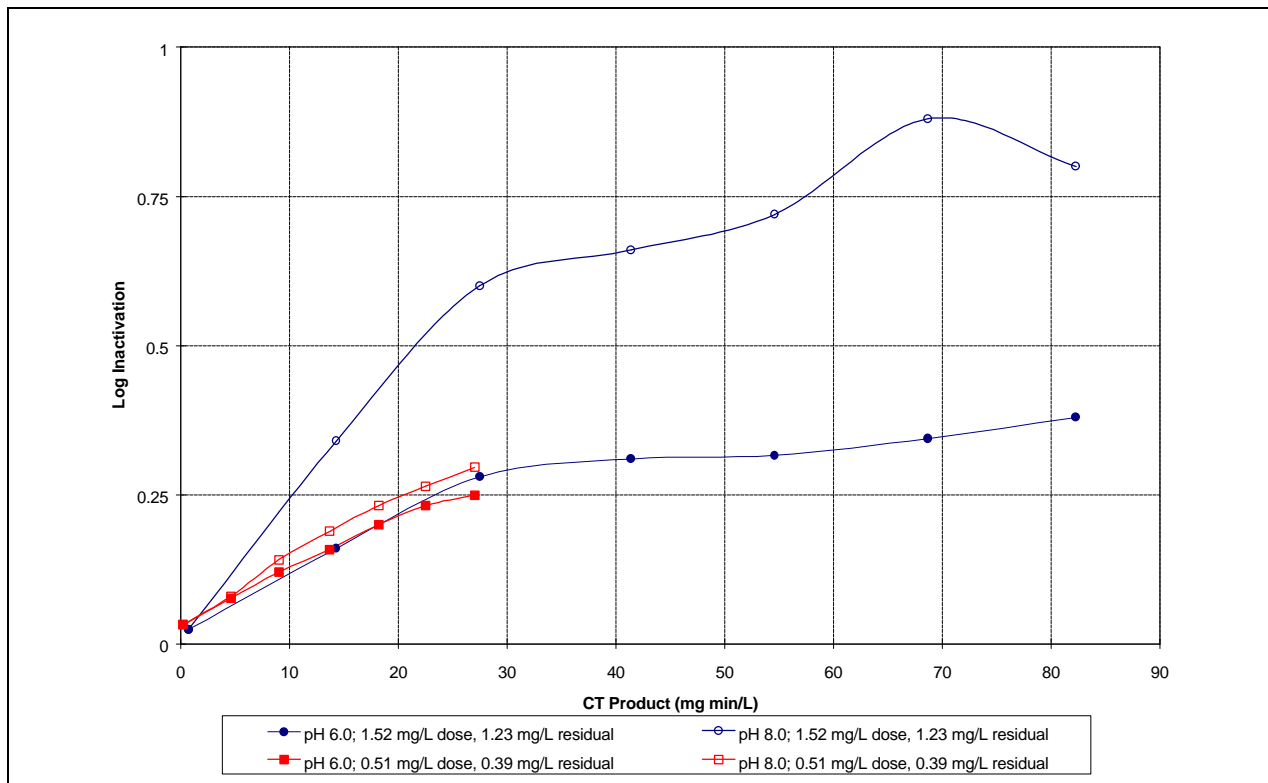

Source: LeChevallier et al., 1996.

**Figure 4-8. *C. parvum* Inactivation by Chlorine Dioxide at 10°C**

- Reactions between chlorine and chlorite if free chlorine is used for distribution system residual maintenance.
- Levels of chlorate in sodium chlorite feedstock.

Incomplete reaction or non-stoichiometric addition of the sodium chlorite and chlorine reactants can result in unreacted chlorite in the chlorine dioxide feed stream. Dilute chlorine dioxide solutions are stable under low or zero oxidant-demand conditions. The quantity of chlorate produced during the chlorine dioxide generation process is greater with excess chlorine addition. Likewise, a low or high pH can increase the quantity of chlorate during the chlorine dioxide generation process. See Section 4.2, "Generation," for a detailed discussion of the chemistry of chlorine dioxide generation.

Numerous inorganic and biological materials found in raw water will react with chlorine dioxide (Noack and Doerr, 1977). Chloride ( $\text{Cl}^-$ ) and chlorite ( $\text{ClO}_2^-$ ) ions are the dominant degradation species arising from these reactions, although chlorate ( $\text{ClO}_3^-$ ) can appear for a variety of reasons when chlorine dioxide is used (Gordon et al., 1990; Werdehoff and Singer, 1987). The immediate redox reactions with natural organic matter play the dominant role in decay of chlorine dioxide into chlorite in drinking water (Werdehoff and Singer, 1987). Chlorite ion is generally the primary product of chlorine dioxide reduction. The distribution of chlorite and chlorate is influenced by pH and sunlight. Approximately 50 to 70 percent of the chlorine dioxide consumed by oxidation reactions is converted to chlorite under conditions typical in water treatment (Rav-Acha et al., 1984; Werdehoff and Singer, 1987). The application of 2 mg/L chlorine dioxide is expected to produce 1 to 1.4 mg/L of chlorite (Singer, 1992).

Chlorite is relatively stable in the presence of organic material but can be oxidized to chlorate by free chlorine if added as a secondary disinfectant (Singer and O'Neil, 1987).

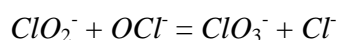

Chlorate is therefore produced through the reaction of residual chlorite and free chlorine during secondary disinfection.

In addition, chlorine dioxide also disproportionates under highly alkaline conditions ( $\text{pH} > 9$ ) to chlorite and chlorate according to the following reaction:



In water treatment processes that require high pH, such as softening, chlorine dioxide should be added after the pH has been lowered (Aieta et al., 1984).

The occurrence of photochemical decomposition of chlorine dioxide can affect the ultimate concentrations of chlorine dioxide, chlorite, and chlorate in water treated with chlorine dioxide. Moreover, generally, sunlight may increase chlorate concentrations in uncovered storage basins containing water with chlorine dioxide residuals. Exposure to ultraviolet light will also change the potential reactions between chlorine dioxide and the bromide ion.

## 4.5.2 Organic DBPs Produced by Chlorine Dioxide

Chlorine dioxide generally produces few organic DBPs. However, Singer (1992) noted that the formation of non-halogenated organic byproducts of chlorine dioxide has not been adequately researched, and expected that chlorine dioxide will produce the same types of oxidation byproducts that are produced through ozonation. The application of chlorine dioxide does not produce THMs and produces only a small amount of total organic halide (TOX) (Werdehoff and Singer, 1987).

A study was conducted in 1994 by Richardson et al., to identify semivolatile, organic DBPs produced by chlorine dioxide treatment in drinking water. Samples were taken from a pilot plant in Evansville, Indiana that included the following treatment variations:

- Aqueous chlorine dioxide;
- Aqueous chlorine dioxide, ferrous chloride, ( $\text{FeCl}_2$ ), chlorine ( $\text{Cl}_2$ ), and dual media filtration (sand and anthracite);
- Gaseous chlorine dioxide; and
- Gaseous chlorine dioxide, ferrous chloride ( $\text{FeCl}_2$ ), chlorine ( $\text{Cl}_2$ ), and dual media filtration (sand and anthracite).

Using multispectral identification techniques, more than 40 different DBPs (many at sub-nanogram/L [ng/L] levels) were identified including carboxylic acids and maleic anhydrides isolated from XAD<sup>TM</sup> concentrates, some of which may be regulated in the Stage 2 DBPR. THMs were not found after chlorine dioxide was added to the water; however, THMs did show up during subsequent chlorination.

## 4.5.3 Chlorine Dioxide DBP Control Strategies

EPA recommends that the total concentration of chlorine dioxide, chlorite, and chlorate be less than 1.0 mg/L as  $\text{Cl}_2$  (USEPA, 1983). In addition, chlorine dioxide concentrations exceeding 0.4 to 0.5 mg/L contribute to taste and odor problems (AWWA, 1990). Due to these issues, the use of chlorine dioxide to provide a disinfectant residual is somewhat limited in moderate to high TOC water. In low oxidant-demand water, however,  $\text{ClO}_2$  residuals may last several days.

Once formed, chlorate is stable in finished drinking water. No known treatment exists for removing chlorate once it is formed. However, three strategies (Gallagher et al., 1994) that have been proven effective for chlorite removal are:

- Adding reduced-sulfur compounds such as sulfur dioxide and sodium sulfite (not recommended).
- Applying either granular activated carbon (GAC) or powdered activated carbon (PAC).
- Adding reduced iron salts, such as ferrous chloride and ferrous sulfate.

Chlorite removal from drinking water through sulfur dioxide and other sulfur-based reducing agents has been reported effective, but not desirable. A study of chlorite removal by sulfur dioxide indicates that a lower pH level yields higher chlorite removal, and chlorite removal efficiencies increase as the sulfur dioxide dose increases. Unfortunately, this removal process forms significant levels of chlorate when sulfur dioxide and metarsulfite are utilized. Therefore, it is concluded that treatment with sulfur dioxide and metarsulfite is not desirable for chlorite removal (Dixon and Lee, 1991). In addition, sodium thiosulfate results in effective chlorite reduction, but the degree of removal is highly dependent upon pH and contact time and relatively high dosages are required. Again, this application of sodium thiosulfate is not desirable because the required dosages are too high (Griese et al., 1991).

The addition of ferrous iron in drinking water is effective for chlorite removal, with chloride the expected byproduct. Chlorite reduction occurs quickly in the pH range of 5 to 7, and complete reduction occurs within 3 to 5 seconds. Excess reduced iron remaining in solution reacts with dissolved oxygen at neutral pH, but under acidic conditions (pH < 6.5) the stability of the soluble iron can create aesthetic (staining) problems if excess iron is used. Special consideration should be given to ferrous iron dosage requirements so that the secondary MCL for iron is not exceeded (Knocke and Iatrou, 1993).

Chlorite can be controlled by PAC at relatively high dosages (10 to 20 mg/L) and low pHs (5.5 to 6.5). Unless PAC is used for other purposes, such as odor control, it requires large doses and is not cost effective. PAC brands can differ in their capacity to reduce chlorite.

GAC can remove chlorite but breakthrough may occur relatively early. The removal of chlorite by GAC appears to be a result of adsorption and chemical reduction (Dixon and Lee, 1991). There is an initial high removal efficiency due to chlorite adsorption. As the adsorptive sites are occupied, chemical reduction on the GAC surface becomes the primary removal mechanism. This results in an initial high removal efficiency. Although chlorite levels exiting the GAC filters are low, the chlorate levels are high, most likely a result of reactions in the GAC filters between chlorite and free chlorine. According to studies, the capacity of GAC beds is low, and if free chlorine and chlorite ion are present in the GAC influent, chlorate ion will form. The most effective way to operate GAC for chlorite reduction and avoid chlorate is to minimize production run times and have no chlorine present in the filter.

## 4.6 Status of Analytical Methods

In addition to the monitoring requirements that apply regardless of the disinfectant used, the DBPR requires that water systems that use chlorine dioxide for disinfection or oxidation must also monitor their system for chlorine dioxide and chlorite.

### 4.6.1 Chlorine Dioxide and Chlorite Analytical Methods

For compliance monitoring for chlorine dioxide, systems must use one of the two methods specified in 40 CFR §141.131(c), including (1) DPD, Standard Method 4500-CLO<sub>2</sub> D, or (2) Amperometric Method II, Standard Method 4500-CLO<sub>2</sub> E. Where approved by the state, systems may also measure residual disinfectant concentrations for chlorine dioxide by using DPD colorimetric test kits.

For compliance monitoring for chlorite, systems must use one of the three methods specified in 40 CFR §141.131(b), including (1) Amperometric Titration, Standard Method 4500-CLO<sub>2</sub> E, (2) Ion Chromatography, EPA Method 300.0, or (3) Ion Chromatography, EPA Method 300.1. The regulations specify that Amperometric Titration may be used for routine daily monitoring of chlorite at the entrance to the distribution system, but that Ion Chromatography must be used for routine, monitoring of chlorate and monthly additional monitoring of chlorate in the distribution system.

Details of these analytical procedures can be found in:

- *Standard Methods for the Examination of Water and Wastewater*, 19<sup>th</sup> Edition, American Public Health Association, 1995.
- *Methods for the Determination of Inorganic Substances in Environmental Samples*. USEPA. 1993. EPA/600/R-93/100.
- *USEPA Method 300.1, Determination of Inorganic Anions in Drinking Water by Ion Chromatography, Revision 1.0*. USEPA. 1997. EPA/600/R-98/118.

Table 4-3 summarizes the analytical methods approved for use for chlorine dioxide and chlorite and provides some background information for each method.

### 4.6.2 Chlorine Dioxide Monitoring for Systems Using Chlorine Dioxide

For chlorine dioxide monitoring, community, non-transient non-community, and transient non-community water systems that use chlorine dioxide for disinfection or oxidation, are required to take daily samples at the entrance to the distribution system. For any daily sample that exceeds the chlorine dioxide MRDL of 0.8 mg/L, the system must take additional samples in the distribution system the following day at the locations specified in the DBPR, in addition to the daily sample required at the entrance to the distribution system.

Additional sampling is to be performed in one of two ways, depending on the disinfectant that is used to maintain a disinfectant residual in the distribution system. If chlorine dioxide or chloramines are used to maintain a disinfectant residual, or if chlorine is used to maintain the residual and there are no disinfection addition points after the entrance to the distribution system (i.e., no booster chlorination), the system must take three samples as close to the first customer as possible, at intervals of at least six hours. If chlorine is used to maintain a disinfectant residual and there are one or more disinfection addition points after the entrance to the distribution system, the system must take one sample at each of the following locations: (1) as close to the first customer as possible, (2) in a location representative of average residence time,



and (3) as close to the end of the distribution system as possible (reflecting maximum residence time in the distribution system). Chlorine dioxide monitoring may not be reduced.

If any daily sample taken at the entrance to the distribution system exceeds the MRDL, and on the following day one (or more) of the three samples taken in the distribution system exceed the MRDL, the system is in violation of the MRDL. The system must take immediate corrective action to lower the level of chlorine dioxide below the MRDL, and must notify the public of the acute violation pursuant to 40 CFR §141.32. The system must also report to the State pursuant to 40 CFR §141.134.

If any two consecutive daily samples taken at the entrance to the distribution system exceed the MRDL, the system is also in violation of the MRDL and must notify the public of the non-acute violation pursuant to 40 CFR §141.32. The system must also report to the State pursuant to 40 CFR §141.134.

### **4.6.3 Chlorite Monitoring for Systems Using Chlorine Dioxide**

For chlorite monitoring, community and non-transient non-community water systems that use chlorine dioxide for disinfection or oxidation are required to take daily samples at the entrance to the distribution system. For any daily sample that exceeds the chlorite MCL of 1.0 mg/L, the system must take additional samples in the distribution system the following day at the locations specified in the DBPR. These additional samples are to be collected at: (1) a location as close to the first customer as possible, (2) a location representative of average residence time, and (3) a location as close to the end of the distribution system as possible (reflecting maximum residence time in the distribution system).

In addition, systems using chlorine dioxide must take a three-sample set each month in the distribution system similar to the three locations required if the chlorite MCL is exceeded in the sample collected at the entrance to the distribution system. Specifically, these three-sample sets are to be collected: (1) in a location near the first customer, (2) in a location representative of average residence time, and (3) at a location reflecting maximum residence time in the distribution system. Any additional routine sampling must be conducted in the same three-sample sets at the specified locations. This monthly sampling requirement may be reduced to quarterly after one year of monitoring where: (1) no individual chlorite sample taken in the distribution system has exceeded the MCL and (2) the system has not been required to conduct follow-up monitoring as a result of a daily sample collected at the entrance to the distribution system. These systems can remain on an annual schedule until either the daily sample or any of the three individual quarterly samples exceed the MCL, at which time, the system must revert to monthly monitoring.

If the arithmetic average of any three-sample set exceeds the chlorite MCL of 1.0 mg/L, the system is in violation of the MCL and must notify the public pursuant to 40 CFR §141.32, in addition to reporting to the State pursuant to 40 CFR §141.134.

## **4.7 Operational Considerations**

As with all disinfectant selections, the primacy agency should be consulted when selecting disinfectants. Certain states have their own operational, maintenance, and monitoring requirements

for the application of chlorine dioxide. California prohibits the use of chlorine dioxide in ground water systems, according to Merkle et al., 1997. Also, in Texas, the Texas Natural Resources Conservation Commission (TNRCC) requires the public water supply to sign a bilateral agreement which outlines a detailed operator qualifications requirement, testing methods, and procedures, monitoring locations, testing frequency and reporting procedures. The chlorine dioxide concentration leaving the water treatment plant must be less than 0.8 mg/L and the chlorite concentration in the distribution system must be less than 1.0 mg/L.

State requirements must be reviewed to determine the cost-effectiveness of utilizing chlorine dioxide as part of the overall water treatment scheme. Analytical testing and reporting requirements may have significant labor and cost impacts.

**Table 4-3. Analytical Methods for Chlorine Dioxide and Related Compounds**

Method	Basis	Interferences	Limits
DPD as Test Kits Colorimetric (SM-4500-ClO <sub>2</sub> G)	Colored oxidation product. Use of color comparator is not recommended. Use instrument detection.	Mn <sub>2</sub> <sup>+</sup> , other Cl <sub>2</sub> , related oxidants.	> 0.1 mg/L
DPD-glycine Method Colorimetric (SM 4500- ClO <sub>2</sub> .D)	Colored product, free Cl <sub>2</sub> is masked with glycine as chloraminacetic acid.	ClO <sub>2</sub> <sup>-</sup> slowly; other oxidants.	> 0.1 mg/L
DPD-FAS Titrimetric method (SM 4500- ClO <sub>2</sub> .D)	DPD color titration with standard FAS until red color is discharged.	Iron, other oxidants.	> 0.1 mg/L
5-Step Amperometric Method 4500-ClO <sub>2</sub> .E	I <sup>-</sup> oxidation; pH control and gas purging steps. Skilled analyst needed.	Suitable for ClO <sub>2</sub> generated solution. Low levels not okay.	~ PQL ClO <sub>2</sub> : 0.1-0.05 mg/L; ClO <sub>3</sub> <sup>-</sup> at 0.5 mg/L
Ion Chromatography (EPA Method 300.0 or 300.1) Conductivity	Must use AS9 column, ext. standards & suppression.	No other oxidants. Chloramines, ClO <sub>2</sub> <sup>-</sup> , OCl <sup>-</sup> & HOCl undetectable.	~ 0.05 mg/L
Two-step Amperometric Method 4500-ClO <sub>2</sub> .E	I <sup>-</sup> Oxidation; pH control. Amendable to operator-based dosage control. Practical method.	Cu <sub>2</sub> <sup>+</sup> , Mn <sub>2</sub> <sup>+</sup> , NO <sub>2</sub> <sup>-</sup> Accounts for free Cl <sub>2</sub> , NH <sub>2</sub> Cl, ClO <sub>2</sub> <sup>-</sup> species.	> 0.1 mg/L, not ClO <sub>3</sub> <sup>-</sup>

Source: Gates, 1998.

Notes: SM = Standard Methods

### 4.7.1 Process Considerations

The basic components of chlorine dioxide generation systems include:

- Aqueous hypochlorite solution storage and feed system;
- Sodium chlorite storage and feed system;
- Acid storage and feed system (for Direct-Acidification generators);
- Chlorine storage and feed system;
- Chlorine dioxide generator; and
- Chlorine dioxide feed piping and dispersion equipment.

Sodium chlorite storage and feed systems are basically liquid systems that consist of a storage tank(s) and solution feed pumps. Outside storage of 25 percent solutions (or greater) of sodium chlorite is not recommended in cold climates since stratification may occur below 4°C (40°F). Any ice formation may also damage the storage tanks. In some cases, storage might be separated into bulk tanks and smaller operational or day tanks that are filled periodically. Storage of dark drums for long periods in hot climates should be avoided since sodium chlorite decomposition will occur. In the storage area, light fixtures, switches, wiring, and conduit runs should be located to avoid the risk of sodium chlorite spilling on them.

## 4.7.2 Generator Operation

A manual chlorine dioxide feed system may be used where the chlorine dioxide dose remains fairly constant. The reagent chemicals are manually set for the desired chlorine dioxide capacity at a ratio of chemicals optimized for maximum chlorine dioxide yield. Some generating systems can produce 95 percent pure chlorine dioxide solutions at full design capacity, but purity can vary when the feed rate is changed. Turndown capacity may be limited by precision of the flow metering devices, typically 20 percent of rate capacity. Purity can vary when the feed rate is changed significantly. Feed water alkalinity, operating conditions, and pH also can affect yield. The ratio of reagent chemicals should be routinely adjusted for optimum operation. Chlorine dioxide generators can be provided with automated control to provide modulation of chlorine dioxide feed rates based upon changes in flow (flow paced) and chlorine dioxide demand (residual control). The automatic modulation of the generators to meet a demand setpoint varies with manufacturer. Generally, vacuum and combination systems are limited by the hydraulic requirements of the venturi and the optimum reaction conditions for chlorine dioxide generation. A chemical metering pump or injector system is then used with a batch production system to control the applied dose of chlorine dioxide.

## 4.7.3 Feed Chemicals

Chlorine dioxide is generated when sodium chlorite is either oxidized or acidified, or both, under controlled pH and temperature conditions. Commonly, solutions of 25 percent active sodium chlorite or less are used in chlorine dioxide generators. The major safety concern for solutions of sodium chlorite is the unintentional and uncontrollable release of high levels of chlorine dioxide. Such levels may approach detonation or conflagration concentrations by accidental acidification.

The feedstock acid used by some of the generators is only one source of accidental chemical acidification. Accidental mixing with large amounts of any reducing agent or oxidizable material (such as powdered activated carbon or flammable solvents) also represents a significant hazard. The AWWA Standard B303-95 (a) includes an outline of some of these materials (AWWA, 1995).

Another concern when handling and storing sodium chlorite solutions is crystallization, which occurs as a result of lower temperatures and/or higher concentrations. Crystallization will plug pipelines, valves, and other equipment. Sodium chlorite solution should not be allowed to evaporate to a powder. If dried, this product becomes a fire hazard and can ignite in contact with combustible materials. A sodium chlorite fire may result in a steam explosion if too much water and inappropriate fire-fighting techniques are used to quench such a fire. As the temperature of burning sodium chlorite is around 2200°C, water quickly turns to steam. Because thermal breakdown products of sodium chlorite at high temperatures include molecular oxygen, appropriate techniques are required to correctly extinguish closed containers or large amounts of dry material that has been ignited.

Stratification of sodium chlorite in holding tanks may also occur and would influence the chlorine dioxide yield. If stratification occurs in the bulk tank, sodium chlorite changes from high density to

low density as it is fed. The density will continue to change until the material is re-mixed. In stratified tanks, excess chlorite would be fed to the generator since the bottom of the tank will have denser material, and this material would have more chlorite than required. Similarly, the bulk tank would later discharge too little chlorite.

Although infrequent, such stratification is not readily apparent and may likely remain unnoticed by operations unless the generator performance is evaluated frequently. If stratification or crystallization occurs in bulk delivery trucks, the entire content should be warmed prior to delivery so that the sodium chlorite is re-mixed. Operators should be aware of the possibility of stratification and crystallization during delivery conditions.

Sodium chlorite is commercially available as a 38 percent or 25 percent solution. Chemical and physical properties are given in Table 4-4.

**Table 4-4. Properties of Sodium Chlorite as Commercially Available**

	38% Solution*	25% Solution*
Sodium Chlorite, (%) NaClO <sub>2</sub>	38	25
Sodium Chloride, (%) NaCl	1.5-7.5	1-4.5
Inert Ingredients, mixture of other sodium salts (%)	3-4	3-4
Water (%)	55-61	68-74
Appearance	Slightly cloudy, pale yellow	Clear, pale yellow
Density @ 35°C (lb/gal), typical	11.4	10.1
Crystallization Point (°C)	25	-7

\* Source: Vulcan Chemicals

For systems handling the 38 percent solution, storage tanks, piping and pumps will require a heated enclosure, or heat tracing and insulation. The 25 percent solution may not require any special protection except in cold climates.

The ideal production of 1.0 pound of chlorine dioxide requires 0.5 pounds of chlorine and 1.34 pounds of pure sodium chlorite. Chlorine gas is available as a nearly 100 percent pure chemical on a weight basis. Gas flow metering devices are typically limited to +/- 5 percent accuracy at full rated capacity. For example, a 100 pound per day flow tube would allow between 20 and 30 pounds of chlorine to flow if set at 25 pounds per day (i.e., 25 +/- 5 percent of maximum flow capacity). Sodium chlorite is supplied commercially as a pre-mixed aqueous solution of various strengths. The 25 percent solution is the most commonly used grade for potable water treatment.

Pure chlorine dioxide solutions (very dark amber and oily in appearance) are very dangerous and are likely to detonate if exposed to oxidizable materials or vapors, or even to bright lights. They are extremely uncommon except perhaps in very specific laboratory setup systems using concentrated sodium chlorite and concentrated acid mixtures. Such laboratory generation methods are not

recommended for the uninitiated laboratory analyst or operator. Inexperienced personnel should not mix strong acid and strong sodium chlorite solutions together unless they are familiar with the purgeable extraction methods for sodium chlorite and have a safely designed setup under a fume hood.

## 4.8 Summary

### 4.8.1 Advantages and Disadvantages of Chlorine Dioxide Use

The following list highlights selected advantages and disadvantages of using chlorine dioxide as a disinfection method for drinking water (Masschelein, 1992; DeMers and Renner, 1992, Gallagher et al., 1994). Because of the wide variation of system size, water quality, and dosages applied, some of these advantages and disadvantages may not apply to a particular system.

#### Advantages

- Chlorine dioxide is more effective than chlorine and chloramines for inactivation of viruses, *Cryptosporidium*, and *Giardia*.
- Chlorine dioxide oxidizes iron, manganese, and sulfides.
- Chlorine dioxide may enhance the clarification process.
- Taste and odors resulting from algae and decaying vegetation, as well as phenolic compounds, are controlled by chlorine dioxide.
- Under proper generation conditions (i.e., no excess chlorine), halogen-substituted DBPs are not formed.
- Chlorine dioxide is easy to generate.
- Biocidal properties are not influenced by pH.
- Chlorine dioxide provides residuals.

#### Disadvantages

- The chlorine dioxide process forms the specific byproducts chlorite and chlorate.
- Generator efficiency and optimization difficulty can cause excess chlorine to be fed at the application point, which can potentially form halogen-substitute DBPs.
- Costs associated with training, sampling, and laboratory testing for chlorite and chlorate are high.
- Equipment is typically rented, and the cost of the sodium chlorite is high.
- Measuring chlorine dioxide gas is explosive, so it must be generated on-site.
- Chlorine dioxide decomposes in sunlight.
- Chlorine dioxide must be made on-site.
- Can lead to production noxious odors in some systems.

## 4.8.2 Summary Table

Table 4-5 summarizes considerations and descriptions for chlorine dioxide use.

**Table 4-5. Summary for Chlorine Dioxide**

Consideration	Description
Generation	Chlorine dioxide must be generated on-site. In most potable water applications, chlorine dioxide is generated as needed and directly added or injected into a diluting stream. Generators are available that utilize sodium chlorite and a variety of feedstocks such as Cl <sub>2</sub> gas, sodium hypochlorite, and sulfuric or hydrochloric acid. Small samples of generated solutions, up to 1 percent (10 g/L) chlorine dioxide can be safely stored if the solution is protected from light, chilled (<5°C), and has no unventilated headspace.
Primary Uses	Chlorine dioxide is utilized as a primary or secondary disinfectant, for taste and odor control, TTHM/HAA reduction, Fe and Mn control, color removal, sulfide and phenol destruction, and Zebra mussel control.
Inactivation Efficiency	Chlorine dioxide rapidly inactivates most microorganisms over a wide pH range. It is more effective than chlorine (for pathogens other than viruses) and is not pH dependent between pH 5-10, but is less effective than ozone.
Byproducts Formation	When added to water, chlorine dioxide reacts with many organic and inorganic compounds. The reactions produce chlorite and chlorate as endproducts (compounds that are suspected of causing hemolytic anemia and other health effects). Chlorate ion is formed predominantly in downstream reactions between residual chlorite and free chlorine when used as the distribution system disinfectant. Chlorine dioxide does not produce THMs. The use of chlorine dioxide aids in reducing the formation of TTHMs and HAAs by oxidizing precursors, and by allowing the point of chlorination to be moved farther downstream in the plant after coagulation, sedimentation, and filtration have reduced the quantity of NOM.
Point of Application	In conventional treatment plants, chlorine dioxide used for oxidation is fed either in the raw water, in the sedimentation basins, or following sedimentation. To limit the oxidant demand, and therefore chlorine dioxide dose and the formation of chlorite, it is common to add chlorine dioxide following sedimentation. Concerns about possible taste and odor complaints have limited the use of chlorine dioxide to provide a disinfectant residual in the distribution system. Consequently, public water suppliers that are considering the use of chlorine dioxide for oxidation and primary disinfectant applications may want to consider chloramines for secondary disinfection.
Special Considerations	An oxidant demand study should be completed to determine an approximate chlorine dioxide dosage to obtain the required CT value as a disinfectant. In addition to the toxic effects of chlorine, chlorine dioxide gas is explosive at levels > 10% in air. The chlorine dioxide dosage cannot exceed 1.4 mg/L to limit the total combined concentration of ClO <sub>2</sub> , ClO <sub>2</sub> <sup>-</sup> , ClO <sub>3</sub> <sup>-</sup> , to a maximum of 1.0 mg/L. Under the proposed DBP regulations, the MRDL for chlorine dioxide is 0.8 mg/L and the MCL for chlorite is 1.0 mg/L. Regulations concerning the use of chlorine dioxide vary from state-to-state.

## 4.9 References

1. Aieta, E., and J.D.Berg. 1986. "A Review of Chlorine Dioxide in Drinking Water Treatment." *J. AWWA*. 78(6):62-72.
2. Aieta, E.M., P.V. Roberts, and M. Hernandez. 1984. "Determination of Chlorine Dioxide, Chlorine and Chlorate in Water." *J. AWWA*. 76(1):64-70.
3. Alvarez, M.E. and R.T. O'Brien. 1982. "Mechanism of Inactivation of Poliovirus by Chlorine Dioxide and Iodine." *Appl. Envir. Microbiol.* 44:1064.
4. AWWA (American Water Works Association). 1995. AWWA Standard B303-95: Sodium Chlorite.
5. AWWA. 1991. *Guidance Manual for Compliance with the Filtration and Disinfection Requirements for Public Water Systems Using Surface Water Sources*.
6. AWWA. 1990. *Water Quality and Treatment*, fourth edition. McGraw-Hill, Inc., New York, NY.
7. Bedulivich, T.S., M.N. Svetlakova, and N.N. Trakhtman. 1954. "Use of Chlorine Dioxide in Purification of Water." *Chemical Abstracts*. 48:2953.
8. Bernarde, M.A., et al. 1967a. "Kinetics and Mechanism of Bacterial Disinfection by Chlorine Dioxide." *J. Appl. Microbiol.* 15(2):257.
9. Bernarde, M.A., W.B. Snow, and V.P. Olivieri. 1967b. "Chlorine Dioxide Disinfection Temperature Effects." *J. Appl. Bacteriol.* 30(1):159.
10. Chen, Y.S.R., O.J. Sproul, and A.J. Rubin. 1985. "Inactivation of *Naegleria gruberi* Cysts by Chlorine Dioxide." *Water Res.* 19(6):783.
11. Chen, Y.S.R., O.J. Sproul, and A.J. Rubin. 1984. "Inactivation of *Naegleria Gruberi* cysts by Chlorine Dioxide." EPA Grant R808150-02-0, Department of Civil Engineering, Ohio State University.
12. *CRC Handbook of Chemistry and Physics*. 1990. D.L. Lide (editor), Seventy-first edition, CRC Press, Boca Raton, FL.
13. Cronier, S., et al. 1978. *Water Chlorination Environmental Impact and Health Effects*, Vol. 2. R. L. Jolley, et al. (editors) Ann Arbor Science Publishers, Inc. Ann Arbor, MI.
14. Demers, L.D., and R. Renner. 1992. *Alternative Disinfectant Technologies for Small Drinking Water Systems*. AWWARF, Denver, CO.



15. Dixon, K.L. and R.G. Lee. 1991. "Disinfection By-Products Control: A Survey of American System Treatment Plants." Presented at AWWA Conference, Philadelphia, PA.
16. Emmenegger, F. and G. Gordon. 1967. "The Rapid Interaction Between Sodium Chlorite and Dissolved Chlorine." *Inorg. Chem.* 6(3):633.
17. Finch, G.R., L.R. Liyanage, M. Belosevic, and L.L. Gyürek. 1997. "Effects of Chlorine Dioxide Preconditioning on Inactivation of *Cryptosporidium* by Free Chlorine and Monochloramine: Process Design Requirements." Proceedings 1996 Water Quality Technology Conference; Part II. Boston, MA.
18. Finch, G.R., L.R. Liyanage, and M. Belosevic. 1995. "Effect of Disinfectants and *Cryptosporidium* and *Giardia*." Third International Symposium on Chlorine Dioxide: Drinking Water, Process Water, and Wastewater Issues.
19. Gallagher, D.L., R.C. Hoehn, A.M. Dietrich. 1994. *Sources, Occurrence, and Control of Chlorine Dioxide By-Product Residuals in Drinking Water*. AWWARF, Denver, CO.
20. Gates, D.J. 1998. *The Chlorine Dioxide Handbook; Water Disinfection Series*. AWWA Publishing, Denver, CO.
21. Gates, D.J. 1989. "Chlorine Dioxide Generation Technology and Mythology." Conference proceedings, Advances in Water Analysis and Treatment, AWWA, Philadelphia, PA.
22. Ghandbari, E. H., et al. 1983. "Reactions of Chlorine and Chlorine Dioxide with Free Fatty Acids, Fatty Acid Esters, and Triglycerides." *Water Chlorination: Environmental Impact and Health Effects*, R. L. Jolley, et al. (editors), Lewis, Chelsea, MI.
23. Gordon, G., G.L. Emmert, and B. Bubnis. 1995. "Bromate Ion Formation in Water When Chlorine Dioxide is Photolyzed in the Presence of Bromide Ion." Conference proceedings, AWWA Water Quality Technology Conference, New Orleans, LA.
24. Gordon, G., et al. 1990. "Minimizing Chlorite Ion and Chlorate Ion in Water Treated with Chlorine Dioxide." *J. AWWA*. 82(4): 160-165.
25. Gordon, G., W.J. Cooper, R.G. Rice, and G.E. Pacey. 1987. *Disinfectant Residual Measurement Methods*, AWWARF, Denver, CO.
26. Gordon, G., R.G. Kieffer, and D.H. Rosenblatt. 1972. "The Chemistry of Chlorine Dioxide." *Progress in Organic Chemistry*, vol. 15. S.J. Lippaer (editor). Wiley Interscience, New York, NY.
27. Great Lakes Upper Mississippi River Board of State Public Health (GLUMRB) and Environmental Managers. 1992. *Recommended Standards for Water Works*, Health Research Inc., Albany, NY.

28. Gregory, D. and K. Carlson. 1998. "Applicability of Chlorine Dioxide for *Cryptosporidium* Inactivation." Proceedings 1998 Water Quality Technology Conference, San Diego, CA.
29. Griese, M.H., K. Hauser, M. Berkemeier, and G. Gordon. 1991. "Using Reducing Agents to Eliminate Chlorine Dioxide and Chlorite Ion Residuals in Drinking Water." *J. AWWA*. 83(5):56.
30. Hoehn, R.C. 1992. "Chlorine Dioxide Use in Water Treatment: Key Issues." Conference proceedings, Chlorine Dioxide: Drinking Water Issues: Second International Symposium. Houston, TX.
31. Hoehn, R.C., A.A. Rosenblatt, and D.J. Gates. 1996. "Considerations for Chlorine Dioxide Treatment of Drinking Water." Conference proceedings, AWWA Water Quality Technology Conference, Boston, MA.
32. Hofman, R., R.C. Andrews, and Q. Ye. 1997. "Chlorite Formation When Disinfecting Drinking Water to *Giardia* Inactivation Requirements Using Chlorine Dioxide." Conference proceedings, ASCE/CSCE Conference, Edmonton, Alberta, July.
33. Knocke, W.R. and A. Iatrou. 1993. *Chlorite Ion Reduction by Ferrous Ion Addition*. AWWARF, Denver, CO.
34. Korich, D.G., et al. 1990. "Effects of Ozone, Chlorine Dioxide, Chlorine, and Monochloramine on *Cryptosporidium parvum* oocyst Viability." *Appl. Environ. Microbiol.* 56:1423-1428.
35. LeChevallier, M.W., et al. 1997. "Chlorine Dioxide for Control of *Cryptosporidium* and Disinfection Byproducts." Conference proceedings, 1996 AWWA Water Quality Technology Conference Part II, Boston, Massachusetts.
36. LeChevallier, M.W., et al. 1996. "Chlorine Dioxide for Control of *Cryptosporidium* and Disinfection Byproducts." Conference proceedings, AWWA Water Quality Technology Conference, Boston, Massachusetts.
37. Liyanage, L.R.J, et al. 1997. "Effects of Aqueous Chlorine and Oxychlorine Compounds on *Cryptosporidium Parvum* Oocysts." *Environ. Sci. & Tech.* 31(7): 1992-1994
38. Masschelein, W.J. 1992. "Unit Processes in Drinking Water Treatment." Marcel Decker D.C., New York, Brussels, Hong Kong.
39. Merkle, J.C. and C.B. Reeverts. 1997. "Ground Water Treatment: What Are the States Doing Now?" AWWARF, Denver, CO.
40. Noack, M.G. and R.L. Doerr. 1977. "Reactions of Chlorine, Chlorine Dioxide and Mixtures of Humic Acid: An Interim Report." Conference proceedings, Second Conference on the Environmental Impact of Water Chlorination. R.L. Jolley, H. Gorchev, and D. Heyward (editors), Gatlinburg, TN.

41. Noss, C.I., W.H. Dennis, V.P. Olivieri. 1983. "Reactivity of Chlorine Dioxide with Nucleic Acids and Proteins." *Water Chlorination: Environmental Impact and Health Effects*. R. L. Jolley, et al. (editors), Lewis Publishers, Chelsea, MI.
42. Olivieri, V.P., et al. 1985. "Mode of Action of Chlorine Dioxide on Selected Viruses." *Water Chlorination: Environmental Impact and Health Effects*. R. L. Jolley, et al. (editors), Lewis, Chelsea, MI.
43. Olivieri, V.P., et al. 1984. Stability and Effectiveness of Chlorine Disinfectants in Water Distribution Systems. USEPA, Cincinnati, OH.
44. Peeters, J. E. et al. 1989. "Effect of Disinfection of Drinking Water with Ozone or Chlorine Dioxide on Survival of *Cryptosporidium parvum* oocysts." *Appl. Environ. Microbiol.* 55:1519-1522.
45. Pitochelli, A. 1995. "Chlorine Dioxide Generation Chemistry." Conference proceedings, Third International Symposium, Chlorine Dioxide: Drinking Water, Process Water, and Wastewater Issues. New Orleans, LA.
46. Ransome, M.E., T.N. Whitmore, and E.G. Carrington. 1993. "Effect of Disinfectants on the Viability of *Cryptosporidium parvum* Oocysts." *Water Supply*. 11(1):103-117.
47. Rav-Acha, C., A. Serri, E. Choshen, B. Limoni. 1984. "Disinfection of Drinking Water Rich in Bromide with Chlorine and Chlorine Dioxide, While Minimizing the Formation of Undesirable Byproducts." *Wat. Sci. Technol.* 17:611.
48. Richardson, S.D. et al. 1994. "Multispectral Identification of ClO<sub>2</sub> Disinfection Byproducts in Drinking Water." *Environ. Sci. & Technol.* 28(4):592-599.
49. Ridenour, G.M. and E.H. Armbruster. 1949. "Bactericidal Effects of Chlorine Dioxide." *J. AWWA*. 41:537.
50. Ridenour, G. M. and R.S. Ingols. 1947. "Bactericidal Properties of Chlorine Dioxide." *J. AWWA*. 39.
51. Ridenour, G.M., and R.S. Ingols. 1946. "Inactivation of Poliomyelitis Virus by Free Chlorine." *Amer. Public Health*. 36:639.
52. Ridenour, G.M., and R.S. Ingols, and E.H. Armbruster. 1949. "Sporicidal Properties of Chlorine Dioxide." *Water & Sewage Works*. 96(8):279.
53. Roberts, P.V., E.M. Aieta, J.D. Berg, and B.M. Chow. 1980. "Chlorine Dioxide for Wastewater Disinfection: A Feasibility Evaluation." Stanford University Technical Report 251. October.

54. Roller, S. D. et al. 1980. "Mode of Bacterial Inactivation by Chlorine Dioxide." *Water Res.* 14:635.
55. Singer, P.C. 1992. "Formation and Characterization of Disinfection Byproducts." Presented at the First International Conference on the Safety of Water Disinfection: Balancing Chemical and Microbial Risks.
56. Singer, P.C., and W.K. O'Neil. 1987. "Technical Note: The Formation of Chlorate from the Reaction of Chlorine and Chlorite in Dilute Aqueous Solution." *J. AWWA.* 79(11):75.
57. Smith, J. E., and J.L. McVey. 1973. "Virus Inactivation by Chlorine Dioxide and Its Application to Storm Water Overflow." Proceeding, ACS annual meeting. 13(2):177.
58. Sobsey, M. 1988. "Detection and Chlorine Disinfection of Hepatitis A in Water." CR-813-024, EPA Quarterly Report, December.
59. Sproul, O. J. et al. 1983. "Comparison of Chlorine and Chlorine Dioxide for Inactivation of Amoebic Cyst." *Envir. Technol. Letters.* 4:335.
60. Thompson, A.L. 1989. "Practical Considerations for Application of Chlorine Dioxide in Municipal Water Systems." Conference proceedings,, Chlorine Dioxide Workshop. AWWARF, CMA, EPA. Denver, CO.
61. Trakhtman, N.N. 1949. "Chlorine Dioxide in Water Disinfection." *Chemical Abstracts.* 43:1508.
62. USEPA (U.S. Environmental Protection Agency). 1983. "Trihalomethanes in Drinking Water: Sampling, Analysis, Monitoring, and Compliance." EPA 570/9-83-002, August.
63. USEPA. 1979. "Effect of Particulates on Disinfection of Enteroviruses and Coliform Bacteria in Water by Chlorine Dioxide." EPA-600/2-79-054.
64. USEPA 1978. "Effect of Particulates on Inactivation of Enteroviruses in Water by Chlorine Dioxide." EPA-600/9-79-018, Cincinnati, OH.
65. Werdehoff, K.S, and P.C. Singer. 1987. "Chlorine Dioxide Effects on THMFP, TOXFP and the Formation of Inorganic By-Products." *J. AWWA.* 79(9):107.

THIS PAGE INTENTIONALLY LEFT BLANK

<b>4.</b>	<b>CHLORINE DIOXIDE .....</b>	<b>4-1</b>
4.1	CHLORINE DIOXIDE CHEMISTRY .....	4-1
4.1.1	Oxidation Potential.....	4-1
4.2	GENERATION.....	4-2
4.2.1	Introduction.....	4-2
4.2.2	Chlorine Dioxide Purity.....	4-3
4.2.3	Methods of Generating Chlorine Dioxide.....	4-4
4.1.4	Generator Design .....	4-9
4.1.5	Chemical Feed Systems.....	4-11
4.1.6	Generator Power Requirements.....	4-13
4.3	PRIMARY USES AND POINTS OF APPLICATION FOR CHLORINE DIOXIDE.....	4-13
4.3.1	Disinfection.....	4-13
4.3.2	Taste and Odor Control .....	4-14
4.3.3	Oxidation of Iron and Manganese .....	4-14
4.4	PATHOGEN INACTIVATION AND DISINFECTION EFFICACY.....	4-15
4.4.1	Inactivation Mechanisms .....	4-15
4.4.2	Environmental Effects .....	4-15
4.4.3	Disinfection Efficacy .....	4-17
4.5	CHLORINE DIOXIDE DISINFECTION BYPRODUCTS.....	4-22
4.5.1	Production of Chlorite and Chlorate.....	4-22
4.5.2	Organic DBPs Produced by Chlorine Dioxide.....	4-25
4.5.3	Chlorine Dioxide DBP Control Strategies .....	4-25
4.6	STATUS OF ANALYTICAL METHODS.....	4-26
4.6.1	Chlorine Dioxide and Chlorite Analytical Methods .....	4-27
4.6.2	Chlorine Dioxide Monitoring for Systems Using Chlorine Dioxide .....	4-27
4.6.3	Chlorite Monitoring for Systems Using Chlorine Dioxide .....	4-28
4.7	OPERATIONAL CONSIDERATIONS.....	4-28
4.7.1	Process Considerations .....	4-30
4.7.2	Generator Operation.....	4-31
4.7.3	Feed Chemicals .....	4-31
4.8	SUMMARY .....	4-33
4.8.1	Advantages and Disadvantages of Chlorine Dioxide Use.....	4-33
4.8.2	Summary Table .....	4-34
4.9	REFERENCES .....	4-35

Table 4-1.	Commercial Chlorine Dioxide Generators.....	4-5
Table 4-2.	Surface Water Chlorine Dioxide Demand Study Results.....	4-14
Table 4-3.	Analytical Methods for Chlorine Dioxide and Related Compounds.....	4-30
Table 4-4.	Properties of Sodium Chlorite as Commercially Available.....	4-32
Table 4-5.	Summary for Chlorine Dioxide .....	4-34

Figure 4-1.	Conventional Chlorine Dioxide Generator When Using Chlorine-Chlorite Method.....	4-7
Figure 4-2.	Chlorine Dioxide Generation Using Recycled Aqueous Chlorine Method.....	4-8
Figure 4-3.	Effect of Temperature on <i>N. Gruberi</i> Cyst Inactivation at pH 7 .....	4-17
Figure 4-4.	Comparison of Germicidal Efficiency of Chlorine Dioxide and Chlorine.....	4-19
Figure 4-5.	CT Values for Inactivation of <i>Giardia</i> Cysts by Chlorine Dioxide.....	4-21
Figure 4-6.	CT Values for Inactivation of Viruses by Chlorine Dioxide.....	4-22
Figure 4-7.	<i>C. parvum</i> Inactivation by Chlorine Dioxide at 20°C.....	4-23
Figure 4-8.	<i>C. parvum</i> Inactivation by Chlorine Dioxide at 10°C.....	4-23

# Toxicological Effects of Chlorite in the Mouse

by Gary S. Moore\* and Edward J. Calabrese\*

When exposed to a maximum level of 100 ppm chlorine dioxide in their drinking water, neither A/J or C57L/J mice exhibited any hematologic changes. Chlorite exposure under similar conditions produced increases for red blood cells in osmotic fragility, mean corpuscular volume, and glucose-6-phosphate dehydrogenase activity for both strains. Chlorite exposure of pregnant A/J mice resulted in a significant decrease in the weight of pups at weaning and a lower average birth to weaning growth rate. Mice exposed to as much as 100 ppm sodium chlorite (NaClO<sub>2</sub>) in their drinking water for up to 120 days failed to demonstrate any histopathological changes in kidney structure.

## Introduction

The primary method of water disinfection in the United States employs chlorine. Studies, however, have shown that chlorine interacts with organics in the water to form trihalomethanes (1,2). One of the trihalomethanes is chloroform, which has been found to be carcinogenic in rats (3). It has been postulated that chlorinated water supplies may increase the risk of cancer to humans (4-7); such compounds are formed to a lesser extent in water disinfected with chlorine dioxide (8). While toxicological studies have revealed limited physiologic effects from chlorine dioxide, concern has now been directed towards the end products of such disinfection which include chlorate and chlorite (7,8). Chlorites appear in concentrations of up to 50% of the chlorine dioxide demand where chlorine dioxide is used for disinfection (8). Blood destruction, nephritis, and methemoglobinemia have developed in humans after acute poisoning with large doses of chlorate (9,10). It was suggested that in chronic poisoning from chlorate, uremia, anemia, and nephritis might develop. Chlorite is thought to be a more potent oxidant stressor to blood than chlorate (11). Heffernan (12,13) reported that chlorite belonged to a class of oxidant compounds that stimulate the

reduced glutathione (GSH) levels and the development of hemolytic anemia in animal models.

In attempting to establish minimal health effect levels of oxidants (chlorine dioxide and chlorite) on erythrocytes, it is important to consider the effects of such stressors on potential high risk groups. A large group that falls into this category are persons with lowered G6PD (glucose-6-phosphate dehydrogenase) activity. G6PD-deficient cells have a reduced ability to produce NADPH via the pentose phosphate pathway (PPP), and consequently less GSH is formed. Since GSH is the primary mechanism of defense of the red blood cell against oxidant stress, then persons with deficient G6PD levels have a lowered capacity for protection against oxidants (14, 15) and virtually 100 million males throughout the world belong in this category (14). Among the studies reported here are those designed to evaluate the effects of chlorine dioxide and chlorite on erythrocytes of mouse strains with differential G6PD activity (i.e., the A/J strain has three times the activity of the C57L/J strain).

Another potential high risk group would likely include newborns. The potential effects of chlorite on human newborns may be exaggerated because: (1) infants consume nearly three times as much liquid per unit of body weight than adults (16); (2) infants are born with hemoglobin F (fetal hemoglobin), a form that is readily oxidizable to methemoglobin (17); (3) infants have a lower capacity than adults to reduce methemoglobin enzymatically to

\*Division of Environmental Health, School of Public Health, University of Massachusetts, Amherst, Massachusetts 01003.

hemoglobin (18); (4) newborn infants are characteristically low in vitamin E (18), an important antioxidant compound, because there is little placental transfer of vitamin E.

There is also evidence that the fetus may be at increased risk to oxidant stressors. Shuval and Gruener (19) demonstrated that nitrites can be transferred to the fetus *in utero* causing an elevation of MetHb in fetal blood. When administered in drinking water to pregnant rats, 2000–3000 mg/l. of NaNO<sub>2</sub> resulted in a decreased litter size, increased mortality of pups in the first three weeks and a lagging of growth rate despite having equal birth-weight to controls.

Sodium chlorate has been shown to produce methemoglobin *in vitro* and *in vivo* when administered orally (9,10,20). Oral acute doses of sodium chlorate have resulted in hemolysis, nephritis, methemoglobinemia, and death in man and various species of test animals (9). Since previous studies have shown chlorate to cause renal damage, it was hypothesized that chlorite, because of its more potent oxidant capabilities, may also be potentially harmful to the kidney.

In order to test the above hypotheses, a number of experiments were performed on laboratory animals. The experiments were designed to measure the effects of orally administered chlorite on blood characteristics, kidney structure, as well as the fertility, and the growth rate, mortality and development of newborns.

## Methods

### Animal Care

Two strains of mice, with "normal" (A/J) and low (C57L/J) levels of G6PD activity, were obtained from the Jackson Laboratory, Bar Harbor, Maine. The mice were individually housed in stainless steel cages equipped with constant feed food hoppers and 50 ml calibrated watering devices. The cages were kept under controlled conditions of 12 cycles of light and dark (9 A.M. - 9 P.M. light, 9 P.M. - 9 A.M. dark), and a temperature of  $74 \pm 2^\circ\text{F}$ . Animals were held at these conditions for a one-week period after receipt in order to assess their health and allow for acclimation. Animals were randomly allocated to each of the treatment categories, according to a random scheduling of treatments. Treatment periods of 12 hr occurred during the dark cycle in order to minimize decomposition of ClO<sub>2</sub> by light and to coincide with the nocturnal activity period of the mice.

The watering devices were filled with the appropriate treatment solutions and a reading taken of the volume both before and after the treatment

period. The bottles were removed at the end of this period, and no other water provided until the next treatment period. Average daily consumption of liquid was computed for each mouse, and an overall average computed for each treatment category.

Mice were fed *ad libitum* a balanced rodent diet (Purina Rodent Chow) composed of not less than 23% crude protein, 4.5% crude fat, 6.0% crude fiber, 8.0% ash, and 2.5% minerals.

## Experimental Procedures

**Complete Blood Count (CBC).** The Royco Cellcrit IV Hematology System, consisting of Model 920-A cell counter, Model 720-A hemoglobinometer and Model 365-A diluter, was used to determine red blood cell count (RBC), hematocrit (HCT), white blood count (WBC) and hemoglobin concentration (HBG). Mean corpuscular volume (MCV), mean corpuscular hemoglobin (MCH) and mean corpuscular hemoglobin concentration (MCHC) were then computed from these data.

Quality assurance of equipment performance was checked on a daily basis by means of commercial standards, and equipment performance was measured by comparison of automated and manual hematocrits of the same blood sample.

**Reticulocyte Count.** Staining of reticulocytes was accomplished according to the procedure outlined by Seiverd (21). A 1% physiological saline solution of Brilliant Cresyl Blue was mixed with an equal quantity of whole blood and allowed to stand for 20–30 min. The contents of the tube were then remixed and a smear made. The smear was observed under oil immersion and a total of 500 cells counted. The reticulocytes were expressed as a percentage of the total number of cells counted.

**Glucose-6-Phosphate Dehydrogenase Assay (G6PD).** G6PD activity was determined by a colorimetric procedure using Calbiochem (10933 N. Torrey Pines Rd. LaJolla, Calif. 92037) G6PD reagents and a Perkin-Elmer Coleman 55 spectrophotometer equipped with a flow-through temperature-controlled cell, a Coleman 5–100 enzyme calculator, and a Coleman 47 B.C.D. printer. The G6PD activity was calculated in terms of International Units (I.U.) per gram of hemoglobin in whole blood hemolysate.

**Osmotic Fragility (Automated).** Osmotic fragility was determined using the American Optical Fragilograph (Clinical Instruments Co., Dudley, MA 01570). A 10  $\mu\text{l}$  portion of whole blood was diluted in 7.5 ml of 0.68% isotonic buffered saline (Isoton II diluted to obtain 0.68%), yielding a 1:750 dilution. The instrument was calibrated with 1.5 ml of the prepared cell suspension, added to a cuvette, and the osmotic fragility determined.



**Glutathione (GSH) Assay.** Reduced glutathione was determined by using Glutathione and Erythrozyme Assay (from Princeton Biomedix Inc., Princeton, NJ) using a reagent solution containing 5,5-dithiobis(2-nitrobenzoic acid) (DTNB) which reacts with glutathione to form a highly colored yellow ion.

## Statistical Analysis

Analysis was performed by using the BMDP2V and SPSS ONEWAY (22) programs. The two-way ANOVA table was produced by the BMDP program with the three previously mentioned hypotheses either accepted or rejected, based upon the  $p$  values of the  $F$  test ( $p = 0.05$ ). If a hypothesis was rejected, contrasts were constructed and with separated variances computed with accompanying  $p$  values. These contrasts were run on the SPSS ONEWAY program (22). The Bartlett's and Cochran's tests for equal variances were also computed by using the SPSS ONEWAY program.

## Experimental Design

**Effect of Chlorite on Chlorine Dioxide on Blood Characteristics.** Twenty A/J and 20 C57L/J mice were each divided into two groups of 10 mice with each strain being exposed to 0.0 ppm (10 mice) and 100 ppm (10 mice) chlorine dioxide in their drinking water for 30 days. The animals were lightly etherized and then decapitated by means of a guillotine. The blood was collected into 100  $\mu$ l of 0.6% sodium heparin (Sigma) prior to analysis.

Both A/J ( $N = 63$ ) and C57L/J ( $N = 59$ ) mice were each divided into four groups and exposed to sodium chlorite at 0.0, 1.0, 10.0 and 100.0 ppm in their drinking water for 30 days (Table 1). At the end of the exposure period, blood was collected and analyzed as previously indicated. In addition to measuring the effects of several blood parameters including GSH levels, the weight change over 30 days and the average volume of water consumed per day was determined for each animal.

**Effect on Conception Rate and Litters of A/J Strain Mice.** Ten- to 12-week-old female A/J mice were grouped by ten in an 11.5 in. long  $\times$  7.5 in. wide  $\times$  5 in. deep polycarbonate breeding cage for one week in order to synchronize ovulation. Females were then randomly mated one to one with A/J males of a similar age and checked for vaginal plugs on the mornings of the next four days. Males were removed from females at the appearance of plugs. Date of plugging, as well as weight of sire and dam were recorded. Females that were not plugged were grouped for a week before breeding again.

Plugging was considered to be day one of preg-

nancy and females were placed in fresh breeding cages with wood chips for the duration of their pregnancy and lactation. At plugging, females were randomly assigned to either a control group which was given distilled water or a treatment group which was given 100 ppm sodium chlorite (Matheson, Coleman and Bell, Norwood, OH 45212) in distilled water. A dose of 100 ppm  $\text{ClO}_2^-$  was selected, since other studies (12,13,23) have shown that effects on hematological parameters are first observed at concentrations of chlorite reaching 50 to 100 ppm. Females remained on the specified water during gestation and lactation periods, and water intake was monitored during this time.

At parturition each litter was examined and data collected. Individual birth weights were taken and pups were weighed once a week until weaning at 28 days. Statistical analysis was performed on the data collected for each litter as well as water consumption and rate of positive pregnancy for each group.

**Effects of Renal Structure.** Water used for all treatment and control groups was processed by a Continental Water Deionization System (Millipore Corp., Bedford, Mass) and buffered with 1/30  $M$  Sorenson's phosphate buffer (24) to maintain a pH of 7.17. Treatment water was prepared by the addition of appropriate amounts of  $\text{NaClO}_2$  (Matheson Coleman and Bell, Norwood, Ohio) to buffered "Continental" water. Water used for control groups was prepared in a similar fashion with the addition of  $\text{NaCl}$  (Sigma Chemical Co., St. Louis, MO) instead of  $\text{NaClO}_2$ . All water for treatment and control mice was available *ad libitum*, and the amount of water consumed was recorded at every fresh change. Measurement of chlorite ion concentration in freshly prepared treatment water was performed using the DPD ferrous titrimetric method of Palin (25).

All mice were weighed and randomly allocated to specific time-exposure and treatment groups. Lengths of exposures of treatment and control mice were divided into three time-exposure periods: one group of 55 mice for 30 exposure days, one group of 55 mice for 90 exposure days, and one group of 60 mice for 180 exposure days. The five treatment groups within each time-exposure group were: 0.0 ppm  $\text{NaClO}_2$  as a negative control, 4.0 ppm  $\text{NaClO}_2$  (2.98 ppm as  $\text{ClO}_2^-$ ), 20.0 ppm  $\text{NaClO}_2$  (14.92 ppm as  $\text{ClO}_2^-$ ), 100.0 ppm  $\text{NaClO}_2$  (74.59 ppm as  $\text{ClO}_2^-$ ), and 100.0 ppm sodium chloride ( $\text{NaCl}$ ) as a high salt control.

Upon completion of their respective treatment periods, all animals were weighed and killed by cervical dislocation. Both kidneys were excised, weighed, divided longitudinally into two hemisections, and placed in appropriate fixatives for subsequent light microscopy and/or transmission electron micros-

copy. In preparation for light microscopy, portions of renal tissue were fixed for 12 hr in Helly's solution and subsequently chromated for 12 hr in a 3% potassium dichromate solution (24). Kidney hemisections were embedded in paraffin, cut in 5  $\mu$ m sections, and stained with hematoxylin and eosin-phloxine B. Renal tissue from three randomized mice in each group were processed for electron microscopy. Portions of renal tissue were cut in 1.5 cm blocks and fixed overnight at 4°C in 2.6% glutaraldehyde in Millonig's phosphate buffer at pH 7.2 (26). The renal tissue was then finely diced and post-fixed for 1 hr in Millonig-buffered 1% osmium tetroxide solution. After Epon embedding and ultrathin sectioning, the tissues were stained with 7% uranyl acetate and lead citrate (27). Electron microscopy was performed by use of a Joel 100-S electron microscope at 80 kV.

## Results

### Effect of Chlorine Dioxide and Chlorite on Blood Characteristics

A total of 11 hematologic parameters were measured for effects of chlorine dioxide exposure. Mice exposed to sodium chlorite for 30 days exhibited treatment effects for three of the eleven hematologic parameters (Table 1). Specifically, there was an increase in G6PD activity, MCV (mean corpuscular volume) and osmotic fragility for both strains of mice exposed to the 100.0 ppm chlorite, whereas no significant differences from controls occurred for the 1.0 and 10.0 ppm chlorite exposures.

It is also evident from analysis of variance (Table 1) that there is a significant difference between

strains for both G6PD activity ( $p < 0.001$ ) and osmotic fragility ( $p < 0.001$ ). There were no significant strain versus treatment interactions, indicating that both strains acted similarly to chlorite exposure with respect to the parameters measured. These differences in hematological parameters from treatment could not be explained by weight loss or gain ( $p = 0.146$ ), or by differences in water consumption ( $p = 0.291$ ) since there were no significant treatment effects with respect to these parameters.

### Effect of Chlorite on Conception Rate and Litters of A/J Strain Mice

The means, standard deviations and *t*-results are presented for control and treatment groups in Table 2. The average number of pups born alive in each litter was 5.4 for controls and 5.0 for the treatment group ( $p = 0.33$ ). The average number of pups alive at weaning (4 weeks after birth) was greater at 4.2 pups for controls than for the 3.4 pups in the treatment group ( $p = 0.24$ ). In contrast to the number of living pups, the average number of pups per litter dead at birth was 1.5 for controls and 2.0 for treatment animals ( $p = 0.25$ ). The average number of pups per litter that died after birth but before weaning was 1.3 for controls and 1.9 for the treatment group ( $p = 0.214$ ).

The control litters had an average live birth litter weight of 1.27 g compared with 1.17 g for the treatment group ( $p = 0.13$ ). Two variables where statistical significance was reached includes the averaged weight of pups at weaning and the average birth to weaning growth rate. The birth to weaning growth rate was 0.336 g/day for treatment animals while being significantly greater at 0.408 g/day for

Table 1. Analysis of variance and cell means for selected hematologic variables of A/J and C57L/J mice exposed to 0.0, 10.0, and 100.0 ppm of sodium chlorite.

Parameter	Treatment, ppm NaCl	Cell means for			Analysis of variance results <sup>a</sup>			
		A/J strain	Na	C57L/J strain	N	S	T	ST
G6PD activity, IU/g of hemoglobin in whole blood	0.0	6.10	16	1.88	14			
	1.0	6.05	12	1.74	11	0.000	0.000	0.902
	10.0	5.90	12	1.82	11			
	100.0	6.50	23	2.13	23			
Mean corpuscular volume	0.0	48.91	16	49.89	14			
	1.0	48.70	12	49.47	11	0.100	0.008	0.844
	10.0	48.58	12	49.25	11			
	100.0	50.39	23	50.55	23			
Osmotic fragility	0.0	0.440	12	0.458	11			
	1.0	0.440	12	0.453	11	0.000	0.084	0.875
	10.0	0.438	12	0.458	11			
	100.0	0.452	12	0.465	11			

<sup>a</sup>N = number of mice tested per cell. Probability *F* exceeded for strain differences (S); treatment (T) differences; and strain versus treatment (ST) interactions. When retested by orthogonal contrasting, significance was achieved ( $p = 0.05$ ) for individual treatments.

**Table 2. Differences between control (0.00 ppm chlorite) and treatment (100 ppm chlorite) groups for ten variables.<sup>a</sup>**

Variable	Control group			Treatment group			<i>t</i> -test <sup>b</sup>		
	Mean	S	N	Mean	S	N	<i>t</i>	df	<i>p</i>
Liver litter size	5.4	2.5	21	5.0	3.3	12	0.42	31	0.339
No. alive at weaning	4.2	2.4	19	3.4	3.7	12	0.73	29	0.237
Avg. pup weaning weight	12.5	1.6	16	10.7	2.4	7	2.06	21	0.026
Birth-weaning growth rate	0.408	0.055	16	0.336	0.082	7	2.11	21	0.024
Gestation time	20.2	0.68	9	19.71	1.30	12	1.16 <sup>b</sup>	17.1 <sup>b</sup>	0.110
Breeding weight of mother	21.84	2.16	13	21.03	1.57	12	1.07	23	0.149
Age of mother at parturition (weeks)	18.0	3.9	21	18.5	4.21	12	—	—	—
Average liver birth litter weight	1.27	0.380	20	1.17	0.113	10	1.15 <sup>b</sup>	24.7 <sup>b</sup>	0.130
No. dead at birth	1.50	2.01	20	2.00	2.04	12	-0.68	30	0.252
No. survivors dying before weaning	1.32	1.77	19	1.90	2.02	10	-0.81	27	0.214

<sup>a</sup>S = standard deviation; N = number of litters.

<sup>b</sup>*t*-separate statistic, with adjusted degrees of freedom, are presented, since the variances of the control and treatment groups are shown to be unequal by the *F*-test ( $p = 0.10$ ). Results are based on a one-sided test ( $H_A$ : mean for controls litters > mean for treatment litters).

**Table 3. Analysis of variance for body weight (BW) change, kidney weight (KW), kidney: body weight ratio and weekly water consumption.**

Parameter measured	No. of mice	Analysis of variance <sup>a</sup>		
		<i>L</i>	<i>T</i>	<i>L</i> × <i>T</i>
Body weight change	167	0.000	0.690	0.808
Kidney weight	167	0.000	0.602	0.331
KW:BW ratio	167	0.103	0.348	0.602
H <sub>2</sub> O consumption	166	0.023	0.948	0.519

<sup>a</sup>Probability *F* exceeded for length of exposure differences (*L*), treatment differences (*T*), and length of exposure versus treatment interactions (*L* × *T*).

the control group ( $p = 0.024$ ). Further, the average weight at weaning was 10.7 g for the treatment group and 12.5 g for the control group ( $p = 0.026$ ).

The conception rate was also determined for control and treatment groups. All females positive for vaginal plugs were randomly placed into control and treatment groups. Not all plugged females conceived or produced litters. The percentage of dams that were plugged that also produced litters was defined as the conception rate. The conception rate for the treatment group was 39% and for controls was 56%.

Since differences between groups in the weight of dams, age, gestation time, or the amount of water consumed might have influenced the development of pups, these variables were measured. The gestation time of dams was not statistically different between control and treatment groups ( $p = 0.110$ ). The average breeding weight of the treatment and control dams was 21.03 and 21.84 g, respectively ( $p = 0.149$ ), while the age of mothers at parturition was 18 weeks for controls and 18.5 weeks for the treatment group. Finally, the level of water intake between control and treatment groups was measured. The water consumed during lactation is usually greater than that consumed during gestation, so

these figures are presented separately. The control dams consumed an average of 5.9 ml/day during gestation and 15.6 ml/day during lactation. The treatment group consumed 6.2 ml/day of chlorite-treated water during gestation and 15.3 ml/day during lactation. The difference between treatment and control groups in the amount of water consumed was not significant for gestation period ( $p = 0.08$ ) or lactation period ( $p = 0.87$ ).

### Effect of Chlorite Exposure on Kidney Structure

Two-way analysis of variance revealed no statistically significant treatment-related differences for any of the four physical parameters measured (body weight change, kidney weight, percent kidney to body weight ratio and weekly water consumption). Statistically significant length of exposure differences were observed in body weight change, kidney weight, and weekly water consumption; but a significant difference was absent in the percent kidney to body weight ratio (Table 3). Additionally, no significant interaction occurred between length of treatment exposures and treatment levels of any of the four parameters.

Chi-square analysis of mortality rates indicated that these rates were not significantly different between the 30-, 90- and 180-day groups nor between the five various treatment levels.

Macroscopically, the kidneys were normal. The kidneys' outer surfaces were smooth, encapsulated, and pinkish-brown in color. No external lesions or growths were observed. Internally, the kidneys were unilobar with a dark red medulla and a pinkish-red cortex. No internal lesions, growths or obstructions were observed.

Microscopic examination using light and transmission electron microscopes revealed no evidence of glomerular, vascular, obstructive or tubular disease. Glomeruli, vasculature, and tubular networks were free from significant nephritis, nephrosis, vascular sclerosis, and obstructions. Ultrastructural or minimal changes were not found.

## Discussion

Based upon the data in this study and a previous one (23), it appears that exposure of A/J and C57L/J mice to 100 ppm of chlorite for 30 days produces increases in G6PD activity, mean corpuscular volume, osmotic fragility and acanthocytosis (regular deformations or projections on the cell surface). *In vitro* studies by Heffernan (11,12) revealed that incubation of human and rat erythrocytes with increasing concentrations of  $\text{ClO}_2^-$  produced a progression of alterations in the erythrocyte morphology. Concentrations of  $7.4 \times 10^{-4} M$  to  $7.4 \times 10^{-3} M$   $\text{ClO}_2^-$  produced multiple sharp pointed deformations on the membrane similar to effects seen in our *in vivo* studies. *In vivo* studies by Abdel-Rahman et al. (28) showed morphologic changes in the erythrocytes of rats and chickens drinking  $\text{CO}_2$ ,  $\text{ClO}_2^-$ , and  $\text{ClO}_3^-$  daily for 3 months. These changes were in the form of crenated spheres (echinocytes) with distortions in the middle of the erythrocytes at 100 mg/l. of  $\text{ClO}_2^-$ . The morphologic changes to erythrocytes produced by *in vivo* or *in vitro*  $\text{ClO}_2^-$  exposure appear consistent among the results of different experimenters with the *in vivo* threshold at 100 mg/l. of  $\text{ClO}_2^-$ .

The studies of both Heffernan et al. (13) and Abdel-Rahman et al. (28) demonstrated a decrease in GSH levels of erythrocytes after *in vivo* exposure of rats to chlorite. Neither the A/J or C57L mice in our study revealed a similar decrease in GSH. However, G6PD activities were elevated, indicating that in the mice adaptation may have been sufficient to prevent measurable decreases in GSH. This did not preclude damage to cell membranes which may be protected by other mechanisms.

Heffernan et al. (13) reported that when rats

were fed sodium chlorite, the levels of GSH were the most markedly affected of the blood parameters and declined in dose-response relation to chlorite exposure, with levels of chlorite at 60 ppm causing decreases of approximately 20% in GSH levels. Additionally, decreases in hemoglobin, red cell count and packed cell volume were also evident in the study of Heffernan et al. (13), indicating a mild hemolytic anemia. The present studies on mice (23) exposed to 100 ppm chlorite indicated an increase in MCV (mean corpuscular volume), osmotic fragility, G6PD activity and the number of acanthocytes. Recent *in vitro* studies by Moore et al. (29) have revealed that human G6PD-deficient red cells are more susceptible to chlorite-induced decreases in GSH than are cells of humans with normal G6PD activity. Future studies are needed to quantify to what extent G6PD deficient cells may be at risk to chlorite induced RBC alteration in normal exposure conditions.

It should be emphasized that while the activity of A/J strain was three times that G6PD activity of the C57L/J strain, a value comparable to the ratio of normal to deficient human RBC G6PD activity, the absolute comparisons are quite dissimilar. That is, the C57L/J mice (i.e., the so-called "deficient" strain) have RBC G6PD activity similar to that of normal humans even though they showed only 1/3 the activity level of the A/J strain. Thus, the C57L/J strain did not represent a true deficient in absolute terms. In fact, their ability to increase GSH levels following chlorite stress suggests the ability to adapt to oxidant stress. Likewise, unpublished investigations in our laboratory have shown that the C57L/J mice were markedly resistant to primaquine, an oxidant drug which is known to induce hemolytic anemia in G6PD deficient humans (15). It thus seems that the hypothesis that G6PD deficiency enhances the occurrence of chlorite-induced hemolysis in humans remains to be evaluated via a model with a deficiency comparable in absolute terms to the human deficient condition and/or epidemiologically.

Our studies of chlorite exposure on conception rate and litters of A/J mice have demonstrated that there are no effects of ingested chlorite ion (100 ppm) on pregnant dams when measuring gestation time, breeding weight or age at parturition. Consequently, these variables do not appear to confound the results. Additionally, there is no significant difference in litter size, which also rules this out as a confounding factor in influencing weaning weight and birth-weaning growth rate. Although the number of pups alive at weaning was somewhat greater for the controls, this difference again was not significant. It would be expected that fewer mice in a litter either at birth or prior to the weaning process would result in greater weight gains. How-

ever, there were fewer in the treatment groups alive at weaning, yet they weighed significantly less on the average than controls, and had less weight gain. These results appear similar to those of Shuval and Gruener (19) who reported that pups of dams while drinking water with nitrite (1000–3000 mg/l.) experienced increased mortality in the first three weeks and lagged behind in growth, despite having equal birth weights to controls. The conception rate of the dams drinking chlorite-treated water was reduced 17% compared to controls. These findings indicate that chlorite ion at 100 ppm concentration is capable of reducing the conception rate of A/J mice and of retarding the growth rate of A/J pups through weaning. Levels of 100 ppm chlorite represent a 10- to 100-fold increase over expected concentrations in drinking water and additional studies are being undertaken to determine minimal health effect levels. **The series of sodium chlorite doses administered orally in drinking water did not result in any detectable toxic damage to the kidneys of C57L/J male mice over the 60-, 90- or 180-day exposure periods.**

Environmental Protection Agency Health Effects Research Group in Cincinnati, OH, grant number R-805-993-020. Segments of this research have appeared previously (29,30).

## REFERENCES

- U. S. Environmental Protection Agency. Preliminary assessment of suspected carcinogens in drinking water. Report of Congress compiled by Office of Toxic Substances Environmental Protection Agency, Washington, D.C., 1975.
- Rook, J. J. Halforms in drinking water. *J. Am. Water Works Assoc.* 68: 168–172.
- National Cancer Institute. Report on the carcinogenesis bioassay of chloroform, NCI. Bethesda, Md, 1976.
- Maryx, J. L. Drinking water: Another source of carcinogens? *Science* 186: 809–811 (1974).
- Droven, T. A., and Diem, J. E. The New Orleans drinking water controversy. *Am. J. Publ. Health* 65: 1060 (1975).
- Stevens, H., Seeger, D., and Slocum, C. J. Products of chlorine dioxide treatment or organic materials in water. Paper presented at workshop on ozone/chlorine dioxide oxidation products of organic materials, Nov. 17–19, 1976, Cincinnati, Ohio, Water Supply Research Division, EPA, 1976.
- U. S. Environmental Protection Agency. Manual of treatment techniques for Meeting the Interim Primary Drinking Water Regulations. Water Supply Research Division, EPA, Cincinnati, Ohio, 1977.
- Miltner, R. J. Measurement of chlorine dioxide and related products. proceeding AWWA Quality Technology Conference, Dec. 6–7, 1976, San Diego, AWWA, Denver, 1977, Paper No. 2A-S.
- Richardson, A. P. Toxic potentialities of continued administration of chlorate for blood and tissues. *J. Pharmacol. Exptl. Therap.* 59: 101 (1937).
- Jung, F. Zur Theorie der Chloratvergiftung. III. Naunyn-Schmiedelbergs Arch. Exptl. Pathol. Pharmacol. 204: 157–165 (1947).
- Heubner, W., and Jung, F. Zur Theorie der Chloratvergiftung. *Schweiz. Med. Wochenschr.* 71: 247–250 (1941).
- Heffernan, W. P., Guion, G., and Bull, R. J. Oxidative damage to the erythrocyte induced by sodium chlorite, *in vitro*. *J. Environ. Pathol. Toxicol.* 2: 1501–1510 (1979).
- Heffernan, W. P., Guion, G., and Bull, R. J. Oxidative damage to the erythrocyte induced by sodium chlorite, *in vivo*. *Environ. Pathol. Toxicol.* 2: 1487–1500 (1979).
- Wintrobe, W. M., Lee, R. G., Boggs, D. R., Bithell, T. C., Othens, J. W., and Foerster, N. The erythrocyte: morphology, intrinsic metabolism, function, laboratory evaluation. In: *Clinical hematology*, 7th ed. Lea and Febiger, Philadelphia, 1975, pp. 103–105.
- Beutler, E. Glucose-6-phosphate dehydrogenase deficiency. In: *Metabolic Basis of Inherited Diseases*, J. B. Stanbury, J. B. Wyngaarden and D. S. Fredrickson (Eds.), McGraw-Hill, New York, 1972.
- Hansen, H. E. and Bennett, J. J. In: *Textbook of Pediatrics*. W. E. Nelson, Ed., W. B. Saunders Co., Philadelphia, 1964, p. 109.
- Lehmann, H., Huntsman, R. G., and Ager, J. A. The hemoglobinopathies and Thalassemia. In: *The Metabolic Basis of Inherited Disease*, J. B. Stanbury, J. B. Wyngaarden, D. S. Fredrickson (Eds.), McGraw-Hill, New York, 1972, p. 100.
- Emerson, P. M. Erythrocyte glutathione peroxidase content and serum tocopherol levels in newborn infants. *Brit. J. Haematol.* 22: 667–671 (1972).
- Shuval, H. T., and Gruener, N. Health effects of nitrates in water. Health Effects Research Laboratory, Cincinnati, Ohio 45268, 1977, Environmental Health Effects Research Series, EPA 600/1-77-030.
- Koransky, W. Beitrag zur Theorie der Chlorat Oxydation. *Naunyn-Schmiedelbergs Arch. Exptl. Pathol. Pharmacol.* 215: 483–491 (1952).
- Seiverd, C. F. *Hematology for Medical Technologists*. Lea and Febiger, Philadelphia, 1972, p. 110.
- Dixon, W. J., and Massey, F. J., Jr. *Introduction to Statistical Analysis*. McGraw-Hill, New York, 1969, pp. 151–155, 175–181.
- Moore, G. S., and Calabrese, E. J. The effects of chlorine dioxide and sodium chlorite on erythrocytes of A/J and C57L/J mice. *J. Environ. Pathol. Toxicol.* 4 (2, 3): 513–524 (1980).
- Humason, G. L. *Animal Tissue Techniques*. W. H. Freeman and Co., San Francisco, 1972, p. 5543.
- Paulin, A. J. Analytical control of water disinfection with special reference to differential DPD methods for chlorine, chlorine dioxide, bromine, iodine, and ozone. *J. Inst. Water Engr.* 28: 139–154 (1974).
- Millonig, G. Advantages of a phosphate buffer for OsO<sub>4</sub> solutions in fixation. *J. Appl. Phys.* 32: 1637–1642 (1961).
- Reynolds, E. S. The use of lead citrate at high pH as an electron opaque stain in electron microscope. *J. Cell Biol.* 17: 208 (1963).
- Abdel-Rahman, M. S., Couri, D., and Bull, R. J. Kinetics of ClO<sub>2</sub> and effects of CO<sub>2</sub>, ClO<sub>2</sub><sup>-</sup>, and ClO<sub>3</sub><sup>-</sup> in drinking water on blood glutathione and hemolysis in rat and chicken. *J. Environ. Pathol. Toxicol.* 3: 431–449 (1980).
- Moore, G. S., Calabrese, E. J., and Ho, S. C. Groups at potentially high risk from chlorine dioxide treated water. *J. Environ. Pathol. Toxicol.* 4 (2, 3): 465–470 (1980).
- Moore, G. S., Calabrese, E. J., and Leonard, D. A. Effects of chlorate exposure on conception rate and litters of A/J strain mice. *Bull. Environ. Contam. Toxicol.* 25: 689–696 (1980).

# Chlorine Dioxide and Teat Conditioning—It Works!

It's been clear for years: the chlorine dioxide class of teat dips effectively prevent mastitis. Numerous studies following NMC protocols prove it.<sup>1</sup> Satisfied customers around the globe applaud it. And somewhere along the way, while these dips were working hard to protect cows from mastitis, a welcome upshot became apparent: bad teat ends improved with chlorine dioxide usage.

Though no formal study unveiled this discovery, positive field reports have poured in and continue to do so. Its effect on bad teats has been so predictable, even foremost milk quality consultants have taken note, recommending chlorine dioxide teat dips to help heal teats with hyperkeratosis, or rough teat ends.<sup>2,3</sup> Their observations indicate the chlorine dioxide class of teat dips are very effective in softening keratin, allowing keratin removal with aggressive action during udder prep.

## Softening is Key

The question has been posed that if chlorine dioxide (ClO<sub>2</sub>) “dissolves hyperkeratotic tissue, wouldn't it also dissolve skin?”

Chlorine dioxide does not “dissolve” hyperkeratotic tissue. It softens it for easier removal. Lactic acid, the activator in the system, (the same activator as in all ABS udder care products) is an alpha-hydroxy acid (AHA). The functional benefits provided by AHAs are skin softening and exfoliating.<sup>4</sup>

## What about the pH?

There are claims that low pH is bad while products with moderate pH (pH about 5 or 6) are more desirable for skin. These generalizations about pH are not accurate. It is recognized that a strong acid can be corrosive to skin; however, not all acidic products are bad for skin. Chlorine dioxide products, with pH levels ranging from 2.7 to 3.2, are proof. Lab testing of these products



Teat exfoliation as a result of ABS udder care products



End result of exfoliation, healthy teat condition

shows improved skin hydration. Field experience echoes the lab results. Furthermore, one can design a pH 5 iodine teat dip that can be very harsh to skin. Therefore, it is difficult to make broad cause-and-effect generalizations on pH.

“We have measured the skin surface pH of cows' teats and they are essentially neutral,” says Dr. Joseph Morelli, Ecolab Senior Scientist. “This has been examined by researchers in Germany. Prolonged application of a ClO<sub>2</sub> teat dip vs. a nil treatment control had no significant impact on the skin pH.<sup>5</sup> What does this tell us? There is no basis, physiological or otherwise, to say one pH is better than another. In addition, use of a low pH formula does not significantly alter the skin's inherent pH.”

## Summary

As you consider your teat dip selection, remember:

1. Chlorine dioxide softens hyperkeratotic tissue for easier removal.
2. Chlorine dioxide pH level does not alter the skin's inherent pH.

To learn more about ClO<sub>2</sub> please see the question and answer section below. 

<sup>1</sup> Summary of Peer-Reviewed Publications  
[www.nmconline.org/docs/Teatbibl.pdf](http://www.nmconline.org/docs/Teatbibl.pdf)

<sup>2</sup> Johnson, A. 2003. Hoard's Dairyman, May 10, p. 341.

<sup>3</sup> Reid, D.A. and A. P. Johnson. 2003. 42nd Annual National Mastitis Council Meeting Proceedings, pp. 124-127.

<sup>4</sup> FDA Draft Guidance.  
[www.cfsan.fda.gov/~dms/ahaguide.html](http://www.cfsan.fda.gov/~dms/ahaguide.html)

<sup>5</sup> Fox, L.K., L.Y. Oura, and C.R. Ames. 2003 J Dairy Sci. 86 (12):3951-2.

## What is Chlorine Dioxide?

Chlorine dioxide (ClO<sub>2</sub>), the primary germicide in ABS udder care products, is an incredibly effective broad-spectrum, anti-inflammatory, bactericidal, fungicidal and virucidal agent. Chlorine dioxide has been recognized for its disinfectant properties since the early 1900's. In 1967, the EPA first registered the liquid form of ClO<sub>2</sub> for use as a disinfectant and sanitizer.

## Where else has ClO<sub>2</sub> been used for disinfection?

Although ClO<sub>2</sub> has been used in udder disinfection for the past 20 years, it is no stranger to many other industries and has been used commercially for over 60 years. It is used for disinfection and odor control and is known for its broad-spectrum killing ability.

Some examples of industrial ClO<sub>2</sub> use include:

- washing fruit and vegetables
- disinfecting meat and poultry
- disinfecting food processing equipment
- controlling odors
- medical disinfection
- treating municipal water
- bleaching pulp and paper
- electronics - circuit board cleaning

In addition, in November 2001, the EPA began to use liquid ClO<sub>2</sub> in the cleanup of government buildings against Anthrax.

### **Is ClO<sub>2</sub> the same as bleach?**

No. While ClO<sub>2</sub> has chlorine in its name, chlorine dioxide's chemistry is radically different than that of chlorine. Bleach is a hypochlorite/hypochlorous acid, which is a more corrosive oxidizing system. Chlorine dioxide is gentler on hands and teat skin and has less tendency to become inactivated by organic matter (mud, manure, milk) than bleach.

### **Is ClO<sub>2</sub> non-toxic? What about residues?**

Chlorine dioxide is residue safe. The active ingredients break down to products naturally found in the environment - organic acids and sodium chloride (table salt). It is environmentally friendly and not harsh on teat skin. In fact, all of the ABS formulations are fast, safe and effective.

### **What are the advantages of a ClO<sub>2</sub> udder care product versus an iodine?**

Chlorine dioxide products are more effective under organic load. When milk, mud or manure are present on teats, these organic materials increase the pH on the

skin. Iodine is negatively affected by these pH increases and loses killing ability with the organic material present. Chlorine dioxide is not affected by this high pH level when organic materials are present and is able to maintain killing ability.

Also, ClO<sub>2</sub> products have proven to have a quick kill – a 15 second kill as proven in standardized tests developed by the Association of Analytical Chemists (AOAC). With these AOAC testing methods, germicides must achieve a 5-log reduction in 15 seconds to be considered effective. The ABS udder care products provide a 5-log kill in 15 seconds – with and without a 10% milk load. 

## Integrated chlorine dioxide technology

### Low cost production of ClO<sub>2</sub> without importing sodium chlorate

The Chemetics integrated chlorine dioxide process offers a low cost method of producing chlorine dioxide without the requirement to import feedstock chemicals.

By making chemicals in-situ, our process offers a reliable supply and avoids a dependence on the market, while eliminating the costs, uncertainty, safety issues and administration in importing and storing large quantities of sodium chlorate, sulphuric acid, methanol, and ion peroxide.

Since the only inputs are chlorine (typically from an on-site chlor-alkali plant), power, and water – our proven process offers the lowest cost method to produce chlorine dioxide, with no salt cake for disposal.

Chlorine dioxide solution with a low chlorine content is produced by our modern ClO<sub>2</sub> generation process, for use in producing ECF-grade bleached pulp.

With over 30 references, our integrated chlorine dioxide technology has been adopted by world class pulp mills as a means to gain a production cost advantage to balance chlorine/caustic consumption, and/or to avoid the dependence on external chemical suppliers.

Our well-established and efficient process consists of three plant areas to produce sodium chlorate, hydrochloric acid, and chlorine dioxide, which are integrated into a single, efficient plant design with low maintenance requirements.

The Chemetics Integrated Chlorine Dioxide System has been continuously improved since the first installation in 1978, resulting in a design that is safe, reliable, efficient, and easy to operate.

Chlorine dioxide generator  
▶

Electrolyzer  
▶ ▶

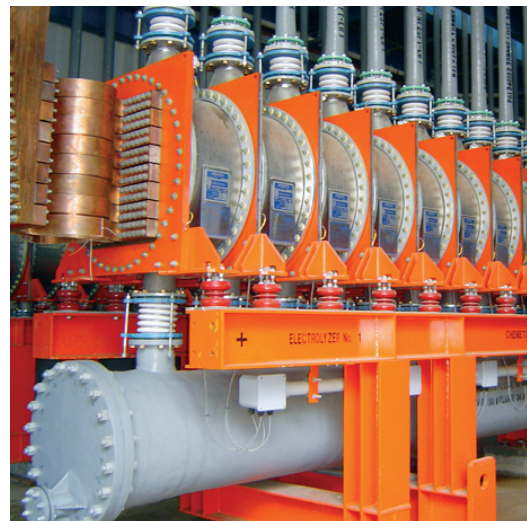
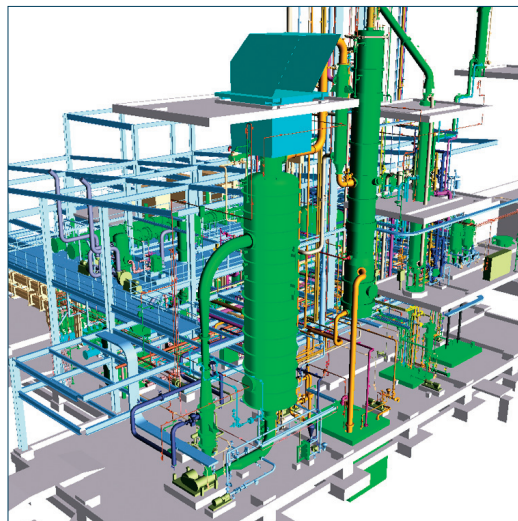



### Overall process integration

As illustrated, the Chemetics Integrated Chlorine Dioxide System consists of three plant areas to produce the two intermediate products, sodium chlorate ( $\text{NaClO}_3$ ) and hydrochloric acid (HCl), and the final product, chlorine dioxide ( $\text{ClO}_2$ ).

Sodium chlorate is produced by passing an electric current through a solution that contains sodium chloride (salt) to make strong sodium chlorate liquor. The salt for this reaction is a recycled by-product from the chlorine dioxide production area. Hydrogen gas is co-produced with the sodium chlorate, and is used as a feedstock for hydrochloric acid production.

Hydrochloric acid is produced by burning chlorine gas and hydrogen gas. The hydrogen gas comes from the sodium chlorate electrolysis

area. Make-up chlorine gas comes from the plant battery limits. Weak chlorine gas, a recycled by-product of the chlorine dioxide generation area, is combined with this chlorine make-up stream prior to being burned with the hydrogen gas.

Chlorine dioxide gas is produced, along with chlorine gas and sodium chloride (salt), by combining strong chlorate liquor and hydrochloric acid in the chlorine dioxide generator. The chlorine dioxide gas is absorbed in chilled water and then stripped with air to remove residual chlorine, to produce a high-purity chlorine dioxide solution for use in the ECF pulp mill bleach plant.

The liquor leaving the generator contains unreacted sodium chlorate and the by-product salt. This solution, called weak chlorate liquor, is recycled back to the sodium chlorate electrolysis area for reconcentration. The chlorine by-product (weak chlorine), which is not absorbed, is recycled for hydrochloric acid production.

As a result of the integration of these three plant areas, the key operating costs are for make-up chlorine, and for electrical energy that is consumed in sodium chlorate electrolysis area. With these relatively low-cost inputs, the integrated chlorine dioxide process offers much lower production costs than competing processes that require the purchase of sodium chlorate, acids, methanol, and/or hydrogen peroxide.

Chemetics' proven, low-operating cost process for the production of chlorine dioxide without sodium chlorate import. Inputs to the process are just water, chlorine, and electricity.

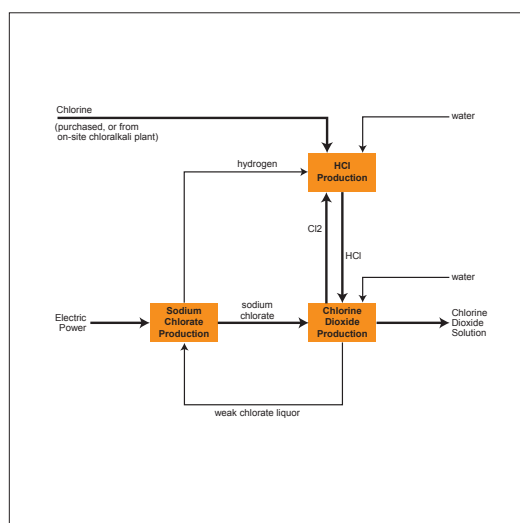

### Performance Data

#### $\text{ClO}_2$ Solution Specification

$\text{ClO}_2$ :	8 – 10 g/L
$\text{Cl}_2$ :	0.2 g/L
HCl:	0.5 – 1.0 g/L

#### Consumption per tonne of $\text{ClO}_2$

Raw Materials:	Chlorine 0.7 tonne
Power:	Power 8,500 – 9,500 kWh D.C.

### Features:

- Lowest production cost
- High purity (low chlorine product)
- No purchased chlorate, acid, methanol, or peroxide is required
- Security of supply for feedstocks
- Improves the balance of pulp mill chlorine/caustic consumption
- No solids handling
- No salt cake for disposal

# Investigation on virucidal activity of chlorine dioxide. Experimental data on Feline calicivirus, HAV and Coxsackie B5

R. ZONI, R. ZANELLI, E. RIBOLDI, L. BIGLIARDI, G. SANSEBASTIANO  
Department of Public Health, Sec. Hygiene, University of Parma, Italy

## Key words

Chlorine dioxide • Virucidal activity • Disinfection treatment

## Summary

**Introduction.** The aim of this study was to evaluate the efficacy of  $\text{ClO}_2$  with regard to viruses which show a particular resistance to oxidizing agent such as HAV and Norwalk and Norwalk-like viruses, and which play an important role in the epidemiology of viral foodborne diseases.

In the food industry, disinfection of processing systems and equipment is a very important instrument to prevent secondary contamination and to guarantee food safety. Among disinfectants, chlorine dioxide ( $\text{ClO}_2$ ) presents a good efficacy at wide range of pH values, its action is rapid and generates few reaction by-products if compared to hypochlorite. Experimental studies have highlighted that  $\text{ClO}_2$  shows a good bactericidal activity and it is also active towards viruses. Furthermore, the low concentrations and low contact times required to obtain microbial load reduction are favourable elements for the application of this compound in the industrial sanitizing practices.

**Methods.** As it is impossible to cultivate the Norwalk virus *in vitro*, we tested the resistance of Feline calicivirus (F9 strain) vs.  $\text{ClO}_2$ , in comparison with HAV (strain HM-175) and Coxsackie B5. Chlorine dioxide was used at concentrations ranging from 0.2 to 0.8 mg/l in water solution, at pH 7 and at +20 °C. Viral suspensions were added

to disinfecting solution and, at pre-set times, were sampled to undergo to titration after blocking the disinfectant action with thiosulphate 0.05 M. On the basis of the data obtained, for each virus and in relation to different concentrations, mean reduction times were calculated for 99%, 99.9% and 99.99% using the regression analysis model.

**Results.** As regards Feline calicivirus, at a concentration of 0.8 mg/l of  $\text{ClO}_2$ , we obtained the complete elimination of the viral titre in 2 min while 30 min were required at concentrations of 0.2 mg/l. Coxsackie B5 showed a similar behaviour, being completely inactivated in 4 min with 0.4 mg/l of  $\text{ClO}_2$  and after 30 min at a concentration of 0.2 mg/l. Inactivation was quicker for HAV, which was eliminated after only 30 sec at a concentration of 0.8 mg/l and after 5 min at 0.4 mg/l.

**Conclusion.** Our data show that for complete inactivation of HAV and Feline calicivirus, concentrations  $\geq 0.6$  mg/l are required. This observation is true for Coxsackie B5 too, but this virus has shown a good sensitivity at all concentration tested according to regression analysis results. For Feline calicivirus and HAV, at low concentrations of disinfectant, prolonged contact times were needed to obtain a 99.99% reduction of viral titres (about 16 and 20 minutes respectively).

## Introduction

Although viruses, unlike bacteria, are incapable for replicating in food, they represent an important cause of foodborne infections.

Viruses with oral-faecal transmission play an important role in the etiological factors involved, and most cases of gastroenteritis are attributed to the Norwalk virus or to the Norwalk-like virus, viruses belonging to the family of caliciviruses, and to the hepatitis A virus.

Food is exposed to risks of primary contamination when the raw materials themselves are contaminated, or secondary contamination when they come into contact with surfaces/equipment which are contaminated [1].

Thus, sanitizing the processing systems and the equipment which comes into contact with the foodstuffs is extremely important in the food industry in order to reduce the risk of secondary contamination, and represents a fundamental instrument to reduce the risk of infection linked to the consumption of foodstuffs.

Hypochlorite and chlorine dioxide ( $\text{ClO}_2$ ) are highly oxidizing and are thus commonly used as disinfectants, especially when disinfecting water.

Studies carried out on potential genotoxic effects of chlorination have shown that the use of sodium hypochlorite leads to the formation of a larger number of mutagen substances than the use of chlorine dioxide [2].

As compared to other oxidizing disinfectants, chlorine dioxide offers certain advantages, such as its efficacy in a wide range of pH values and its rapid action.

If compared to hypochlorite, for instance, it has a higher selectivity and generates a smaller number of reaction products; furthermore, the bactericidal efficacy of  $\text{ClO}_2$  is greater than that of  $\text{HClO}$  since its greater oxidizing capacity has been demonstrated.

Inactivation assays carried out under controlled experimental conditions have shown a different sensitivity towards  $\text{ClO}_2$  on the part of various enteroviruses: at a concentration of 0.32 mg/l in conditions of neutral pH and at a temperature of 15°C, the inactivation time for

Tab. I. Reduction of bacterial load.

Microorganism	Concentration ClO <sub>2</sub> mg/l	Contact Times	% inactivation
<i>Staphylococcus aureus</i>	1.00	60 sec	99.999
<i>Escherichia coli</i>	0.15	300 sec	99.900
<i>Escherichia coli</i>	0.25	60 sec	> 99.999
<i>Streptococcus</i>	1.00	15 sec	> 99.999
<i>Lactobacillus brevis</i>	0.15	5 min	99.900
<i>Lactobacillus brevis</i>	1.00	5 min	> 99.999
<i>Pseudomonas aeruginosa</i>	1.00	60 sec	> 99.999

99.99% was 5 min for *Echo* 7, 3 min for *Coxsackie* B3 and 7 min for the *polio*1 virus [3, 4].

The low concentrations generally required, low contact times and reduced microbial load are favourable elements promoting the use of ClO<sub>2</sub> in the food industry.

Table I illustrates the disinfecting activity of chlorine dioxide [5].

The aim of this study was to assess under experimental conditions the efficacy of chlorine dioxide when used with certain viruses which have proven to be particularly resistant to oxidizing agents, and which has not been thoroughly investigated in the literature.

## Materials and methods

The following were used for the inactivation assays: the feline *Calicivirus* F9 strain grown on CRFK (feline kidney) cultures, the *Coxsackie* B5 virus grown on RC-37 (monkey kidney), and the *Hepatitis A virus* strain HM-175 grown on FRhK4 (monkey kidney embryonic) cultures.

Infected cell cultures were incubated at 37°C until the onset of the cytopathic effect, and subsequently frozen at -80°C to induce cell lysis; the contents of the flask were then submitted to ultra-filtration and re-suspended with sterile physiological solution, and finally aliquoted in sterile test tubes and stored in deepfreeze at -20°C.

The titre of the viral suspension was determined for the hepatitis A virus using the plate method and expressed as PFU, while for the other viruses it was calculated as TCID<sub>50</sub> (titre of the dose infecting 50% of the cell culture) according to the Reed-Muench method; we integrated the titres of 3 or 4 test for each virus and different concentrations.

Chlorine dioxide was used as disinfectant at the following concentrations: 0.2, 0.4, 0.6, 0.8 mg/l.

Viral inactivation assays were carried out at a constant temperature of 20°C with neutral pH kept constant by using a buffer solution at pH 7.

### PERFORMING THE ASSAYS

1 ml of viral suspension was added to the disinfecting solution, then aliquots of samples were collected at pre-set times – T<sub>0</sub>, T<sub>0.5</sub>, T<sub>1</sub>, T<sub>2</sub>, T<sub>3</sub>, T<sub>4</sub>, T<sub>5</sub>, T<sub>15</sub>, T<sub>30</sub>, T<sub>45</sub>, T<sub>60</sub>, – and immediately placed in contact with 0.5 ml

thiosulphate 0.05 M in order to neutralize the disinfectant activity.

For hepatitis A virus, we proceeded by setting up scalar 10-folds dilutions for each contact time and by inoculating them in cell cultures previously grown in 24-wells-plates (0.1 ml/well); the plates were then incubated for 2 hours at 37°C (5% CO<sub>2</sub>). As soon as the contact time has expired, the inoculum was sucked up and a semi-solid medium was added (4% foetal calf serum, 43% MEM 2X, 43% carboxymethylcellulose). After a twelve-days incubation, the cell cultures were fixed with formalin (two hours-contact time), then washed with demineralised water and stained with Giemsa; the following day we washed away the exceeding stain and the cell lysis plaques were counted.

As regards the other viruses assayed, the 10-folds dilutions prepared for each contact time aliquot were placed in 96-wells plates (25 µl/well) previously prepared with 25 µl/well of medium and 50 µl of cell suspension has been added to each well. Finally, after an incubation at 37°C for 4 days, we detected the presence of the cytopathic effect induced by the virus.

## Results

### FELINE CALICIVIRUS

In order to assess the trend of the inactivation assays with *Feline calicivirus*, the logarithms of the titres were calculated and the trends at various concentrations at various times are shown in Figure 1.

At a concentration of 0.8 mg/l the viral titre was eliminated after two minutes, and after thirty minutes at a concentration of 0.2 mg/l.

Mean reduction times were then calculated for 99%, 99.9% and 99.99% inactivation through analysis of regression, giving the results shown in Table II.

Table II shows that at a concentration of 0.8 mg/l a 99.99% reduction was obtained after 2.1 minutes, while 15.5 minutes were required for concentrations of 0.2 mg/l.

### COXSACKIE B5 VIRUS

In this case, logarithms of the titres, as TCID<sub>50</sub>, were calculated too, and results are shown below in Figure 2. It is possible to note that at a concentration of 0.6

**Fig. 1.** Trend of viral titre (log TCID<sub>50</sub>) at different ClO<sub>2</sub> concentration and contact times *Feline calicivirus*.

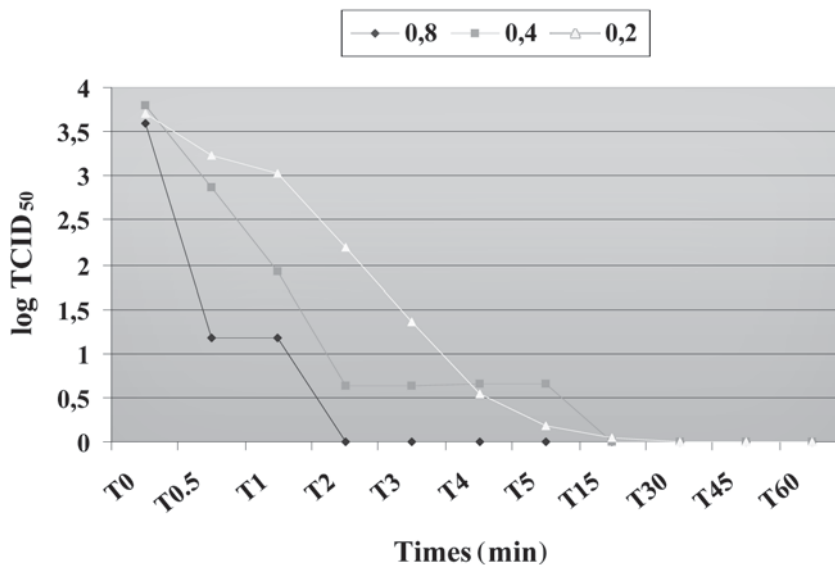

**Tab. II.** Mean reduction times for various inactivation percentages.

<i>ClO<sub>2</sub> – Feline calicivirus – neutral pH</i>			
[ClO <sub>2</sub> ] (mg/l)	Mean time (min) to obtain reduction of:		
	99% (CI 95%)	99.9% (CI 95%)	99.99% (CI 95%)
0.80	0.50 (0.16-0.74)	1.10 (1.05-1.26)	2.10 (2.02-2.22)
0.40	1.24 (0.98-1.52)	3.48 (3.10-3.73)	9.59 (9.16-9.81)
0.20	2.20 (1.80-2.09)	6.20 (5.90-6.90)	15.50 (15.20-15.90)

**Tab. III.** Mean reduction times at various inactivation times.

<i>ClO<sub>2</sub> – Coxsackie Virus B5 – neutral pH</i>			
[ClO <sub>2</sub> ] (mg/l)	Mean time (min) to obtain reduction of:		
	99% (CI 95%)	99.9% (CI 95%)	99.99% (CI 95%)
0.60	0.12 (0.08-0.17)	0.34 (0.27-0.45)	1.00 (0.87-1.15)
0.40	0.57 (0.41-0.79)	1.18 (0.94-1.47)	2.41 (2.20-2.73)
0.20	0.63 (0.45-0.89)	1.52 (1.18-1.95)	3.73 (3.18-4.38)

mg/l the titre was eliminated after 4 minutes, while at a concentration of 0.2 the titre was eliminated after 30 minutes.

By calculating the regression, it was possible to record the mean reduction times at 99%, 99.9% and 99.99%. Results are shown in Table III.

Results show that at concentrations of 0.6 mg/l a 99.99% reduction of the viral titre was obtained after 1 minute, while at a concentration of 0.2 mg/l it was obtained after 3.73 minutes.

**HEPATITIS A VIRUS**

As regards the Hepatitis A virus, the viral titre was calculated according to the PFU method. Figure 3 shows the trends of viral titres at various concentrations

At a concentration of 0.8 mg/l the titre was completely eliminated after only 30 seconds, while at concentrations of 0.4 complete elimination was obtained after 5 minutes.

Finally, mean reduction times for elimination at various percentages were calculated here, too, using the regression analysis as shown in Table IV.

**Considerations and Conclusions**

Chlorine dioxide is an excellent bactericidal agent, as has been reported in various studies, although its virucidal activity has not been thoroughly investigated as yet [6-12].

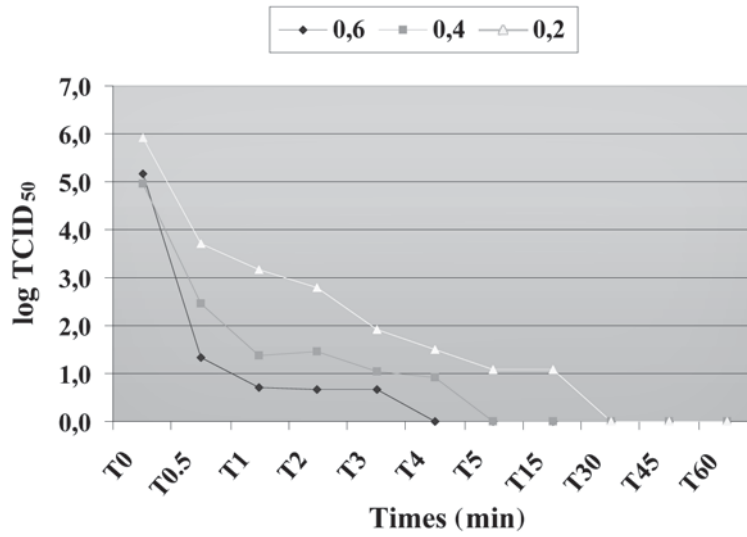
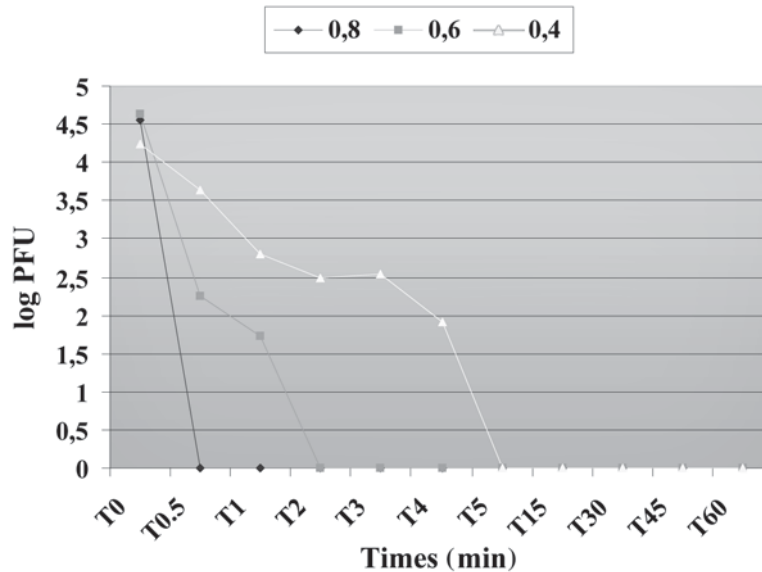
**Fig. 2.** Trend of viral titre (log TCID<sub>50</sub>) at different ClO<sub>2</sub> concentration and contact times Coxsackie B5 virus.**Fig. 3.** Trend of viral titre (log PFU) at different ClO<sub>2</sub> concentration and contact times Hepatitis A virus.

The inactivation kinetics of Poliovirus 1 under experimental conditions have shown that it has a good oxidizing effect [13].

Our results have shown that it is only with concentrations greater than 0.6 mg/l that inactivation is obtained quickly for HAV and for Feline calicivirus, and only Coxsackie B5 shows great sensitivity at all concentrations assayed.

If these data are compared to the inactivation kinetics we performed on Poliovirus 1, the greater resistance

of Calicivirus to Chlorine dioxide is confirmed [14]. This result is particularly important in that it confirms that the Norwalk virus, which the Feline calicivirus is a surrogate of, presents considerable resistance to hypochlorite and is also characterized by strong resistance to Chlorine dioxide. This needs to be taken into account in sanitizing procedures applied to processing systems as well as in direct disinfection treatments of foodstuffs which may be involved as carriers of this virus.

**Tab. IV.** Mean reduction times at various inactivation percentages.

<i>ClO<sub>2</sub> – Hepatitis A virus – neutral pH</i>			
[ClO <sub>2</sub> ] (mg/l)	Mean time (min) to obtain reduction of:		
	99% (CI 95%)	99.9% (CI 95%)	99.99% (CI 95%)
0.80	0.26 *	0.35 *	0.43 *
0.60	0.53 (0.41-0.58)	0.85 (0.76-0.94)	1.45 (1.38-1.53)
0.40	2.35 (1.63-3.40)	6.79 (5.52-8.16)	19.58 (18.70-20.50)

\* It was impossible to calculate confidence limits values because of the very short viral inactivation time.

## References

- [1] Koopmans M, Duizer E. *Food viruses: an emerging problem*. Intern J Food Microbiol 2004;90:23-41.
- [2] Guzzella L, Monarca S, Zani C, Feretti D, Zerbini I, Buschini A, et al. *In vitro potential genotoxic effect of surface drinking water treated with chlorine and alternative disinfectants*. Mutation research 2004;564:179-93.
- [3] Sansebastiano G, Cesari C, Bellelli E. *Further investigation on water disinfection by chlorine dioxide*. Igiene Moderna 1986;85:358-80.
- [4] Sansebastiano G. *Epidemiological review on chlorine dioxide*. In: *Chlorine Dioxide and Disinfection*. Vol. 17. Milano: C.I.P.A. Publisher 1997, p. 63-71.
- [5] Ruzic C. *Chlorine dioxide-based water treatment in the food industry*. In: *Chlorine Dioxide and Disinfection*. Vol. 17. Milano: C.I.P.A. Publisher 1997, p. 197-209.
- [6] Aieta EM, Berg JB. *A review of chlorine dioxide in drinking water treatment*. JAWWA 1986;78:62-72.
- [7] Alvarez ME, O'Brien RT. *Mechanisms of inactivation of poliovirus by chlorine dioxide and iodine*. Appl Environ Microbiol 1982;44:1064-71.
- [8] Bernarde MA, Israel BM, Olivieri VP, Granstrom ML. *Efficiency of chlorine dioxide as a bactericide*. Appl Microbiol 1965;13:776-80.
- [9] Chen YS, Vaughn JM. *Inactivation of human and simian rotaviruses by chlorine dioxide*. Appl Environ Microbiol 1990;56:1363-6.
- [10] Latshaw CL. *Chlorine dioxide: effective broad-spectrum biocide for white-water systems*. Tappi Journal 1994;78:163-6.
- [11] Roller SD. *Some aspects of the mode of action of chlorine dioxide on Bacteria*. Baltimore: M.S. Thesis, Johns Hopkins University 1978.
- [12] Scarpino PV. *Virucidal effectiveness of disinfection processes-chlorine dioxide*. In: *Proceedings of the American Water Works Association, Annual Conference*. 1979, p. 1-35.
- [13] Traenhart O, Kuwert E. *Comparative studies on the action of chlorine and ozone on polioviruses in the reprocessing of drinking water in Essen*. Zbl Bakt I Abt Orig 1975;160:305.
- [14] Sansebastiano G, Mori G, Tanzi ML, Cesari C, Bellelli E. *Chlorine dioxide: methods of analysis and kinetics of inactivation of poliovirus type 1*. Igiene Moderna 1983;79:61-91.

■ Received on June 6, 2006. Accepted on March 28, 2007.

■ Correspondence: Prof G. Sansebastiano, Department of Public Health, Sec. Hygiene, University of Parma, Italy, via Volturmo 39, 43100 Parma, Italy

Article

## Impact of Chlorine Dioxide Gas Sterilization on Nosocomial Organism Viability in a Hospital Room

John J. Lowe <sup>1,\*</sup>, Shawn G. Gibbs <sup>1,†</sup>, Peter C. Iwen <sup>2,†</sup>, Philip W. Smith <sup>3,†</sup> and Angela L. Hewlett <sup>3,†</sup>

<sup>1</sup> Department of Environmental, Agricultural & Occupational Health, University of Nebraska Medical Center College of Public Health, Omaha, NE 68198, USA; E-Mail: sgibbs@unmc.edu

<sup>2</sup> Department of Pathology and Microbiology, University of Nebraska Medical Center College of Medicine, Omaha, NE 68198, USA; E-Mail: piwen@unmc.edu

<sup>3</sup> Section of Infectious Diseases, University of Nebraska Medical Center College of Medicine, Omaha, NE 68198, USA; E-Mails: pwsmith@unmc.edu (P.W.S.); alhewlett@unmc.edu (A.L.H.)

† These authors contributed equally to this work.

\* Author to whom correspondence should be addressed; E-Mail: jjlowe@unmc.edu; Tel.: +1-402-552-3001; Fax: +1-402-552-2769.

Received: 7 April 2013; in revised form: 3 June 2013 / Accepted: 10 June 2013 /

Published: 21 June 2013

---

**Abstract:** To evaluate the ability of ClO<sub>2</sub> to decontaminate pathogens known to cause healthcare-associated infections in a hospital room strains of *Acinetobacter baumannii*, *Escherichia coli*, *Enterococcus faecalis*, *Mycobacterium smegmatis*, and *Staphylococcus aureus* were spot placed in duplicate pairs at 10 sites throughout a hospital room and then exposed to ClO<sub>2</sub> gas. Organisms were collected and evaluated for reduction in colony forming units following gas exposure. Six sterilization cycles with varied gas concentrations, exposure limits, and relative humidity levels were conducted. Reductions in viable organisms achieved ranged from 7 to 10-log reductions. Two sterilization cycles failed to produce complete inactivation of organisms placed in a bathroom with the door closed. Reductions of organisms in the bathroom ranged from 6-log to 10-log reductions. Gas leakage between hospital floors did not occur; however, some minor gas leakage from the door of hospital room was measured which was subsequently sealed to prevent further leakage. Novel technologies for disinfection of hospital rooms require validation and safety testing in clinical environments. Gaseous ClO<sub>2</sub> is effective for sterilizing

environmental contamination in a hospital room. Concentrations of  $\text{ClO}_2$  up to 385 ppm were safely maintained in a hospital room with enhanced environmental controls.

**Keywords:** chlorine dioxide; sterilization; gas; nosocomial; hospital

---

## 1. Introduction

The Centers for Disease Control and Prevention (CDC) estimates that 1.7 million hospitalized patients develop a hospital-associated infection (HAI) each year in the United States. These infections account for \$4.5 to \$6.5 billion in excess healthcare costs in the U.S. each year [1]. Studies have demonstrated environmental contamination may be a risk factor for acquisition of hospital-associated pathogens [2–6]. Outbreak and terminal cleaning investigations involving bacterial and viral organisms have focused on the hospital environment as a potential source of transmission and environmental cleaning efforts have been shown to play an important role in control of these outbreaks [7–9]. Although routinely employed, manual application of liquid sterilization chemicals is time consuming, labor intensive and prone to errors, thus prompting investigations into alternative methods for environmental disinfection [10–12]. Application of fumigating agents and ultraviolet (UV) light technologies have been explored as alternatives to manual disinfection for entire rooms. Fumigating agents such as ozone and hydrogen peroxide vapor have been evaluated in clinical environments as well as UV technologies [13–15]. These studies evaluated the efficacy of non-manual methods in addition to manual cleaning to reduce bacterial capture from hospital surfaces often during an active HAI outbreak.

This study evaluates the ability of chlorine dioxide to reduce a variety of nosocomial organisms throughout a hospital room. Chlorine dioxide ( $\text{ClO}_2$ ) is an EPA-registered gaseous sterilant that was utilized to decontaminate federal buildings during the 2001 anthrax attacks [16,17]. As a gas,  $\text{ClO}_2$  is ideal for penetrating the small spaces found in patient care rooms. However, the significant relative humidity requirement for gaseous  $\text{ClO}_2$  decontamination with respect to bacterial spore inactivation may limit the benefit of penetrability, gaseous  $\text{ClO}_2$  has not been tested in the healthcare environment. This study evaluated the ability of gaseous  $\text{ClO}_2$  to decontaminate pathogens known to cause healthcare-associated infections on surfaces in a hospital room.

## 2. Experimental Section

### 2.1. Setting

A 20 m<sup>2</sup> hospital room in the Nebraska Biocontainment Patient Care Unit (NBPCU), located at the University of Nebraska Medical Center, was selected to test whole room disinfection using  $\text{ClO}_2$ . The rooms in this unit were chosen for evaluation because of the NBPCU's unique construction and safety features common to biosafety level 3 laboratories [18]. The NBPCU is at negative pressure with an average of 23 air exchanges per hour with controlled access making it ideal for testing potentially hazardous disinfection technologies.



## 2.2. Organisms

Eight organisms were selected to test ClO<sub>2</sub> sterilization in the hospital room: highly drug-resistant wild type *Acinetobacter baumannii* BC 9782, *Escherichia coli* ATCC 25922, *Escherichia coli* ATCC 51446, *Enterococcus faecalis* ATCC 29212, vancomycin-resistant *Enterococcus faecalis* ATCC 51299, *Mycobacterium smegmatis* ATCC 14468, *Staphylococcus aureus* ATCC 25323 and methicillin-resistant *Staphylococcus aureus* ATCC 43300. *Acinetobacter baumannii* BC 9782 is resistant to multiple classes of antimicrobial agents including all aminoglycosides, cephalosporins, fluoroquinolones, broad-spectrum penicillins, trimethoprim-sulfamethoxazole, and tetracycline, but is susceptible to carbapenems. Concentrated organism stocks,  $3 \times 10^{10}$  colony forming units/mL, were established using standard culturing methods for each organism [15,19–21]. Organism stock concentrations were measured using Siemens Microscan Turbidity Meter (Siemens Healthcare Diagnostics, Glasgow, DE, USA). Organism stocks were maintained at 4 °C for a maximum of 14 days.

The *A. baumannii* and *S. aureus* strains were grown on TSA plates and incubated at 37 °C for 24 h. *S. aureus* was incubated with 5% CO<sub>2</sub> and the *A. baumannii* was incubated at ambient air. Isolated colonies were then inoculated into 100 mL of TSB and incubated at 37 °C for 24 h. The broth culture was then washed by centrifugation twice using dH<sub>2</sub>O. Following the second centrifugation, the pellet was diluted in phosphate buffer saline PBS and adjusted to concentration.

Both *E. coli* and *E. faecalis* were prepared on brain heart infusion (BHI, Remel Labs, Lenexa, KS, USA) agar plates and incubated at 37 °C for 24 h. Isolated colonies were used to inoculate 100 mL BHI broth and incubated at 37 °C for 24 h. Liquid cultures were twice centrifuged to pellet cells and washed with dH<sub>2</sub>O. Following the second centrifugation, the pellet was diluted in phosphate buffer saline PBS and adjusted to concentration.

The *M. smegmatis* strain was grown on TSA plates containing 5% sheep blood (S-TSA) and incubated at 37 °C with 5% CO<sub>2</sub> for 24 h. Isolated colonies were inoculated into 100 mL TSB containing 5% sheep blood and incubated at 37 °C with 5% CO<sub>2</sub> for 24 h. Broth cultures were twice centrifuged to pellet cells and washed with dH<sub>2</sub>O. Pellets were diluted in PBS and adjusted to concentration.

Commercially prepared *Bacillus atrophaeus* ATCC 9372 spore strip (Raven Labs, Omaha, NE, USA) biological indicators were also used to validate ClO<sub>2</sub> decontaminations. *Bacillus atrophaeus* spore strip biological indicators are the standard for ClO<sub>2</sub> decontamination validation. Each biological indicator strip was impregnated with a median value of 10<sup>6</sup> spores and was contained in sterile Tyvek envelopes for aseptic processing. A 300 µL volume of each organism stock was pipetted into an empty well of a quad plate and transported to the hospital room in a hard sided container. Organism duplicate pairs were placed at 10 locations (Table 1, Figure 1) in the hospital room to assess complete gas penetration and one location in a control room. Control organisms were processed identically to exposure organisms. Log reductions were calculated from comparison of concentrations of control and exposure samples. Control and exposure concentrations were measured by serial dilution plate counts.

**Table 1.** Organism spot placement sites utilized for hospital room chlorine dioxide environmental decontamination evaluation.

Site #	Description	Meters from:		
		Injection Site	Floor	Ceiling
1	Floor next to injection tubing	0.3	0.0	3.3
2	Small wall mounted countertop	1.3	1.0	2.3
3	On top of bed mattress	1.6	1.3	2.0
4	Floor	2.7	0.0	3.3
5	Between wall mounted TV and VCR	3.0	2.3	1.0
6	Top of sink in bathroom	3.3	1.3	2.0
7	Inside metal cabinet	3.7	1.0	2.3
8	On window countertop	4.0	1.3	2.0
9	Top of wall mounted light fixture	4.3	2.7	0.7
10	Top of wall mounted light fixture	5.3	2.7	0.7

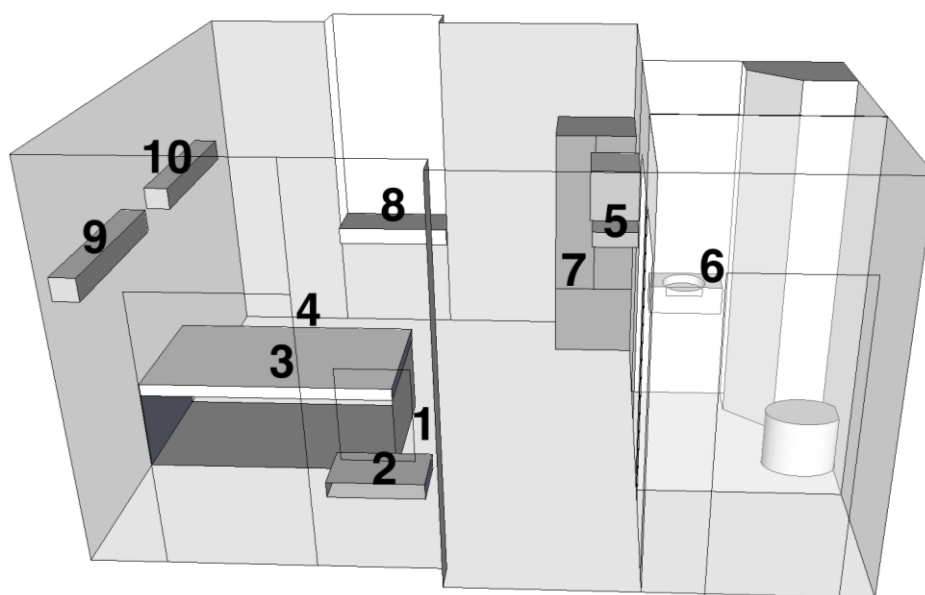
**Figure 1.** Organism spot placement sites utilized for hospital room chlorine dioxide environmental decontamination evaluation.

### 2.3. Chlorine Dioxide Sterilization

A total of six sterilization cycles were evaluated in the hospital room. Prior to each cycle the hospital room was sealed with duct tape and plastic sheeting from the outside to limit gas leakage into the hallway and adjacent rooms. The ClO<sub>2</sub> generator, Minidox-M Decontamination System (Clordisys Solutions, Inc. Lebanon, NJ, USA), was placed in the hallway as a precaution to mitigate potential ClO<sub>2</sub> leakage and two polyvinylidene fluoride tube lines were placed from the generator into the room through the space under the entry door. The tube lines allowed delivery of ClO<sub>2</sub> gas into the room and air sampling of the room to monitor gas concentrations. Gas concentrations inside the room were continuously monitored by the generator. Two personnel were required at all times during the sterilization process to monitor the generator, adjacent areas and floors for leaks. Once the sterilization procedure was complete, the ClO<sub>2</sub> gas was then evacuated from the hospital room using two activated

charcoal scrubbers. One scrubber was operated inside the hospital room and one scrubber was located in the adjacent hallway.

#### 2.4. Safety Considerations

Study personnel carried fit-tested full-face respirators equipped with acid gas filters. Adjacent areas and floors were continuously monitored for ClO<sub>2</sub> gas with a hand held Portasens II detector (Analytical Technology, Inc. Oaks, PA, USA) with a calibrated detection range of 0–5 ppm, accuracy of ±5% and sensitivity of 1% for the sensor (00-1005) and model used (C16-1). The exhaust air system servicing the unit and the treated room was kept operational at all times. Inside the sterilization room the exhaust dampers were sealed but could be opened to allow rapid evacuation of the ClO<sub>2</sub> gas in the event of an emergency.

Initially chlorine dioxide gas (0.1 ppm) was measured in the adjacent hallway directly in front of the treated room. The seal around the entry door to the room was adjusted and a safe zone was established 3 meters from the door. Gas monitoring of the hospital floor below the NBPCU treated room was conducted and no ClO<sub>2</sub> gas was detected.

#### 2.5. Sterilization Parameters

Six separate sterilization cycles were performed and ClO<sub>2</sub> concentrations of 351 ppm to 385 ppm (Table 2) were maintained in the hospital room for <3 h with no impact on areas outside the unit. Relative humidity was raised and maintained to 50% and 65% and maintained for 30 min prior to each sterilization cycle using a portable steamer controlled from outside the room. Chlorine dioxide exposures of 677 ppm-h to 890 ppm-h were achieved in the hospital room. Four sterilization cycles were performed with the interior hospital room doors, the bathroom door, and the cabinet door open. Two cycles evaluated the impact of closed bathroom and cabinet doors on sterilization.

#### 2.6. Organism Processing

Following completion of each sterilization cycle and reduction of ClO<sub>2</sub> gas in the room to 0 parts per million, test and control organisms were retrieved from placement sites and transported in a hard sided container to a biosafety level 2 laboratory for processing. Organisms were collected from quad plates using standard swabbing technique previously reported and swabs were transferred to 700 µL phosphate buffer saline (PBS) [22,23]. PBS swab solutions were serially diluted, plated onto culture media, incubated, and evaluated for colony forming unit plate counts. Log reduction in viable organisms exposed to ClO<sub>2</sub> was assessed through comparison of serial dilution plate counts of the non-exposed control organisms. Control samples were processed using the same protocols as exposure samples. Geometric mean log reductions and percent inactivation were calculated for each organism. Statistical significance was not calculated as complete inactivation for all or most samples of each organism resulted in limited variance. Complete inactivation allows scrutiny of growth or no growth of specimens at placement sites to distinguish differences between treatment protocols. For these reasons log reduction results are reported as mean log reduction of all 10 sites throughout the room to indicate overall penetration of ClO<sub>2</sub> throughout the hospital room.

**Table 2.** Organism inactivation following exposure to chlorine dioxide gas in a hospital environment.

ClO <sub>2</sub> Conc. (ppm)	Exposure (ppm-h)	% RH	Mean Log Reduction (% inactivation) of all 10 placement sites <sup>†</sup>							
			<i>A. baumannii</i> HDR BC 9782	<i>E. coli</i> ATCC 25922	<i>E. coli</i> ATCC 51446	<i>E. faecalis</i> ATCC 29212	<i>E. faecalis</i> ATCC 51295	<i>M. smegmatis</i> ATCC 14468	<i>S. aureus</i> ATCC 25323	<i>S. aureus</i> ATCC 43300
351	677	50	9.03 (100%)	9.96 (100%)	10.00 (100%)	10.1 (100%)	9.96 (100%)	10.0 (100%)	8.48 (100%)	9.04 (100%)
377	890	65	7.65 (100%)	8.66 (100%)	9.13 (100%)	8.28 (100%)	9.06 (100%)	8.91 (100%)	7.41 (100%)	8.27 (100%)
379	767	65	9.33 (100%)	9.02 (100%)	9.35 (100%)	9.40 (100%)	9.21 (100%)	9.22 (100%)	8.41 (100%)	8.69 (100%)
385	770	65	8.24 (100%)	8.93 (100%)	9.03 (100%)	8.03 (100%)	9.04 (100%)	9.08 (100%)	8.37 (100%)	8.54 (100%)
376	788	64	8.04 (98%)	8.93 (98%)	9.01 (98%)	8.24 (99%)	9.24 (97%)	8.97 (99%)	8.42 (99%)	8.06 (98%)
378	781	66	9.02 (98%)	9.75 (97%)	9.71 (97%)	10.07 (100%)	9.82 (98%)	9.76 (97%)	9.90 (99%)	9.93 (99%)

<sup>†</sup> Site No. 6 was the only placement site with growth following ClO<sub>2</sub> exposure.

### 3. Results and Discussion

Sterilization cycles 1, 2, 3 and 4 achieved complete inactivation of duplicate pairs of *A. baumannii*, *E. coli*, *E. faecalis*, *M. smegmatis* and *S. aureus* as well as *B. atrophaeus* spores at all 10 placement sites throughout the hospital room (Table 2). This resulted in a 7.4 log to 10.1 log reduction in viable counts.

Sterilization cycles 5 and 6 (Table 2), evaluating the impact of closed doors within the hospital room completely inactivated all test organisms and spore strip indicators (Table 3) at placement sites within the primary area of the hospital room, but did not result in complete inactivation of organisms or indicators at placement site 6, which was located on the sink in the hospital room bathroom. Despite the lack of complete inactivation, a >6 log reduction of each organism was achieved in spite of the closed doors (Table 2). Of note, complete inactivation was observed for all organisms and spore strip indicators (Table 3) at placement site 7 located inside a closed metal cabinet.

**Table 3.** *Bacillus atrophaeus* biological indicator inactivation following exposure to chlorine dioxide gas.

ClO <sub>2</sub> Conc. (ppm)	Exposure (ppm-h)	% RH	<i>B. atrophaeus</i> spores	
			No. of sites with growth	No. of sites without growth
351	677	50	0	10
377	890	65	0	10
379	767	65	0	10
385	770	65	0	10
376	788	64	1	9
378	781	66	1	9

The importance of the hospital environment in the transmission of pathogens associated with healthcare infections has been demonstrated and emphasizes the need for adequate methods for room disinfection [2–9]. Other modalities of decontamination, including ozone and hydrogen peroxide vapor to reduce nosocomial organisms in the hospital environment have also been evaluated [10–15,24–29]. Moat *et al.* found ozone capable of producing up to 3 log reduction of *Clostridium difficile*, *Escherichia coli*, *Staphylococcus aureus*, and *Enterococcus faecalis* in a laboratory chamber and a mock hospital room [24]. Berrington and Pedler observed that ozone decontamination in a hospital room reduced levels of MRSA contamination in close proximity to the ozone generator, but failed to produce reduction in viable bacteria at contamination sites located away from the generator [25]. French *et al.* compared the reduction of MRSA environmental contamination following manual environmental cleaning with solution of detergent sanitizer GWP 4L (GWP Group, Elland, W. Yorkshire, UK) and hydrogen peroxide vapor fumigation throughout a hospital in a study co-published with Bioquell (Hampshire, UK) [11]. Environmental levels of MRSA contamination prior to manual cleaning with detergent solution were identified at 70% of tested sites and remained at 66% of test sites following manual cleaning and 1.2% of sites following hydrogen peroxide fumigation. Of note, French observed 100% inactivation of 10<sup>6</sup> *Bacillus stearothermophilus* spores from a biological indicator for gaseous decontamination. Persistence of environmental MRSA despite no growth results from 10<sup>6</sup> biological indicators suggest commercially available biological indicators

may not provide adequate validation compared to environmental sampling to confirm complete reduction of environmental contamination. A variety of parameters should be considered when choosing a decontamination technique, including organism concentration, contamination of varied surfaces, the presence of wet contaminated surfaces, organic contamination, and the presence of organic soil.

#### 4. Conclusions

This study provides evidence that ClO<sub>2</sub> gas can be used to effectively eliminate environmental bacterial contamination in the healthcare setting. Limitations of this pilot study include that engineering controls of the NBPCU hospital room were more robust than a standard hospital room. By design, the clinical setting chosen for this assessment maximized safety measures. These additional safety measures may not apply in a non-BPCU setting with rooms that are not separately sealed and do not have the capability to rapidly evacuate gas if needed. ClO<sub>2</sub> has a permissible exposure limit of 0.1 ppm and a short term exposure limit of 0.3 ppm set by the U.S. Occupational Safety and Health Administration (OSHA). Chlorine dioxide gas produces mucosal eye and respiratory irritation at concentration levels of 5 ppm. Any usage of ClO<sub>2</sub> should also be undertaken after a careful safety analysis, as was done in this study. In spite of these limitations, this study demonstrates that ClO<sub>2</sub> may provide a viable option for decontamination of bacterial organisms. Further studies are necessary to validate the utility of gaseous ClO<sub>2</sub> as an infection control modality in the healthcare setting.

#### Acknowledgments

We also thank Kevin Lorcheim of ClorDiSys Solutions for technical support and providing some equipment. *Financial support.* This work was supported by the Nebraska Patient Care Biocontainment Unit at the Nebraska Medical Center. Additionally, the Minidox-M Decontamination System was on loan to the research group from ClorDiSys Solutions. However, ClorDiSys was not part of the research team, party to experimental design, or aware of the results of this article. ClorDiSys put no conditions on the use of the Minidox system beyond that it be returned.

#### Conflict of Interest

The authors declare no conflict of interest.

#### References

1. Klevens, R.M.; Edwards, J.R.; Richards, C.L.; Horan, T.C.; Gaynes, R.P.; Pollock, D.A.; Cardo, D.M. Estimating health care-associated infections and deaths in US hospitals, 2002. *Public Health Rep.* **2007**, *122*, 160–166.
2. Martinez, J.A.; Ruthazer, R.; Hansjosten, K.; Barefoot, L.; Snyderman, D.R. Role of environmental contamination as a risk factor for acquisition of vancomycin-resistant enterococci in patients treated in a medical intensive care unit. *Arch. Intern. Med.* **2003**, *163*, 1905–1912.
3. Ray, A.J.; Hoyer, C.K.; Taub, T.F.; Eckstein, E.C.; Donskey, C.J. Nosocomial transmission of vancomycin-resistant enterococci from surfaces. *JAMA* **2002**, *287*, 1400–1401.

4. Boyce, J.M.; Potter-Bynoe, G.; Chenevert, C.; King, T. Environmental contamination due to methicillin-resistant *Staphylococcus aureus*: Possible infection control implications. *Infect. Control. Hosp. Epidemiol.* **1997**, *18*, 622–627.
5. Hardy, K.J.; Oppenheim, B.A.; Gossain, S.; Gao, F.; Hawkey, P.M. A study of the relationship between environmental contamination with methicillin-resistant *Staphylococcus aureus* (MRSA) and patients' acquisition of MRSA. *Infect. Control. Hosp. Epidemiol.* **2006**, *27*, 127–132.
6. Huang, S.S.; Datta, R.; Platt, R. Risk of acquiring antibiotic-resistant bacteria from prior room occupants. *Arch. Intern. Med.* **2006**, *166*, 1945–1951.
7. Falk, P.S.; Winnike, J.; Woodmansee, C.; Desai, M.; Mayhall, C.G. Outbreak of vancomycin-resistant enterococci in a burn unit. *Infect. Control Hosp. Epidemiol.* **2000**, *21*, 575–582.
8. Rampling, A.; Wiseman, S.; Davis, L.; Hyett, A.P.; Walbridge, A.N.; Payne, G.C.; Cornaby, A.J. Evidence that hospital hygiene is important in the control of methicillin-resistant *Staphylococcus aureus*. *J. Hosp. Infect.* **2001**, *49*, 109–116.
9. Aygun, G.; Demirkiran, O.; Utku, T.; Mete, B.; Urkmez, S.; Yilmaz, M.; Yasar, H.; Dikmen, Y.; Ozturk, R. Environmental contamination during a carbapenem-resistant *Acinetobacter baumannii* outbreak in an intensive care unit. *J. Hosp. Infect.* **2002**, *52*, 259–262.
10. Boyce, J.M.; Havill, N.L.; Otter, J.A.; McDonald, L.C.; Adams, N.M.; Cooper, T.; Thompson, A.; Wiggs, L.; Killgore, G.; Tauman, A.; Noble-Wang, J. Impact of hydrogen peroxide vapor room decontamination on *Clostridium difficile* environmental contamination and transmission in a healthcare setting. *Infect. Control Hosp. Epidemiol.* **2008**, *29*, 723–729.
11. French, G.L.; Otter, J.A.; Shannon, K.P.; Adams, N.M.; Watling, D.; Parks, M.J. Tackling contamination of the hospital environment by methicillin-resistant *Staphylococcus aureus* (MRSA): A comparison between conventional terminal cleaning and hydrogen peroxide vapour decontamination. *J. Hosp. Infect.* **2004**, *57*, 31–37.
12. Andersen, B.; Rasch, M.; Hochlin, K.; Jensen, F.H.; Wismar, P.; Fredriksen, J.E. Decontamination of rooms, medical equipment and ambulances using an aerosol of hydrogen peroxide disinfectant. *J. Hosp. Infect.* **2006**, *62*, 149–155.
13. Umezawa, K.; Asai, S.; Inokuchi, S.; Miyachi, H. A comparative study of the bactericidal activity and daily disinfection housekeeping surfaces by a new portable pulsed UV radiation device. *Curr. Microbiol.* **2012**, *64*, 581–587.
14. Clark, J.; Barrett, S.P.; Rogers, M.; Stapleton, R. Efficacy of super-oxidized water fogging in environmental decontamination. *J. Hosp. Infect.* **2006**, *64*, 386–390.
15. Rastogi, V.K.; Wallace, L.; Smith, L.S. Disinfection of *Acinetobacter baumannii*-contaminated surfaces relevant to medical treatment facilities with ultraviolet C light. *Mil. Med.* **2007**, *172*, 1166–1169.
16. Canter, D.A.; Gunning, D.; Rodgers, P.; O'Connor, L.; Traunero, C.; Kempter, C.J. Remediation of *Bacillus anthracis* contamination in the US Department of Justice mail facility. *Biosecur. Bioterror.* **2005**, *3*, 119–127.
17. Barth, E.; Rupert, R.; Stroud, F.; Rice, E.; Potoka, B. Environmental response to intentional dissemination of *Bacillus anthracis* spores in the United States—2001. *Remediat. J.* **2003**, *13*, 99–111.

18. Smith, P.W.; Anderson, A.O.; Christopher, G.W.; Cieslak, T.J.; Devreede, G.J.; Fosdick, G.A.; Greiner, C.B.; Hauser, J.M.; Hinrichs, S.H.; Huebner, K.D.; *et al.* Designing a biocontainment unit to care for patients with serious communicable diseases: A consensus statement. *Biosecur. Bioterror.* **2006**, *4*, 351–365.
19. Brown, B.A.; Springer, B.; Steingrube, V.A.; Wilson, R.W.; Pfyffer, G.E.; Garcia, M.J.; Menendez, M.C.; Rodriguez-Salgado, B.; Jost, K.C., Jr.; Chiu, S.H. *Mycobacterium wolinskyi* sp. nov. and *Mycobacterium goodii* sp. nov., two new rapidly growing species related to *Mycobacterium smegmatis* and associated with human wound infections: A cooperative study from the International Working Group on Mycobacterial Taxonomy. *Int. J. Syst. Evol. Microbiol.* **1999**, *49*, 1493–1511.
20. Obee, P.; Griffith, C.; Cooper, R.; Bennion, N. An evaluation of different methods for the recovery of methicillin-resistant *Staphylococcus aureus* from environmental surfaces. *J. Hosp. Infect.* **2007**, *65*, 35–41.
21. Wright, J.B.; Lam, K.; Burrell, R.E. Wound management in an era of increasing bacterial antibiotic resistance: A role for topical silver treatment. *Am. J. Infect. Control* **1998**, *26*, 572–577.
22. Smith, P.W.; Gibbs, S.; Sayles, H.; Hewlett, A.; Rupp, M.E.; Iwen, P.C. Observations on hospital room contamination testing. *Healthc. Infect.* **2013**, *18*, 10–13.
23. Murray, P.; Baron, E.; Jorgensen, J.; Landry, M.; Tenover, M.; Tenover, M. *Manual of Clinical Microbiology*; ASM Press: Washington, DC, USA, 2007.
24. Moat, J.; Cargill, J.; Shone, J.; Upton, M. Application of a novel decontamination process using gaseous ozone. *Can. J. Microbiol.* **2009**, *55*, 928–933.
25. Berrington, A.W.; Pedler, S.J. Investigation of gaseous ozone for MRSA decontamination of hospital side-rooms. *J. Hosp. Infect.* **1998**, *40*, 61–65.
26. Chan, P.C.; Huang, L.M.; Lin, H.C.; Chang, L.Y.; Chen, M.L.; Lu, C.Y.; Lee, P.I.; Chen, J.M.; Lee, C.Y.; Pan, H.J.; Wang, J.T.; Chang, S.C.; Chen, Y.C. Control of an outbreak of pandrug-resistant *Acinetobacter baumannii* colonization and infection in a neonatal intensive care unit. *Infect. Control. Hosp. Epidemiol.* **2007**, *28*, 423–429.
27. Frieden, T.R.; Munsiff, S.S.; Low, D.E.; Willey, B.M.; Williams, G.; Faur, Y.; Eisner, W.; Warren, S.; Kreiswirth, B. Emergence of vancomycin-resistant enterococci in New York City. *Lancet* **1993**, *342*, 76–79.
28. Lai, K.K.; Kelley, A.L.; Melvin, Z.S.; Belliveau, P.P.; Fontecchio, S.A. Failure to eradicate vancomycin-resistant enterococci in a university hospital and the cost of barrier precautions. *Infect. Control. Hosp. Epidemiol.* **1998**, *19*, 647–652.
29. Noble, M.A.; Isaac-Renton, J.L.; Bryce, E.A.; Roscoe, D.L.; Roberts, F.J.; Walker, M.; Scharf, S.; Walsh, A.; Altamirano-Dimas, M.; Gribble, M. The toilet as a transmission vector of vancomycin-resistant enterococci. *J. Hosp. Infect.* **1998**, *40*, 237–241.



# Demonstrating that chlorine dioxide is a size-selective antimicrobial agent and high purity ClO<sub>2</sub> can be used as a local antiseptic

Zoltán Noszticzius, Maria Wittmann<sup>✉</sup>, Kristóf Kály-Kullai

Group of Chemical Physics, Department of Physics, Budapest University of Technology and Economics, Budapest, Hungary

<sup>✉</sup> wittmann@eik.bme.hu

Zoltán Beregvári

Jósa András Hospital, Nyíregyháza, Hungary

István Kiss

St. Imre Hospital, Budapest, Hungary

László Rosivall

Semmelweis University, Budapest, Hungary

János Szegedi

Jósa András Hospital, Nyíregyháza, Hungary

## Abstract

### Background / Aims

ClO<sub>2</sub>, the so-called “ideal biocide”, could also be applied as an antiseptic if it was understood why the solution’s rapid killing of microbes does not cause any harm to humans or to animals.

Our aim was to study both theoretically and experimentally its reaction-diffusion mechanism to find the source of that selectivity.

### Methods

ClO<sub>2</sub> permeation measurements through protein membranes were performed and the time delay of ClO<sub>2</sub> transport due to reaction and diffusion was determined. To calculate ClO<sub>2</sub> penetration depths and estimate bacterial killing times, approximate solutions of the reaction-diffusion equation were derived. Additionally, as a preliminary test, three patients with infected wounds were treated with a 300 ppm high purity ClO<sub>2</sub> solution and the healing process was documented.

### Results

The rate law of the reaction-diffusion model predicts that the killing time is proportional to the square of the characteristic size (e.g. diameter) of a body, thus, small ones will be killed extremely fast. For example, the killing time for a bacterium is on the order of milliseconds in a 300 ppm ClO<sub>2</sub> solution. Thus, the few minutes of contact time (owing to the volatility of ClO<sub>2</sub>) is quite enough to kill all bacteria, but short enough to keep ClO<sub>2</sub> penetration into the living tissues safely below 0.1 mm, minimizing cytotoxic effects. Pictures of successful wound healings confirm these considerations. Various properties of ClO<sub>2</sub>, advantageous for an antiseptic, are also discussed. Most importantly, bacteria are not able to develop resistance against ClO<sub>2</sub> as it reacts with biological thiols which play a vital role in all living organisms.

### Conclusion

Selectivity of ClO<sub>2</sub> between humans and bacteria is based not on their different biochemistry, but on their different size. Preliminary clinical results encourage further research with this promising local antiseptic.

**Funding:** This work was supported by OTKA Grant 77908.

**Competing interests:** Three of the authors, namely Zoltán Noszticzius, Maria Wittmann and Kristóf Kály-Kullai declare competing financial interest as they are co-inventors of the European patent 2069232 “Permeation method and apparatus for preparing fluids containing high purity chlorine dioxide”, see also reference 13. In addition Zoltán Noszticzius is also a founder of the Solumium Ltd. The other four authors have no competing financial interest.

## Introduction

The emergence and dissemination of new antibiotic-resistant bacterial strains caused by an overuse of antibiotics [1] is a global public-health concern. Methicillin Resistant Staphylococcus aureus (MRSA) [1], [2] and Carbapenem- or Extreme Drug-Resistant Acinetobacter baumannii [3], [4] are only two well known examples for such bacteria attracting world wide attention. Moreover, while the number of antibiotic resistant infections is on the rise, the number of new antibiotics is declining [1], [2]. As a result of such a dangerous situation, searches for new antimicrobial agents, as well as strategies including a switch from antibiotic to antiseptic therapies, whenever that is feasible, have been initiated.

When treating local infections of wounds, ulcers or an infected mucous membrane, the application of antiseptics instead of antibiotics is a reasonable alternative especially because bacteria are less able to develop resistance against them [5]. Presently the majority of the antiseptics used for wounds [6] are organic compounds. The most frequently applied ones [6] are chlorhexidine (chlorhexidine digluconate), octenidine (octanidine dihydrochloride), polyhexanide (polyhexamethylene biguanide) and triclosan (5-chlorine-2-(2,4-dichlorphenoxy)-phenol). Notable exceptions are PVP-iodine (poly(vinylpyrrolidone)-iodine complex) [6] where the active ingredient is iodine, and silver [7], both being inorganic compounds.

There are some other, less used, inorganic antiseptics such as aqueous sodium hypochlorite (NaOCl), or hydrogen peroxide (H<sub>2</sub>O<sub>2</sub>) solutions, or ozone (O<sub>3</sub>) gas which have some applications in dentistry [8]. These compounds, however, are mainly used as disinfectants because they can be toxic even in low concentrations, a property seriously limiting their antiseptic applications. NaOCl, for example, one of the most commonly used components of irrigating solutions in endodontic practice, can cause poisoning and extensive tissue destruction if it is injected (inadvertently) into periapical tissues in the course of endodontic therapy [9]. H<sub>2</sub>O<sub>2</sub> is also a double edged sword against bacteria as it also hurts living tissue [10]. Moreover, many bacteria are able to resist H<sub>2</sub>O<sub>2</sub> as their catalase enzyme is able to decompose H<sub>2</sub>O<sub>2</sub> rapidly [11]. Thus, beside toxicity, resistance can be also a problem even with the use of inorganic disinfectants [5]. It would be therefore reasonable to choose an antiseptic which would be free of such problems. We believe that in this respect chlorine dioxide (ClO<sub>2</sub>) may be the right choice, moreover ClO<sub>2</sub> has other characteristic features favourable for antiseptic applications.

In the last twenty or more years chlorine dioxide emerged as a new and popular inorganic disinfectant. It is often referred to as „the ideal biocide” [12] because of its advantageous properties. In spite of that, as far as we know, ClO<sub>2</sub> solutions are not frequently used as antiseptic. This is because the available ClO<sub>2</sub> solutions were more or less contaminated with other chemicals applied in its synthesis and that contamination formed a major obstacle in medical applications

like treating infected wounds, for example. Since 2006, however, with the help of an invention [13], it is relatively easy to produce high purity aqueous  $\text{ClO}_2$  solutions. These solutions are already commercially available [14] and have been successfully used in dentistry [15] since 2008. Thus, it seems reasonable to ask the question whether the „ideal biocide” in its pure form can also be an „ideal local antiseptic” at the same time.

Such an ideal local antiseptic should satisfy many criteria. First of all, it should be safe: it should act only locally to avoid the danger of systemic poisoning and should not inflict cytotoxic effects even in the disinfected area. In this respect, it is one of the main aims of the present work to find a reasonable answer for the following intriguing question: **how is it possible that contacting or even drinking  $\text{ClO}_2$  solution is practically harmless for animals [16] and human beings [17], while the same aqueous solution can be a very effective and a rapid killer for bacteria, fungi, and viruses?** What is the basis of this unexpected selectivity?

The answer suggested in the Results section is the following: the selectivity between humans or animals and microbes is based not on their different biochemistry, but on their different size. **Denominating  $\text{ClO}_2$  in the title as a „size selective” antimicrobial agent aims to emphasize this new type of selectivity.** To reach that conclusion,  $\text{ClO}_2$  transport was studied experimentally via protein membranes. The results of these experiments were evaluated applying a reaction-diffusion model for the  $\text{ClO}_2$  transport in a reactive medium to obtain the diffusion coefficient of  $\text{ClO}_2$ , and the concentration of reactive groups in a protein medium. Based on these parameters the killing time, the time needed to flood a bacterium completely with  $\text{ClO}_2$ , can be calculated. (Details of the reaction-diffusion model and the derivation of formulae estimating the killing time are given in the Supplementary material.) It was found that the characteristic time necessary to kill a microbe is only a few milliseconds. As  $\text{ClO}_2$  is a rather volatile compound its contact time (its staying on the treated surface) is limited to a few minutes. While this stay is safely long enough (being at least 3 orders of magnitude longer than the killing time) to inactivate all bacteria on the surface of the organism, it is too short for  $\text{ClO}_2$  to penetrate deeper than few tenths of a millimetre; thus, it cannot cause any real harm to an organism which is much larger than a bacterium.

To show that these ideas can be applied in medical practice, we present some preliminary results of successful treatments of non-healing wounds with a high purity  $\text{ClO}_2$  solution.

In the Discussion part, it is shown that  $\text{ClO}_2$  can meet the safety and effectiveness requirements for a local antiseptic. Next, the chemical mechanism of the antiseptic action of  $\text{ClO}_2$  is discussed and compared with that of hypochlorous and hypoiodous acids ( $\text{HOCl}$  and  $\text{HOI}$ ) which are „natural” antiseptics. These hypohalous acids are used by neutrophil granulocytes, the most abundant type of white blood cells in mammals, to kill bacteria after phagocytosis. Both hypohalous acids and also  $\text{ClO}_2$  attack sulfhydryl groups which play an essential role in the life processes of all living systems, e.g. in ATP synthesis [18]. That explains why bacteria were not able to develop resistance against  $\text{HOCl}$  during eons of evolution and why the emergence of  $\text{ClO}_2$  resistant bacterial strains cannot be expected either. Besides this similarity, however, there are also important dissimilarities among these reagents, e.g.  $\text{ClO}_2$  is more selective than  $\text{HOCl}$ . Last of all, circulation in multicellular organisms can provide some additional protection to these organisms against  $\text{ClO}_2$ .

## Methods

### Physico-chemical methods

#### Measurement of ClO<sub>2</sub> permeation through protein membranes

The rate of ClO<sub>2</sub> transport was measured with the apparatus shown in Fig. 1 through two kinds of protein membranes: gelatin and pig bladder membranes, respectively. Choosing a membrane geometry for the experiments is advantageous because then the problem is „one dimensional”, the concentration is a function of only one spatial coordinate  $x$ , which is perpendicular to the membrane, and the concentration distribution can be given as  $c=c(x,t)$ .

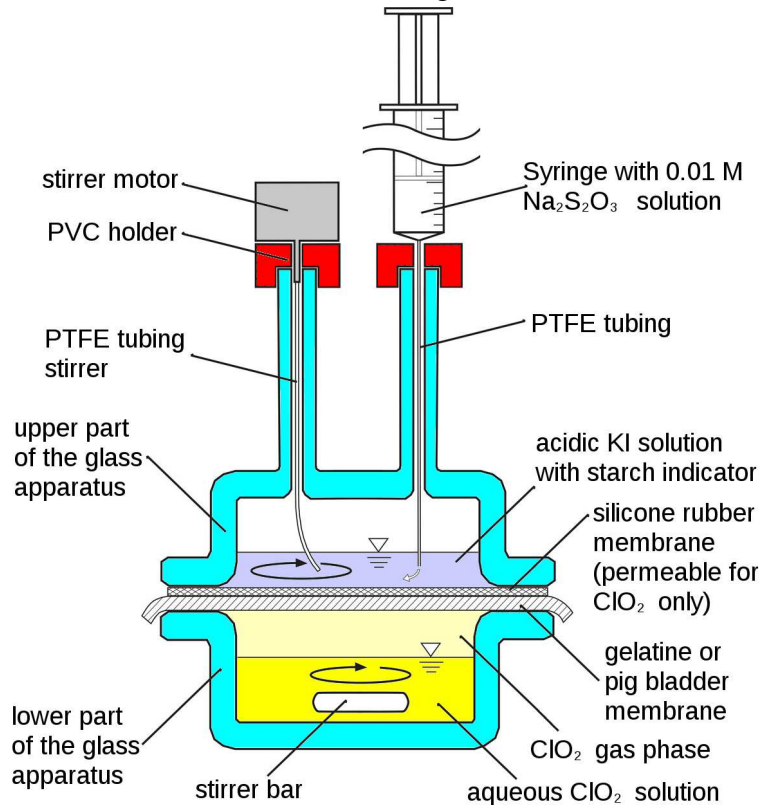

**Figure 1.** Apparatus to measure ClO<sub>2</sub> transport through gelatine or pig bladder membranes.

The two glass parts of the apparatus are held together by a pair of extension clamps (not shown in the Figure) which are fixed to a support stand by clamp holders. The active cross-section of the membranes is 28 cm<sup>2</sup>. See text for the working principle.

As Fig. 1 shows, the membrane is in a horizontal position and the transport of ClO<sub>2</sub> takes place across the membrane bounded by two horizontal planes we denote by  $x=0$  and  $x=d$  in our calculations, where  $d$  is the thickness of the membrane.

Constant ClO<sub>2</sub> concentrations are maintained at both boundaries of the membrane, i.e. we have constant boundary conditions:  $c(0,t)=c_0$  and  $c(d,t)=0$ , respectively. There is no ClO<sub>2</sub> in the membrane at the start of the experiment, so the initial condition:  $c(0 < x \leq d, 0)=0$  (see Supplemental Figure S1).

While the lower face of the protein membrane is not in direct contact with the liquid phase, such direct contact would not make any difference regarding the  $\text{ClO}_2$  transport. This is because the chemical potential of  $\text{ClO}_2$  in the liquid and the vapour phase is the same due to the equilibrium between the liquid and the vapour phase established by continuous stirring.

Above the protein membrane there is a silicone rubber membrane in order to block the transport of any other chemicals except  $\text{ClO}_2$ . Silicone rubber is highly permeable for chlorine dioxide, but it is practically impermeable for other reagents [13]. This way the  $\text{ClO}_2$  transport across the test membrane can be measured selectively.

Both protein membranes had a thickness of 0.5 mm and a diameter of 10 cm. The diameter of the active area in the apparatus was 6 cm resulting in an active area of  $28 \text{ cm}^2$ . The volume of the aqueous  $\text{ClO}_2$  solution was 40 ml and its  $\text{ClO}_2$  concentration was around 1000 ppm. (The exact value is given at each experiment.)

After crossing the membranes,  $\text{ClO}_2$  enters the upper aqueous solution which is made by mixing 10 ml of water, 2 ml of 1 M sulphuric acid, 1 ml of 1 M KI, and 0.5 ml of 0.01 M  $\text{Na}_2\text{S}_2\text{O}_3$  and as an indicator, two drops of 5 % starch solution is also added. When  $\text{ClO}_2$  enters the upper solution, it oxidizes iodide to iodine, which, in turn, is reduced back to iodide again by  $\text{Na}_2\text{S}_2\text{O}_3$  as long as thiosulphate is in excess. However, when all thiosulphate is consumed, the intense blue-black colour of the starch-triiodide complex appears suddenly. The time  $t$  when the whole solution becomes homogeneously black (the time of the „black burst”) was recorded and another 0.5 ml of  $\text{Na}_2\text{S}_2\text{O}_3$  solution was added with the help of the syringe shown in the Figure. Addition of the thiosulphate eliminated the blue-black colour immediately but, after a certain period, when enough new  $\text{ClO}_2$  was transported across the membrane, it reappeared again. Then the cycle was repeated starting with the injection of a new 0.5 ml portion of the  $\text{Na}_2\text{S}_2\text{O}_3$  solution. The results of the measurements were depicted in a  $V=V(t)$  diagram where  $t$  is the time of the  $n$ -th dark burst and  $V = n \times 0.5 \text{ ml}$  that is the total volume of the thiosulphate solution added before the  $n$ -th breakthrough.

The experiments were performed at laboratory temperature  $24 \pm 2 \text{ }^\circ\text{C}$ .

#### **Preparation of the gelatin membrane**

To prepare a mechanically strong membrane, it was reinforced by filter paper and the gelatin was cross-linked with glutaraldehyde. As the cellulose in the filter paper does not react with  $\text{ClO}_2$  from the point of our experiments, it is an inert material.

10 ml of 10 % aqueous gelatin solution was mixed rapidly with 0.5 ml of 25 % glutaraldehyde solution at room temperature, and a filter paper disk (diameter: 10 cm) was soaked with the mixture. Then the disk was placed between two glass plates covered with polyethylene foils. Spacers were applied to produce a 0.5 mm thick membrane. After a 2 hour setting time the filter paper reinforced gelatin membrane was removed from the form and it was placed into distilled water overnight before the measurements.

#### **Preparation of the pig bladder membrane**

For the experiments, membrane disks with 10 cm diameters were cut from commercially available pig bladders and they were kept in distilled water for one day at  $+4 \text{ }^\circ\text{C}$  to stabilize their water content. The pig bladder membranes are slightly asymmetric: the surface of one side is smoother than the other. To obtain reproducible results, the membrane was always fixed in the apparatus with its smoother side facing downwards.

## Methods for wound healing

### Ethics statement

Ethical approval for the protocol and permission of the whole program (KLO2-UCD-HU\_2010) was issued by the Hungarian National Health and Medical Officer Service (ANTSZ) following the suggestion of the Scientific Committee named ETT TUKEB [19] and written informed consent was obtained from all patients.

### Treatment of chronic wounds with an aqueous ClO<sub>2</sub> solution

The solution applied contained 300 ppm high purity ClO<sub>2</sub> dissolved in distilled water (Solumium Oral<sup>®</sup> [14]). The solution was kept in a brown glass bottle which was tightly closed with a cap when not in use. Just before the treatment the cap was replaced with a spray head. For the first step of the treatment the wound was sprayed gently with the solution. (The contact with the wound does not cause discomfort as the solution does not sting.) Next one layer of non-adherent petrolatum gauze was placed on the wound together with three layers of ordinary gauze. These layers were sprayed again with the ClO<sub>2</sub> solution until they became completely wet. The bandage was finished with another three layers of dry gauze, partly to slow down the evaporation of the active ingredient and partly to decrease the patients' uncomfortable feelings due to a wet and cold bandage. The bandage was changed every 24 hours. When removing the bandage, a gentle spraying with the solution helped to detach the old gauze.

## Results

Our results cover the following themes: First, we present and evaluate membrane transport experiments aiming to determine

- i) the diffusion coefficient of ClO<sub>2</sub>  $D$  in a reactive protein medium, and
- ii) the concentration of reactive groups  $s_0$  in that medium.

To evaluate the membrane transport experiments we applied a reaction-diffusion model for the transport of ClO<sub>2</sub> in a medium containing reactive proteins. The details of that theory and the mathematical derivation of formulas applied in this section are given in the Supplemental part. Then, based on the experimentally determined  $D$  and  $s_0$  we calculate  $T_{KILL}$ , the time needed to kill bacteria by ClO<sub>2</sub>, and  $p$ , the penetration depth of ClO<sub>2</sub> into human tissue during a wound healing treatment. Finally, to illustrate that our theory can be applied in practice, we present preliminary results of some wound healing experiments.

ClO<sub>2</sub> permeation was measured via gelatin and pig bladder membranes. The apparatus is shown in Fig. 1 of the Methods section.

### Permeation of ClO<sub>2</sub> through an artificial gelatin membrane

Gelatin was our first choice for a model material because we wanted to study the ClO<sub>2</sub> transport in a protein medium with a known amino acid composition. Pork skin gelatin (Fluka 48719) contains only two amino acids that can react with ClO<sub>2</sub>: methionine (0.88 %) and tyrosine (0.6 %) [20].

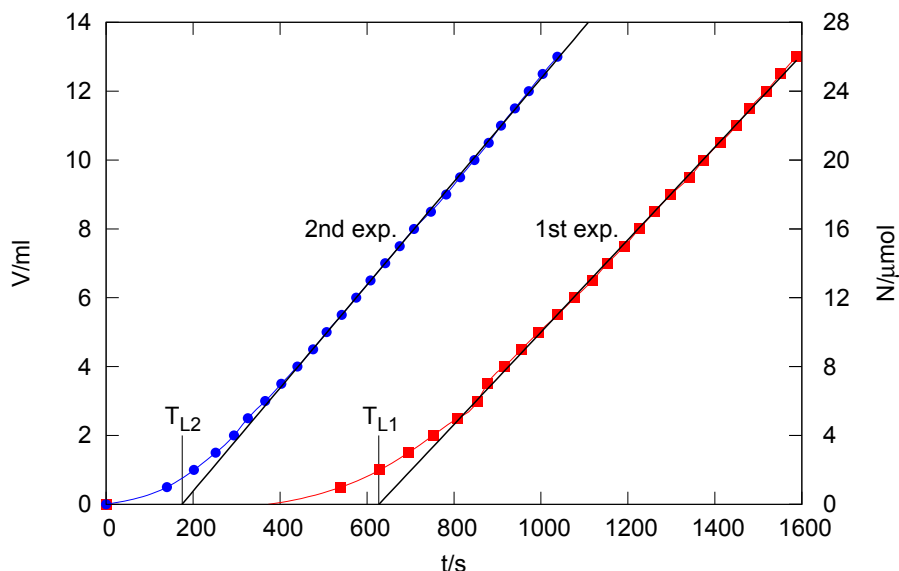

**Figure 2.** Permeation of  $\text{ClO}_2$  through a gelatin membrane as a function of time  $t$ . Each point in the diagram represents a „black burst” (see Methods).  $V$  is the cumulative volume of the 0.01 M  $\text{Na}_2\text{S}_2\text{O}_3$  titrant added before the burst and  $N$  is the amount of  $\text{ClO}_2$  permeated until time  $t$ .  $T_{L1} = 627$  s and  $T_{L2} = 175$  s are time lags of the first and the second experiments, respectively. The concentration of  $\text{ClO}_2$  source in the magnetically stirred aqueous solution was 1360 ppm (mg/kg) or 20.1 mM.

Fig. 2 shows the results of two consecutive experiments performed with the same gelatin membrane (see the two curves denoted as 1st exp. and 2nd exp.). After the first experiment, the membrane was removed from the apparatus and was kept in distilled water for 1 hour before the second experiment.

#### Calculating the $\text{ClO}_2$ diffusion coefficient $D$ and the effective concentration of $\text{ClO}_2$ consuming substrates $s_0$ in gelatin

Fig. 2. shows  $N$ , the cumulated amount of  $\text{ClO}_2$  permeated through the membrane as a function of time. It is a common feature of both curves shown in Fig. 2 that two characteristically different dynamical regimens can be observed. In the first regimen, the amount of the permeated  $\text{ClO}_2$  is very small, then, after a rapid transition period the cumulated amount of  $\text{ClO}_2$  increases linearly with time. Real dynamics can be approximated with the following simplified model: zero permeation is assumed at the beginning during a waiting period but right after that a constant diffusion current appears, thus, the permeated amount increases linearly with time. To characterize such a dynamic behaviour the concept of „time lag” can be introduced: it is the time where the asymptote of the linear regimen crosses the time axis [21].

Regarding the asymptotes of the corresponding curves, the time lag in the first and in the second experiment is  $T_{L1} = 627$  s and  $T_{L2} = 175$  s, respectively. A logical explanation for this difference is that some  $\text{ClO}_2$  is consumed inside the gelatin in the rapid reaction with methionine and tyrosine. So  $\text{ClO}_2$  can break through only after it eliminates all these highly reactive amino acid residues. In the case of the second experiment, the breakthrough occurs earlier as most of these residues already reacted with  $\text{ClO}_2$  during the first experiment.

If we assume that in the second experiment the reaction plays a minor role only, then in that case, the time lag is entirely due to diffusion. Roughly speaking the diffusional time lag is the time

necessary to establish a steady state concentration profile inside the membrane that is to “fill up” the membrane with ClO<sub>2</sub>. Based on dimensional analysis considerations (the dimension of the diffusion coefficient is (length)<sup>2</sup>/(time) ) we can expect that the time lag should be proportional with the square of the thickness and inversely proportional with the diffusional coefficient. Really, the exact result [21] is that the diffusional time lag  $T_{DM}$  for a membrane of thickness  $d$  can be calculated as:

$$T_{DM} = \frac{1}{6} \cdot \frac{d^2}{D} \quad (1)$$

Thus, with the assumption  $T_{L2} = T_{DM} = 175$  s,  $D$ , the diffusion coefficient of ClO<sub>2</sub> in the gelatin membrane can be calculated knowing that  $d = 0.5$  mm. The result:  $D = 2.4 \times 10^{-6}$  cm<sup>2</sup>s<sup>-1</sup>.

$D$  can be determined in another way as well, from the steady state regimen. The steady state ClO<sub>2</sub> current is the slope of the curve in the linear regimen. For the 2nd experiment  $J_2 = 30$  nmol/s.

Then Fick's law of diffusion

$$J = A \cdot D \cdot \frac{\Delta c}{d} \quad (2)$$

can be applied to calculate  $D$ . Here  $A = 28.3$  cm<sup>2</sup> is the active cross-section of the membrane and  $\Delta c$  is the concentration difference between the two sides of the membrane. Regarding our boundary conditions  $\Delta c = c_0 = 20.1 \times 10^{-3}$  M. This way  $D = 2.6 \times 10^{-6}$  cm<sup>2</sup>s<sup>-1</sup> is obtained.

The two  $D$  values, the one calculated from the time lag and the other calculated from the steady state, agree reasonably well indicating that indeed the 175 s time lag is caused mostly by diffusion and any delay due to chemical reactions is negligible in the second experiment.

On the other hand, in the first experiment, the time lag  $T_{RM}$  is caused mostly by the reaction between ClO<sub>2</sub> and the reactive amino acid residues (in short “substrates”) in the membrane. It is important to realize that  $T_{RM}$  is not due to a slowness of the reaction kinetics (as the rate constants of the relevant ClO<sub>2</sub> – amino acid reactions are relatively high [22], [23], [24]), but it is due to the actual ClO<sub>2</sub> consumption by the reactions within the membrane delaying the breakthrough. If we assume that the rate of the chemical reaction is limited by the diffusional transport of ClO<sub>2</sub> across a zone already without reactive amino acids toward a zone of unreacted ones, then a sharp reaction front will develop on the boundary of the two zones (see Supplemental Figure S1). The front starting from one side of the membrane and driven by diffusion, propagates slowly through the membrane and  $T_{RM}$  is the time when it arrives to the other side of the membrane. According to a detailed derivation in the Supplementary part,  $T_{RM}$  can be given by the so-called parabolic rate law (see Supplemental equation (S12)):

$$T_{RM} = \frac{1}{2} \cdot \frac{s_0}{c_0} \cdot \frac{d^2}{D} \quad (3)$$

where  $s_0$  is the initial effective substrate concentration, i.e. the ClO<sub>2</sub> consuming capacity of the membrane in unit volume, and  $c_0$  is ClO<sub>2</sub> concentration at the boundary of the membrane.

Substituting the more reliable diffusion coefficient measured in the steady-state of the second experiment  $D = 2.6 \times 10^{-6}$  cm<sup>2</sup>s<sup>-1</sup> and applying the assumption that  $T_{RM} = T_{LI} = 627$  s, the effective substrate concentration of the gelatin membrane  $s_0$  can be calculated. The result:  $s_0 = 26.2$  mM.

### **Permeation of ClO<sub>2</sub> through a pig bladder membrane**

In this experiment, we studied the ClO<sub>2</sub> permeability of a pig bladder membrane which is a relatively thin (in our case it was 0.5 mm thick) but sturdy animal tissue. The same apparatus was



applied as in the case of the gelatin membrane and the experimental points were depicted in Fig. 3 also with the same method.

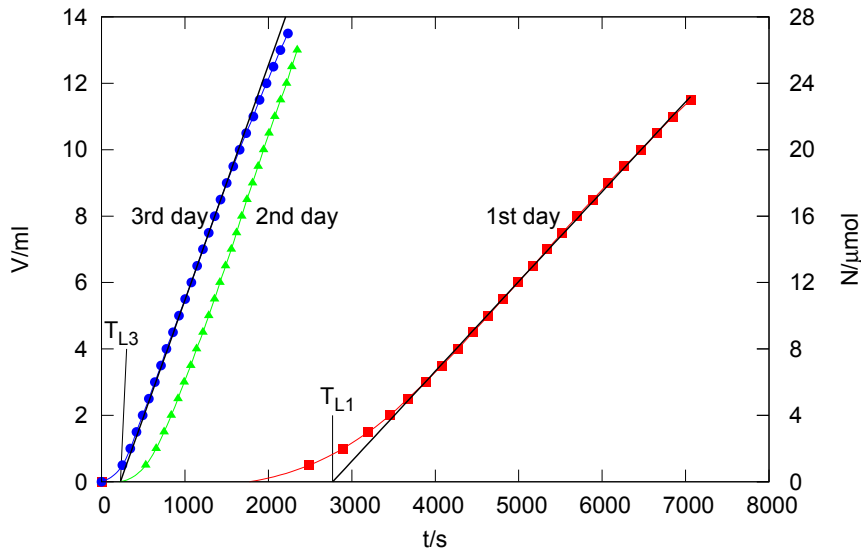

**Figure 3.** Permeation of  $\text{ClO}_2$  through a pig bladder membrane as a function of time  $t$ .

$V$  and  $N$  have the same meaning like in Fig. 2.  $T_{L1} = 2770$  s,  $T_{L2} = 586$  s and  $T_{L3} = 226$  s are time lags of the experiments performed on the 1st, 2nd, and 3rd day, respectively. The concentration of the  $\text{ClO}_2$  source was 946 ppm (14.0 mM) in these experiments.

All the three measurements (indicated as 1st day, 2nd day and 3rd day) were performed with the same pig bladder membrane but on three successive days. The membrane was kept in distilled water at  $+4$  °C overnight between the experiments which were always started with fresh solutions.

To check the reproducibility of our measurements, we repeated the measurements with another pig bladder membrane (not shown in the Figure). While the new membrane was from a different pig bladder and its blood vessel pattern was also different, the relative deviation between the results of the two series of experiments was surprisingly small: only about 10 %. (The blood vessel structure of the membrane becomes visible as a dark network before a „black burst” because the permeability of the membrane is somewhat higher through those vessels.)

Another interesting observation was that the pig bladder membrane maintained its integrity and its mechanical strength even after the third experiment. This is because  $\text{ClO}_2$  reacts selectively with certain amino acid residues of the proteins but does not destroy the peptide bonds thus the primary protein structure can survive.

### Calculating the $\text{ClO}_2$ diffusion coefficient and the effective concentration of $\text{ClO}_2$ consuming substrates in pig bladder

Evaluation of the results was made in a similar way as in the case of the gelatin membrane. It was assumed that the time lag measured in the third experiment  $T_{L3} = 226$  s is a purely diffusional time lag that is  $T_{L3} \approx T_{DM}$ . The diffusion coefficient of  $\text{ClO}_2$  in a pig bladder membrane calculated from the above assumption is  $D = 1.84 \times 10^{-6} \text{ cm}^2 \text{ s}^{-1}$ . That value is in good agreement with the  $D = 1.80 \times 10^{-6} \text{ cm}^2 \text{ s}^{-1}$  value calculated from the steady state current  $J_3 = 14.1 \text{ nmol/s}$  of the 3rd experiment.

As we can see, the diffusion coefficient of ClO<sub>2</sub> in a pig bladder tissue is only 30 % smaller than in the unstructured gelatin. This supports our assumption that the cellular structure of the pig bladder tissue does not matter too much from the point of the diffusional transport of ClO<sub>2</sub> as it can penetrate through the external and internal lipid membranes of the individual cells of the tissue.

However, there is a more significant deviation between the pig bladder and the gelatin regarding  $s_0$ , the effective substrate concentration. Assuming that the time lag in the first experiment  $T_{LI} = 2770$  s is due to the chemical reaction,  $T_{LI} \approx T_{RM}$ , then from (3) we get  $s_0 = 56$  mM, indicating that the concentration of the reactive components in the pig bladder tissue is about two times higher than that is in the gelatin. This is a reasonable result as the animal tissue is denser, and it contains not only methionine and tyrosine like gelatin, but also cysteine and tryptophan residues. We would like to add that in a series of measurements performed with the same membrane the steady state ClO<sub>2</sub> current in the first experiment is always smaller than in the subsequent ones, although the ClO<sub>2</sub> source is not changed. This effect is more pronounced in the case of an animal membrane (compare the slope of the 1st day experiment with that of the other days). The phenomenon can be understood if we assume that some components, which are able to react with ClO<sub>2</sub> but only slowly, can remain in the pig bladder even after the first ClO<sub>2</sub> breakthrough. As it is shown in the Supplemental equation (S40), the slow ClO<sub>2</sub> consumption of these components can explain a smaller quasi-steady state current. The fact that these components disappear from the membrane after keeping it in water overnight suggests that they are reaction products which can be leached out from the membrane or are unstable intermediates which decompose.

### Estimating the killing time for bacteria with cylindrical and spherical geometries

We assume that a bacterium is killed when its whole volume is flooded by ClO<sub>2</sub>. To calculate the killing time, if we know the shape and the size of the bacterium, we would need two more parameters, the diffusion coefficient of ClO<sub>2</sub>  $D$  and the effective concentration of ClO<sub>2</sub> consuming substrates  $s_0$  in the bacterial medium. In the absence of bacterial data it will be assumed that the parameters  $D$  and  $s_0$  in the single cell of a bacterium are close to that what we have measured above in the animal cell aggregates of the pig bladder. A further simplifying assumption is that only spherical and cylindrical bacteria are considered. Numerical results are calculated for a diameter of 1  $\mu\text{m}$ , which is a characteristic length-scale for bacteria.

Mathematical formulas for the killing time and the penetration depth are derived in the Supplemental part. In this section only the results of those derivations will be given together with some qualitative explanations on their meaning.

It will be assumed that the rate of the “ClO<sub>2</sub> – bacterium reaction” is also limited by the diffusion of ClO<sub>2</sub> to the fast reacting amino acid residues fixed in protein molecules like in the case of the much larger membranes and this way a sharp reaction front propagates from the cell wall toward the centre of the bacterium.

Intuitively, the killing time  $T_{KILL}$  should be analogous to the time lag  $T_{RM}$  in a membrane caused by a chemical reaction, because these are the times needed to flood the whole volume. We can expect, however, that the geometric factor should be different depending on the shape of the bacterium. For a cylindrical bacterium with a diameter of  $d$  the killing time is

$$T_{KILL,C} = \frac{1}{16} \cdot \frac{s_0}{c_0} \cdot \frac{d^2}{D} \quad (4)$$

see supplemental equation (S18),

and for a spherical bacterium also with a diameter of  $d$  it is

$$T_{KILL,S} = \frac{1}{24} \cdot \frac{s_0}{c_0} \cdot \frac{d^2}{D} \quad (5)$$

according to supplemental equation (S24). We can see that (4) and (5) are analogous to (3) but the geometric factors for a cylinder and for a sphere are much smaller than for the planar membrane indicating that in these geometries the surface from where diffusion current is starting is relatively larger compared to the volume that has to be flooded.

Substituting the pig bladder parameters  $D = 1.8 \times 10^{-6} \text{ cm}^2 \text{ s}^{-1}$  and  $s_0 = 56 \text{ mM}$  into formulas (4) and (5) together with the  $\text{ClO}_2$  concentration applied in the wound healing experiments (see later)  $c_0 = 4.45 \text{ mM}$  (Solumium Oral<sup>®</sup>, 300 ppm) and using  $d = 1 \text{ }\mu\text{m}$  we obtain that the killing time for a cylindrical bacterium with a diameter of  $1 \text{ }\mu\text{m}$  is

$$T_{KILL,C} = 4.4 \text{ ms} ,$$

while the killing time for a spherical bacterium with a diameter of  $1 \text{ }\mu\text{m}$  is

$$T_{KILL,S} = 2.9 \text{ ms} .$$

As we can see, the killing time for a bacterium is only a few ms due to its small size. Even if  $s_0$ , the effective substrate concentration of a bacterium would be an order of magnitude higher than we assumed, the killing time would be still less than 0.1 s. Other approximations applied in our calculations can only overestimate the real killing time. For example, the diffusion coefficient of  $\text{ClO}_2$  in the pig bladder was measured at  $24 \pm 2 \text{ }^\circ\text{C}$ . If  $\text{ClO}_2$  is used to disinfect a living human tissue, the temperature is higher, which means a larger diffusion coefficient and an even shorter killing time. Another approximation is the concept of fixed substrates. Inside a bacterium mobile substrates like glutathione [25], free amino acids and various antioxidants also occur. These small molecules can diffuse by and large freely within the bacterium. Nevertheless  $T_{KILL}$  would still work as a good upper estimate because the mobility of the substrate can only shorten the time needed for  $\text{ClO}_2$  to reach these substrates and react with them. Furthermore, when the killing time  $T_{KILL}$  is regarded as the time when the sharp front reaches the center of the sphere or the symmetry axis of the cylindrical bacterium, it will surely be overestimated, as it is not necessary to oxidize all the available substrate content of a bacterium to kill it. For example, it is enough to oxidize less than 40 % of the methionine content of *E. coli* to achieve a 100 % kill [26].

### **Contact time and penetration depth of $\text{ClO}_2$ into human skin or wound**

When an organism is not submerged in the aqueous  $\text{ClO}_2$  solution but the solution is applied on its surface only, as in the case of disinfecting wounds, the volatility of  $\text{ClO}_2$  also has to be taken into account. The effective contact time is much shorter using a  $\text{ClO}_2$  solution than with less or non-volatile disinfectants. According to our measurements, when a wound is covered with 3 wet and 3 dry layers of gauze **more than 80 % of  $\text{ClO}_2$  evaporates from the bandage within one minute due to the high volatility of  $\text{ClO}_2$  and to the high specific surface of the gauze.** Thus, to give an upper limit for the penetration depth into the human tissue, we will assume that the initial  $\text{ClO}_2$  concentration ( $c_0 = 4.45 \text{ mM}$ , Solumium Oral<sup>®</sup>) is maintained for 60 s, that is  $T_{CON} = 60 \text{ s}$ , where  $T_{CON}$  denotes the contact time. As a zero-th estimate, we assume again that the human tissue has the same  $D$  and  $s_0$  values like that of the pig bladder tissue.

Applying the parabolic rate law (see Supplemental equation (S13) where  $t = T_{CON}$ ) the penetration depth  $p$  can be estimated:

$$p = \sqrt{\frac{2c_0 D \cdot T_{CON}}{s_0}} \quad (6)$$

$p(T_{CON} = 60 \text{ s}) = 41.5 \text{ } \mu\text{m}$ . We remark that (6) can be derived from (3) directly if we realize that for the present problem  $d = p$  and  $T_{RM} = T_{CON}$ .

Nevertheless, the actual penetration depth into a living tissue - either its surface is a wound or an intact human skin – should be even much smaller than the above estimate. This is due to the capillary circulation which is present in living tissue but is absent from dead tissue like the pig bladder membrane used for the measurements. The serum in the blood vessels and also the extracellular fluid contain many components capable of reacting rapidly with  $\text{ClO}_2$ . The fluid transport of these reactive components in the blood capillaries of the dermis [27] can maintain a finite reactant concentration in that region. Then the diffusive transport of these reactants outward from the dermis into the epidermis [27] can halt an inward propagating reaction front establishing a steady state.

Moreover, in the case of intact human skin,  $\text{ClO}_2$  should permeate through the stratum corneum [28] first, which is the 10–40  $\mu\text{m}$  thick outermost layer of epidermis consisting of several layers of dead cells. This keratinous layer forms a barrier to protect the underlying tissue from infection, dehydration and chemicals. The diffusion coefficient of  $\text{ClO}_2$  in that layer should be much lower compared to the underlying tissue.

As we can see, **the penetration depth into human skin is only few tens of a micrometer even if we neglect circulation. Such shallow penetration cannot really harm human tissues.** On the other hand, this short contact time is still several orders of magnitude larger than the killing time,  $T_{CON} \gg T_{KILL}$ , which is the necessary criterion of a successful disinfection.

### **Therapeutic window**

The above formulas and calculations indicate that disinfection of living tissues with aqueous  $\text{ClO}_2$  solutions has a very wide therapeutic window: **while surprisingly low concentrations and short contact times are able to kill bacteria, much higher concentrations and residence times are still safe to use.**

**There is one notable exception: inhaling high concentration  $\text{ClO}_2$  gases for an extended time can be dangerous for human health because the alveolar membrane is extremely thin (a mere 1-2 microns and in some places even below 1 micron). The effect of  $\text{ClO}_2$  in these membranes is somewhat counterbalanced, however, by the intense blood circulation there.**

### **Treatment of non-healing wounds with a dilute $\text{ClO}_2$ solution**

A medical research program was approved in 2011 in two hospitals in Hungary to test how safe and effective  $\text{ClO}_2$  is as a local antiseptic. The aim of this program among others is to treat otherwise non-healing wounds with a dilute high purity chlorine dioxide solution (300 ppm  $\text{ClO}_2$ , Solumium Oral<sup>®</sup>). Until now more than 50 patients with chronic wounds were treated successfully. The following three Figures are preliminary results taken from a longer and more detailed report, the preparation of which is in progress. A bacterial spectrum belonging to each Figure is given in Supplementary Table S3.



**Figure 4.** Patient I.

65 years old female patient who got deep vein thrombosis some years ago. She was treated with recurrent ulcer several times, and in this state she was admitted to the hospital.

- a) Nov 8 2011: The state before Solumium solution treatment was started.
- b) Nov 19 2011: Status during treatment, the clearance and the granulation of the wound is definitely visible. The necrotic biofilm was gone. From this point the wound dressings were completed also with flexible swaddling.
- c) Nov 25 2011: Beside the wound granulation also the epithelialisation in the edge region has started.
- d) Dec 7 2011: Epithelialisation progressed and the ulcer was healed almost completely.



**Figure 5. Patient II.**

60 year old woman having severe diabetes for years, treated with insulin. She was admitted to hospital and operated on festering and necrosis of the toes that developed on the basis of the foot neuropathy and angiopathy.

- a) Jan. 16 2012: The image shows the status after the removal of the toes and the resection of dead skin and subcutaneous tissue. At this point Solumium solution treatment was started
- b) Feb. 28 2012: After granulation of the wound base it was covered with a half-thick lobe of skin and Solumium solution treatment was continued.
- c) Sept. 17 2012: The healed state. (The actual wound healing had been completed much earlier. The picture was taken later when the patient returned to the hospital to check her state.)



**Figure 6. Patient III.**

52 years old man with tablet-treated diabetes. He suffered a motor accident in April 2012. An extensive hematoma was formed under the leg skin that suppurated and also the plate of the connective tissue covering the muscles necrosed.

- a) May 15 2012: The picture shows the status after surgical exploration in which the necrosed tissue was excised. The wounds were kept open and Solumium treatment was started.
- b) May 17 2012: Condition during treatment, the wound base started granulating

c) June 16 2012: After the clearance of the lower wound it could be closed with direct sutures. The upper wound which also cleared up and granulated was covered with a half-thick lobe of skin taken from the thigh. Solumium treatment was continued

d) August 27 2012: The healed state. (The actual wound healing had been completed much earlier. The picture was taken later when the patient returned to the hospital to check his state.)

The preliminary results prove that aqueous  $\text{ClO}_2$  solutions can be applied to heal chronic wounds. To compare the performance of  $\text{ClO}_2$  with other antiseptics requires further study, which is planned. It is encouraging, however, that all treated patients were healed and  $\text{ClO}_2$  caused no inflammatory response in any patients.

## Discussion

In this section first we discuss whether  $\text{ClO}_2$  should be regarded as an “exotic” antiseptic only or it has the promise to become a commonly used antiseptic to treat local infections. To this end safety and effectiveness requirements for a local antiseptic are collected to check how  $\text{ClO}_2$  can meet these requirements compared to other antiseptics.

Next a biochemical action mechanism, explaining the antiseptic effect of  $\text{ClO}_2$  is discussed, which is partly analogous to that of hypochlorous and hypoiodous acids. These “natural” antiseptics also react, among others, with sulfhydryl groups like  $\text{ClO}_2$  but their reaction products can be different. The importance of that difference and the protective role of SH groups and of the circulatory system, existing in a multicellular organism only, is also discussed.

### Safety and effectiveness requirements for a local antiseptic

A local antiseptic should meet the following requirements to be considered as safe:

- i) it should act only locally to avoid systemic poisoning, and
- ii) it should not prevent or delay the process of healing, i.e. it should not be cytotoxic.

and as effective:

- iii) it should be effectual in relatively low concentrations, and even in biofilms (biofilms are medically important, accounting for over 80 percent of microbial infections in the body [29]) as well, and
- iv) microbes should not be able to develop resistance against it (a problem related to the biochemical mechanism of action).

As it was shown in the Results section  $\text{ClO}_2$  as a size selective antiseptic, meets requirements i) and ii). Thus only criteria iii) and iv) are discussed here.

### Comparing the biocidal activity of $\text{ClO}_2$ to that of other antiseptics (criterion iii)

In free aqueous solutions, the strongest chemical disinfectant is ozone. In biofilms, however, the performance of ozone is rather poor. In addition, ozone is toxic and decomposes in aqueous solutions rapidly. (Its half life is only 15 min at 25 °C at pH 7.) All of these disadvantageous properties of ozone prevent its use as an antiseptic in most applications.

The second strongest disinfectant after ozone is chlorine dioxide. Tanner [30] made a comparative testing of eleven disinfectants on three test organisms (including two bacteria: *Staphylococcus aureus* and *Pseudomonas aeruginosa* and one yeast: *Saccharomyces cerevisiae*).

He found that the disinfectant containing  $\text{ClO}_2$  had the highest biocidal activity on a mg/l basis against the test organisms. Beside antibacterial and antifungal properties,  $\text{ClO}_2$  also shows strong antiviral activity, about ten times higher than that of sodium hypochlorite [31]. And it inactivates practically all microbes including algae and animal planktons [32] and protozoans [33]. Moreover  $\text{ClO}_2$  can remove biofilms swiftly [12] because it is highly soluble in water and unlike ozone it does not react with the extracellular polysaccharides of the biofilm. This way  $\text{ClO}_2$  can penetrate into biofilms rapidly to reach and kill the microbes living within the film.

#### **Impossibility of bacterial resistance against $\text{ClO}_2$ (criterion iv)**

$\text{ClO}_2$  is a strong, but a rather selective oxidizer. Unlike other oxidants it does not react (or reacts extremely slowly) with most organic compounds of a living tissue.  $\text{ClO}_2$  reacts rather fast, however, with cysteine [22] and methionine [34] (two sulphur containing amino acids), with tyrosine [23] and tryptophan [24] (two aromatic amino acids) and with two inorganic ions:  $\text{Fe}^{2+}$  and  $\text{Mn}^{2+}$ . It is generally assumed that the antimicrobial effect of  $\text{ClO}_2$  is due mostly to its reactions with the previously mentioned four amino acids and their residues in proteins and peptides. In the peptide group it is important to mention glutathione – a small tripeptide containing cysteine - which is a major antioxidant in cells, with an intracellular concentration of 0.1-10 mM [35].

Margerum's group [22], [23], [24] reported the following second order rate constants at pH 7 and 25 °C: cysteine  $1 \times 10^7 \text{ M}^{-1} \text{ s}^{-1} \gg$  tyrosine  $1.8 \times 10^5 \text{ M}^{-1} \text{ s}^{-1} >$  tryptophan  $3.4 \times 10^4 \text{ M}^{-1} \text{ s}^{-1}$ . As can be seen, cysteine is the far most reactive amino acid because of its thiol group. As the above mentioned four amino acids and especially cysteine and biological thiols play a crucial role in all living systems, including microbes, it is impossible for any microbe to develop a resistance against chlorine dioxide.

As an important analogy we can mention that bacteria have never been able to become resistant against hypochlorous acid (HOCl) either, which is an important natural antiseptic used by neutrophils for millions of years. Neutrophils, a type of white blood cells, are phagocytes which kill the engulfed microbes by applying various hydrolytic enzymes and hypohalogeneous acids, chiefly HOCl [36], [37]. On that basis Robson and co-workers applied HOCl as a kind of „natural” wound care agent [38], [39]. Thus, it is reasonable to compare the action mechanisms and other properties of  $\text{ClO}_2$  and HOCl as antiseptic agents.

#### **Comparison of $\text{ClO}_2$ and HOCl as possible antiseptic agents**

HOCl, like  $\text{ClO}_2$ , reacts rapidly with the sulphur containing amino acid residues of methionine and cysteine, the second order rate constant (at pH 7.4 and 22 °C) being  $3.8 \times 10^7 \text{ M}^{-1} \text{ s}^{-1}$  and  $3.0 \times 10^7 \text{ M}^{-1} \text{ s}^{-1}$ , respectively, and also reacts with tryptophan ( $1.1 \times 10^4 \text{ M}^{-1} \text{ s}^{-1}$ ) and tyrosine ( $4.4 \times 10^4 \text{ M}^{-1} \text{ s}^{-1}$ ) [40]. However, unlike  $\text{ClO}_2$ , HOCl reacts rapidly with many other amino acid residues and even with peptide bonds [40], and many other compounds such as carbohydrates, lipids, nucleobases, and amines [41].

As we can see the important similarity is the fast reaction of both HOCl and  $\text{ClO}_2$  with the SH group of cysteine. This is important because it is assumed that abolition of ATP synthesis and killing bacteria by HOCl is due to its reaction with sulfhydryl groups [18]. It is a logical assumption that  $\text{ClO}_2$  can also stop the ATP synthesis as it reacts with the very same SH groups like HOCl.

At the same time, however, there are important dissimilarities between HOCl and  $\text{ClO}_2$ :

i) HOCl is much less specific and reacts rapidly with numerous other substrates. Thus killing bacteria with HOCl requires more reagent than with  $\text{ClO}_2$ .



ii) While  $\text{ClO}_2$  evaporates rapidly from its aqueous solution and can reach and kill bacteria even through a gas phase, e.g. through an air bubble blocking a dental root canal [42], evaporation of HOCl is not significant. Thus HOCl stays at the disinfected area for a long time even after killing all bacteria which can cause inflammation there [43].

iii) HOCl is a more drastic reagent and causes irreversible damage. For example  $\text{ClO}_2$  oxidizes glutathione (GSH) mainly to glutathione disulfide (GSSG) [22] which can be reduced back to GSH easily in a natural way in the body. On the other hand, HOCl can attack disulfide bonds and oxidizes GSH mostly to glutathione sulfonamide (GSA) [44] causing an irreversible loss of the cellular GSH.

### **Sulfhydryl groups and circulation can protect multicellular organisms from $\text{ClO}_2$ inflicted irreversible damage**

As it was mentioned, the  $\text{ClO}_2$ –SH group reaction has the highest rate constant among the  $\text{ClO}_2$ –amino acid reactions. (Cysteine or GSH [22] reacts about 50 times faster than the runner up tyrosine.)

Consequently, as long as some SH groups are present (mostly in the form of GSH), these groups react with  $\text{ClO}_2$  rapidly protecting other amino acid residues from oxidative damage.

Moreover the oxidation of SH groups to disulfide bonds can be reversed. An interesting example was presented by Müller and Kramer [45], [46]. They found that the cytotoxic effect of povidone-iodine after a 30 min contact with murine fibroblast was only temporal: after a 24 hour culture without the antiseptic an unexpected revitalization of the fibroblasts was observed [45].

According to Winterbourn and co-workers [47], HOI (the reactive hydrolysis product of iodine) also oxidises GSH to GSSG but not to GSA. That parallelism between the reversible HOI-GSH and the  $\text{ClO}_2$ –GSH reactions raises the question whether an analogous revitalization might be also possible in the case of  $\text{ClO}_2$ . This question is all the more justified since in some animal experiments [16] rats were drinking water containing 200 ppm  $\text{ClO}_2$  for 90 days but without developing any gastrointestinal problems. In those experiments all  $\text{ClO}_2$  must have reacted with the animal tissues as it cannot evaporate from the stomach of the rats. To interpret that result it is reasonable to assume that SH groups transported by the circulation system of the rodent protected the epithelial cells in its gastrointestinal tract from an irreversible oxidation by  $\text{ClO}_2$ .

Above a certain limit, however, when a too high percentage of the protective SH groups is already oxidized,  $\text{ClO}_2$  would inflict irreversible changes to the higher order protein structures by oxidizing the tyrosine and tryptophan residues [48]. That would certainly happen with the bacteria on the surface of an infected tissue as their GSH supply [26] can be rapidly exhausted by  $\text{ClO}_2$ . Mammalian cells below the surface, however, might survive being supported by the circulation which transports protective sulfhydryl and other reductive compounds to the cells, continuously repairing or even revitalizing them.

Thus beside their size there is another important difference between single cell and more complex multicellular organisms: it is the circulation which can help the cells of a multicellular organism to survive while that type of help is not available for a bacterium.

## **Conclusion**

Chlorine dioxide is a size selective antimicrobial agent which can kill micron sized organisms rapidly but cannot make real harm to much larger organisms like animals or humans as it is not able to penetrate deeply into their living tissues. Moreover the circulation of multicellular organisms can provide an additional protection to these organisms against  $\text{ClO}_2$ .

The predicted wide therapeutic ClO<sub>2</sub> concentration window in antiseptic applications was tested in wound healing experiments with promising results. These results are preliminary ones, however, and a detailed experimental study to compare high purity aqueous ClO<sub>2</sub> solutions with other antiseptics is needed. It is an aim of the present work to initiate such studies hoping that ClO<sub>2</sub> could be applied to treat various local infections, especially where bacterial resistance is a problem.

## Acknowledgments

The authors thank Ms. Marianna Megyesi for performing the physico-chemical experiments and Dr. György Berencsi, Dr. Mihály Kádár, Dr. Márta Milassin, Prof. Ferenc Rozgonyi and Dr. Gusztáv Várnai for helpful discussions. We also thank Ms. Mary-Beth Sinamon for proofreading our MS as a native English speaker.

## Author Contributions

Z. N. conceived and designed the physico-chemical experiments and wrote the manuscript, M. W. and K. K. contributed to the reaction-diffusion model and mathematical derivations and performed data analysis, Z. B. treated the chronic wounds shown in the paper and made the photos to document the process of healings, I. K., L. R. and J. Sz. organized the medical research, performed preliminary tests and wrote the protocols for the wound healing experiments. All authors contributed to discussions and reviewed the manuscript.

## References

1. Amyes SGB (2010) Antibacterial Chemotherapy. Theory, Problems and Practice. Oxford: Oxford Univ. Press.
2. Spellberg B (2009) Rising Plague. The Global Threat from Deadly Bacteria and Our Dwindling Arsenal to Fight Them. Amherst, NY: Prometheus Books.
3. Evans BA, Hamouda A, Amyes, SGB (2013) The rise of carbapenem-resistant *Acinetobacter baumannii*. *Curr Pharm Des* 19(2): 223-238.
4. Luo G, Lin L, Ibrahim AS, Baquir B, Pantapalangkoor P, et al. (2012) Active and Passive Immunization Protects against Lethal, Extreme Drug Resistant-*Acinetobacter baumannii* Infection. *PLOS ONE* 7(1): e29446. doi:10.1371/journal.pone.0029446
5. McDonnell G, Russell AD (1999) Antiseptics and disinfectants: activity, action, and resistance. *Clin Microbiol Rev* 12: 147–179.
6. Koburger T, Hübner NO, Braun M, Siebert J, Kramer A (2010) Standardized comparison of antiseptic efficacy of triclosan, PVP-iodine, octenidine dihydrochloride, polyhexanide and chlorhexidine digluconate. *J Antimicrob Chemother* 65: 1712–1719.
7. Lansdown ABG (2010) Silver in Healthcare: Its Antimicrobial Efficacy and Safety in Use. *Issues in Toxicology*. Cambridge: RSC Publications.
8. Das S (2011) Application of ozone therapy in dentistry. Review. *Ind J Dent Adv* 3: 538–542.
9. Mehra P, Clancy C, Wu J (2000) Formation of facial hematoma during endodontic therapy. *J Am Dent Assoc* 131: 67–71.
10. Cadenas E (1989) Biochemistry of oxygen toxicity. *Annu Rev Biochem* 58: 79–110.

11. Harris AG, Hinds FE, Beckhouse AG, Kolesnikow T, Hazell SL (2002) Resistance to hydrogen peroxide in *Helicobacter pylori*: role of catalase. *Microbiology* 148: 3813–3825.
12. Simpson GD, Miller RF, Laxton GD, Clements WR (1993) A focus on chlorine dioxide: the "ideal" biocide. *Corrosion* 93, New Orleans, LA, March 8-12. Paper No. 472.  
<http://www.clo2.gr/en/pdf/secure/chlorinedioxideidealbiocide.pdf> Accessed 15 April 2013.
13. Noszticzius Z, Balogh S, Gyökérné Wittmann M, Kály-Kullai K, Megyesi M, Volford A (2006) Permeation method and apparatus for preparing fluids containing high purity chlorine dioxide. <http://patentscope.wipo.int/search/en/WO2008035130> Accessed 15 April 2013.
14. [www.solumium.com](http://www.solumium.com) Accessed 15 April 2013.
15. Csikány Cs, Várnai G, Noszticzius Z (2009) SOLUMIUM DENTAL: a hipertiszta klórdioxid oldat és alkalmazása a fogorvosi gyakorlatban II. (SOLUMIUM DENTAL: Application of high purity chlorine dioxide solution in the dental practice II., in Hungarian) *Dental Hírek* 2009/5: 36-38.
16. Daniel FB, Condie LW, Robinson M, Stober JA, York RG, et al. (1990) Comparative 90-day subchronic toxicity studies on three drinking water disinfectants, chlorine, monochloramine and chlorine dioxide in the Sprague-Dawley rats. *J Am Water Works Assoc* 82: 61–69.
17. Lubbers JR, Chauhan SR, Bianchine JR (1982) Controlled clinical evaluations of chlorine dioxide, chlorite and chlorate in man. *Environ Health Perspect* 46: 57–62.
18. Barrette WC Jr, Hannum DM, Wheeler WD, Hurst JK (1989) General mechanism for the bacterial toxicity of hypochlorous acid: abolition of ATP production. *Biochemistry* 28: 9172–9178.
19. <http://www.ett.hu/tukeb.htm> Accessed 15 April 2013.
20. Eastoe JE (1955) The amino acid composition of mammalian collagen and gelatin. *Biochem J* 61: 589–600.
21. Crank J (1975) *Mathematics of Diffusion*. Oxford: Clarendon. 51 p.
22. Ison A, Odeh IN, Margerum DW (2006) Kinetics and mechanisms of chlorine dioxide and chlorite oxidations of cysteine and glutathione. *Inorg Chem* 45: 8768–8775.
23. Napolitano MJ, Green BJ, Nicoson JS, Margerum DW (2005) Chlorine dioxide oxidations of tyrosine, N-acetyltyrosine, and Dopa. *Chem Res Toxicol* 18: 501–508.
24. Stewart DJ, Napolitano MJ, Bakhmutova-Albert EV, Margerum DW (2008) Kinetics and mechanisms of chlorine dioxide oxidation of tryptophan. *Inorg Chem* 47: 1639–1647.
25. Chesney JA, Eaton JW, Mahoney JR (1996) Bacterial glutathione: a sacrificial defense against chlorine compounds. *J Bacteriol* 178: 2131–2135.
26. Rosen H, Klebanoff SJ, Wang Y, Brot N, Heinecke JW, Fu X (2009) Methionine oxidation contributes to bacterial killing by the myeloperoxidase system of neutrophils. *Proc Natl Acad Sci U S A* 106: 18686–18691. 18688 p. Fig. 3B.
27. <http://en.wikipedia.org/wiki/Skin> Accessed 15 April 2013.
28. [http://en.wikipedia.org/wiki/Stratum\\_corneum](http://en.wikipedia.org/wiki/Stratum_corneum) Accessed 15 April 2013.
29. [Research on microbial biofilms \(PA-03-047\)](#) NIH. Accessed 15 April 2013.
30. Tanner R (1989) Comparative testing and evaluation of hard-surface disinfectants. *J Ind Microbiol* 4: 145–154.
31. Sanekata T, Fukuda T, Miura T, Morino H, Lee C, et al. (2010) Evaluation of the antiviral activity of chlorine dioxide and sodium hypochlorite against feline calicivirus, human influenza virus, measles virus, canine distemper virus, human herpesvirus, human adenovirus, canine adenovirus and canine parvovirus. *Biocontrol Sci* 15/2: 45–49.

32. Junli H, Li W, Nenqi R, Li LX, Fun SR, Guanle Y (1997) Disinfection effect of chlorine dioxide on viruses, algae and animal planktons in water. *Water Res* 31: 455–460.
33. EPA Guidance Manual, Alternative Disinfectants and Oxidants, 4.4.3.2 Protozoa Inactivation. [http://www.epa.gov/ogwdw/mdbp/pdf/alter/chapt\\_4.pdf](http://www.epa.gov/ogwdw/mdbp/pdf/alter/chapt_4.pdf) Accessed 15 April 2013.
34. Loginova IV, Rubtsova SA, Kuchin AV (2008) Oxidation by chlorine dioxide of methionine and cysteine derivatives to sulfoxide. *Chemistry of Natural Compounds* 44: 752–754.
35. Meister A (1988) Glutathione metabolism and its selective modification. *J Biol Chem* 263: 17205–17208.
36. Nauseef WM (2007) How human neutrophils kill and degrade microbes. An integrated view. *Immunol Rev* 219: 88–102.
37. Rosen H, Klebanoff SJ, Wang Y, Brot N, Heinecke JW, Fu X (2009) Methionine oxidation contributes to bacterial killing by the myeloperoxidase system of neutrophils. *Proc Natl Acad Sci U S A* 106: 18686–18691.
38. Wang L, Bassiri M, Najafi R, Najafi K, Yang J, et al. (2007) Hypochlorous acid as a potential wound care agent, Part I. *J Burns Wounds* 6: 65–79.
39. Robson MC, Payne WG, Ko F, Mentis M, Donati G, et al. (2007) Hypochlorous acid as a potential wound care agent, Part II. *J Burns Wounds* 6: 80–90.
40. Pattison DI, Davies MJ (2001) Absolute rate constants for the reaction of hypochlorous acid with protein side chains and peptide bonds. *Chem Res Toxicol* 14: 1453–1464.
41. Pattison DI, Davies MJ (2006) Reaction of myeloperoxidase-derived oxidants with biological substrates: gaining chemical insight into human inflammatory diseases. *Curr Med Chem* 13: 3271–3190.
42. Hercegh A, Ghidan Á, Friedreich D, Gyurkovics M, Bedő Zs, Lohinai Zs (2013) Effectiveness of a high purity chlorine dioxide solution in eliminating intercanal *Enterococcus faecialis* biofilm. *Acta Microbiol Immunol Hung* 60(1): 63–75.
43. Pullar JM, Vissers MCM, Winterbourn CC (2000) Living with a killer: the effects of hypochlorous acid on mammalian cells. *IUBMB Life* 50: 259–266.
44. Pullar JM, Vissers MCM, Winterbourn CC (2001) Glutathione oxidation by hypochlorous acid in endothelial cells produces glutathione sulfonamide as a major product but not glutathione disulfide. *J Biol Chem* 276: 22120–22125.
45. Müller G, Kramer A (2006) Comparative study of in vitro cytotoxicity of povidone-iodine in solution, in ointment or in a liposomal formulation (Repithel) and selected antiseptics. *Dermatology* 212 Suppl 1: 91–3.
46. Müller G, Kramer A (2007) Revitalisierung von Säugerzellen nach Einwirkung von Antiseptika. (Revitalisation of mammalian cells exposed to antiseptics, in German) *GMS Krankenhaushyg Interdiszip.* 2007;2(2):Doc35. <http://www.egms.de/static/en/journals/dgkh/2007-2/dgkh000068.shtml> Accessed 15 April 2013.
47. Harwood DT, Kettle AJ, Winterbourn CC (2006) Production of glutathione sulfonamide and dehydroglutathione from GSH by myeloperoxidase-derived oxidants and detection using a novel LC–MS/MS method. *Biochem J* 399: 161–168.
48. Ogata N (2007) Denaturation of Protein by Chlorine Dioxide: Oxidative Modification of Tryptophane and tyrosine Residues. *Biochemistry* 46: 4898–4911.

# Supplementary Information

## A reaction-diffusion (RD) model for the transport of ClO<sub>2</sub> in a medium containing reactive proteins

### A general RD equation for ClO<sub>2</sub>

The following partial differential equation (usually called reaction-diffusion equation<sup>1</sup>) holds for the local ClO<sub>2</sub> concentration  $c$  ( $c$  is a function of the time  $t$  and of the space coordinates) when ClO<sub>2</sub> diffuses through a medium containing various components which can react with it:

$$\frac{\partial c}{\partial t} = -\sum_{i=1}^N R_i + D\nabla^2 c. \quad (S1)$$

In equation (S1)  $\frac{\partial c}{\partial t}$  is the time derivative of the local ClO<sub>2</sub> concentration,  $R_i$  is the rate of the ClO<sub>2</sub> consumption due to the  $i$ -th reaction at the same location,  $N$  is the number of the various ClO<sub>2</sub> consuming reactions,  $D$  is the diffusion coefficient of ClO<sub>2</sub> in the medium, and  $\nabla^2 c$  is the Laplacian of  $c$ , which – applying a three dimensional Descartes coordinate system with spatial coordinates  $x$ ,  $y$ , and  $z$  – can be written in the following form:

$$\nabla^2 c = \frac{\partial^2 c}{\partial x^2} + \frac{\partial^2 c}{\partial y^2} + \frac{\partial^2 c}{\partial z^2}. \quad (S2)$$

Equation (S1) is a balance equation for ClO<sub>2</sub> where the two terms on the right hand side stand, successively, for the effect of the chemical reactions and of diffusional transport<sup>1</sup>.

### A simplified RD equation for ClO<sub>2</sub>. The effective substrate concentration

As it was discussed previously there are four different amino acids and amino acid residues which can react with ClO<sub>2</sub> rapidly. In living tissue, however, there are even more chemical components<sup>2</sup> which are also able to react with ClO<sub>2</sub> by a slower but still measurable rate. A simple model cannot deal with all the ClO<sub>2</sub> reducing substrates of a complex biological system individually. To simplify the model the concept of the effective substrate concentration  $s$  will be introduced, which represents the local ClO<sub>2</sub> reducing capacity of all the various substrates in an integrated form.

To develop a definition for  $s$ , let us write the stoichiometry of the  $i$ -th reaction (the reaction of the  $i$ -th substrate  $S_i$  with ClO<sub>2</sub>) in the following simplified form:



The stoichiometric coefficient  $\nu_i$  shows how many ClO<sub>2</sub> moles can be reduced by one mole of  $S_i$ . For example, when the substrate contains an SH (sulfhydryl or thiol) group as cysteine does, the stoichiometric equation around pH 7 for a fast initial reaction<sup>3</sup> can be written as

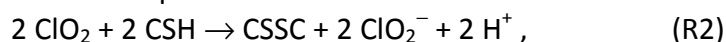

where CSH stands for cysteine and CSSC is its oxidation product, a disulfide, called cystine. (One of the products, ClO<sub>2</sub><sup>-</sup> (chlorite) is actually an intermediate because it can react further with cysteine, but only with a rate which is 6 orders of magnitude slower than the first step of the ClO<sub>2</sub>/CSH reaction<sup>3</sup>.) Thus, if we regard only the fast initial reaction then  $\nu_{\text{CSH}} = 1$ , because 1 mole CSH removes 1 mole ClO<sub>2</sub> in (R2). For tyrosine<sup>4</sup> and tryptophane<sup>5</sup>, a simplified scheme would suggest  $\nu_{\text{TYR}} = \nu_{\text{TRP}} = 2$ . Even in these relatively simple cases of pure amino acids, however, the effect of various parallel and consecutive reactions<sup>3,4,5</sup> can make it rather difficult to

calculate  $\nu$  very precisely, not to mention when these amino acids are residues in proteins or peptides.

For the definition of  $s$ , however, it is enough to assume that there is such a stoichiometric coefficient for each component. Then  $s$ , the effective substrate concentration of the medium, can be defined as a weighted sum of the individual  $s_i$  substrate concentrations, where  $\nu_i$  plays the role of a „weight factor“:

$$s = \sum_{i=1}^N \nu_i \cdot s_i . \quad (S3)$$

Moreover, as a further simplification, it will be assumed that  $R_i$ , the rate of  $\text{ClO}_2$  reduction due to the  $i$ -th reaction can be written as a bilinear function of  $s_i$  and  $c$ :

$$R_i = \nu_i \cdot k_i \cdot s_i \cdot c , \quad (S4)$$

where  $k_i$  is the second order rate constant of the  $i$ -th reaction. This way we assume that the rate determining step of the  $\text{ClO}_2$  – substrate reaction has second order kinetics. The assumption is certainly true for cystein, tyrosine and tryptophan substrates, as it was shown by Margerum's group<sup>3,4,5</sup>. Next, introducing an „effective rate constant“  $k$  by the definition:

$$k = \frac{\sum_{i=1}^N \nu_i \cdot k_i \cdot s_i}{\sum_{i=1}^N \nu_i \cdot s_i} , \quad (S5)$$

equation (S1) has the following simple form:

$$\frac{\partial c}{\partial t} = -k \cdot s \cdot c + D \nabla^2 c . \quad (S6)$$

### Simplified balance equations for fixed substrates

We will also assume all the substrates are fixed to the medium, and it is only the  $\text{ClO}_2$  which is able to diffuse. This approximation is reasonable, if the RD medium is a human or an animal tissue having a cellular structure. Amino acid residues are usually parts of large protein molecules, the diffusion of which is very slow. **Smaller peptides – especially glutathione – and free amino acids can diffuse but only within a cell because the outer membrane of the cell is not permeable for them. Thus, from the point of a long range transport through an animal or human tissue, even these small substrates can be regarded as fixed ones.** This way, the general RD equation for a substrate is

$$\frac{\partial s_i}{\partial t} = -k_i \cdot s_i \cdot c + D_i \nabla^2 s_i \quad (S7)$$

can be simplified to

$$\frac{\partial s_i}{\partial t} = -k_i \cdot s_i \cdot c \quad (S8)$$

as all  $D_i = 0$ . If we multiply both sides of equation (S8) with  $\nu_i$  and then summarize all such type of equations then we obtain the balance equation for the effective substrate concentration in the following simple form:

$$\frac{\partial s}{\partial t} = -k \cdot s \cdot c . \quad (S9)$$

When the medium contains the very reactive SH groups in a significant concentration then it can be proven that (S6) and (S9) can be simplified further: the form of the equations remains the same but the effective rate constant can be approximated as

$$k \approx k_{SH} \quad (S10)$$

where  $k_{SH}$  is the rate constant of the  $\text{ClO}_2 - \text{SH}$  group reaction, and the effective substrate concentration is

$$s \approx s_{SH} \quad (\text{S11})$$

where  $s_{SH}$  is the concentration of the sulfhydryl groups in the medium.

### Approximate solutions of the simplified RD equations

If the simplified RD equations (S6) and (S9) are accepted as a starting point, then the logical next step is to find a solution for these equations, that is to find the functions  $c=c(t,x,y,z)$  and  $s=s(t,x,y,z)$  while taking into account the given initial and boundary conditions. To find exact analytical solutions for nonlinear partial differential equations is usually not possible and in this work we did not want to apply numerical solutions either. Thus, our aim here should be to find and apply approximate solutions with simple mathematical formulas which can be easily applied for the interpretation of our experimental results.

One type of approximation can be applied when the rate constant  $k$  is very high, as in the case of substrates containing SH groups or tyrosine residues. In this case, a sharp reaction front propagates through the medium, and the solution of the reaction-diffusion problem can be approximated with „parabolic rate law” type equations.

The other approximation is valid for low  $k$  values. In this case, the smooth concentration profiles are determined mostly by the diffusion, and modified only slightly by the reaction which can be distributed in the whole medium (no sharp front). When the medium is finite, as in the case of a membrane, an approximate steady state can be reached after some transition time.

### **Quasi steady state solution of the RD equations when the $\text{ClO}_2 - \text{substrate}$ reaction is fast**

#### Preconditions of the parabolic rate law

The so-called parabolic rate law<sup>6</sup> holds for certain reaction-diffusion problems where the rate limiting step of an otherwise fast irreversible reaction (R3)



between the mobile reactant C and the fixed substrate S giving the product P is not the reaction itself but the diffusion of the reactant C to reach S. In our case C is  $\text{ClO}_2$  and S is the reactive side group of an amino acid. The most important reactant in this respect is the SH group of the cysteine<sup>3</sup>.

An important player in the process is the medium M immobilizing the substrate S but permeable for C at the same time. In our case the medium M is the hydrogel of the living tissues which is permeable for  $\text{ClO}_2$ . Lipid membranes of the cells in the tissue do not form barriers for  $\text{ClO}_2$  either, as it is very soluble in organic phases as well. The reactive amino acids, on the other hand – being mostly building blocks of various proteins – are immobilized in that hydrogel.

#### The parabolic rate law in one dimension for a slab of thickness $d$

The simplest geometry giving a parabolic rate law is a situation where the concentration of C is kept constant,  $[C] = c_0$  at the flat boundary of a slab e.g. at its left hand side, while  $[C] = 0$  at the right hand side of the slab. The material of the slab is a medium containing the fixed substrate S in a homogeneous initial concentration  $s_0$  (see Fig. S1). The thickness of the slab is  $d$ .

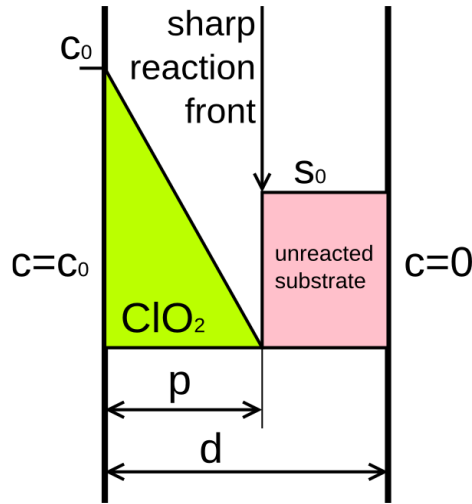

**Figure S1. Schematic  $\text{ClO}_2$  and substrate concentration profiles in a hydrogel slab of thickness  $d$  at an intermediate time  $t$  ( $0 < t < T$ ), where  $p$  is the penetration depth.**

When  $C$  is  $\text{ClO}_2$  and  $\text{ClO}_2$  is fed from one side of the slab, a sharp reaction front propagates from one side to the other. There is a measurable  $\text{ClO}_2$  concentration only behind the front thus disinfection of the slab is completed only when the reaction front reaches the other side of the slab. The characteristic time  $T$  required for that can be calculated by the parabolic rate law. The result:

$$T = \frac{s_0}{2c_0D} d^2 \quad \text{that is} \quad T \propto d^2. \quad (\text{S12})$$

That is the characteristic time  $T$  is proportional with the square of the thickness for a given set of non-geometrical parameters  $s_0$ ,  $c_0$ , and  $D$ . Here  $D$  is the diffusion coefficient of  $C$  in medium  $M$ . Alternatively, the penetration depth  $p$  of a sharp reaction is proportional with the square root of the time  $t$ :

$$p = \sqrt{\frac{2c_0D}{s_0}} \cdot \sqrt{t} \quad \text{that is} \quad p \propto \sqrt{t}. \quad (\text{S13})$$

Naturally the above formula gives the right  $p$  value only when  $t \leq T$  or when  $d$  is infinitely long.

#### Derivation of the parabolic rate law for a slab (or membrane)

As the concentration profile in Fig. S1 shows, it is assumed that the reaction occurs only in the plane  $x = p$ . This can be a good approximation if most of the reaction takes place in a narrow reaction zone much thinner than  $d$  (which is valid for a fast reaction combined with a relatively slow diffusion).

The  $\text{ClO}_2$  current  $I_C$  across the slab with cross-section  $A$  in the region  $0 < x < p$  can be given by Fick's law of diffusion:

$$I_C = -A \cdot D \cdot \frac{dc}{dx} \quad (\text{S14})$$

( $I_C$  is positive when the  $\text{ClO}_2$  flow points from left to right in Fig. S1).

In a quasi steady state

$$\frac{\partial c}{\partial t} \approx 0 \quad \frac{\partial c}{\partial t} = D \frac{\partial^2 c}{\partial x^2} \quad \Rightarrow \quad \frac{\partial^2 c}{\partial x^2} \approx 0 \quad \Rightarrow \quad \frac{\partial c}{\partial x} = \text{const}, \quad (\text{S15})$$

we can assume a linear concentration profile and so



$$I_c \approx A \cdot D \cdot \frac{c_0}{p}. \quad (\text{S16})$$

Next we can apply the component balance. If  $N_s$  is the mole number of the remaining S molecules in the volume  $V$  ( $N_s = s_0 V$ ) then we can write

$$\begin{aligned} \frac{dN_s}{dt} &= \frac{d(s_0 V)}{dt} = \frac{d(s_0 A(d-p))}{dt} = -I_c \\ -s_0 A \frac{dp}{dt} &= -A \cdot D \cdot \frac{c_0}{p} \Rightarrow p \frac{dp}{dt} = D \cdot \frac{c_0}{s_0} \\ \int_0^d p dp &= D \cdot \frac{c_0}{s_0} \int_0^T dt \Rightarrow \frac{d^2}{2} = D \cdot \frac{c_0}{s_0} \cdot T \Rightarrow \\ \Rightarrow T &= \frac{s_0}{2c_0 D} \cdot d^2 \end{aligned} \quad (\text{S17})$$

which is the parabolic rate law in one dimension for a slab.

The parabolic rate law for an infinitely long cylinder of radius  $R$

In this case, the characteristic time  $T$  is when the sharp reaction front starting from the surface propagating inward reaches the symmetry axis of the cylinder.

$$T = \frac{s_0}{4c_0 D} R^2 \quad \text{that is} \quad T \propto R^2 \quad (\text{S18})$$

We shall regard concentration distributions with cylindrical symmetry where the local concentration  $c$  is a function of the radius  $r$  only – that is  $c=c(r)$  – and independent of the azimuthal angle  $\varphi$  and the height  $z$ . In an analogy to the one dimensional case

$$I_c = -A \cdot D \cdot \frac{dc}{dr} = -2r\pi H \cdot D \cdot \frac{dc}{dr}, \quad (\text{S19})$$

where  $H$  is the height of the cylinder. We will assume a quasi steady state concentration in the zone of  $R > r > R-p$ , where  $p$  is the penetration depth. If  $I_c$  is independent of  $r$  in this region then

$r \cdot \frac{dc}{dr} = \text{const}$ . Regarding the boundary conditions:  $c(R-p) = 0$  and  $c(R) = c_0$  the steady state

concentration profile in this region can be written as:

$$c = c_0 \cdot \frac{\ln\left(\frac{r}{R-p}\right)}{\ln\left(\frac{R}{R-p}\right)}, \quad (\text{S20})$$

and

$$\frac{dc}{dr} = \frac{1}{r} \cdot \frac{c_0}{\ln\left(\frac{R}{R-p}\right)}. \quad (\text{S21})$$

Thus, with the above quasi steady state approximation

$$I_c = -2r\pi H \cdot D \cdot \frac{dc}{dr} \approx -2\pi H \cdot D \cdot \frac{c_0}{\ln\left(\frac{R}{R-p}\right)}. \quad (\text{S22})$$

The negative sign shows that  $I_c$  points inward: it is negative when  $\frac{dc}{dr} > 0$ .

Next we can apply the component balance. If  $N_S$  is the mole number of the remaining S molecules in the volume  $V$  ( $N_S = s_0 V$ ) then we can write

$$\begin{aligned} \frac{dN_S}{dt} &= \frac{d(s_0 V)}{dt} = \frac{d(s_0 H (R-p)^2 \pi)}{dt} = -|I_c| \\ -s_0 H \pi 2(R-p) \frac{dp}{dt} &= -2\pi H \cdot D \cdot \frac{c_0}{\ln\left(\frac{R}{R-p}\right)} \Rightarrow (R-p) \ln\left(\frac{R}{R-p}\right) \frac{dp}{dt} = D \cdot \frac{c_0}{s_0} \\ \int_0^R (R-p) \ln\left(\frac{R}{R-p}\right) dp &= D \cdot \frac{c_0}{s_0} \int_0^T dt \Rightarrow \frac{R^2}{4} = D \cdot \frac{c_0}{s_0} \cdot T \Rightarrow \\ \Rightarrow T &= \frac{s_0}{4c_0 D} \cdot R^2 \end{aligned} \quad (\text{S23})$$

The parabolic rate law in three dimensions for a sphere of radius R

$$T = \frac{s_0}{6c_0 D} R^2 \quad \text{that is} \quad T \propto R^2 \quad (\text{S24})$$

We shall regard concentration distributions with spherical symmetry where the local concentration  $c$  is a function of the radius  $r$  only – that is  $c=c(r)$  – and independent of the azimuthal angle  $\varphi$  and the polar angle  $\Theta$ . In an analogy to the one dimensional case,

$$I_c = -A \cdot D \cdot \frac{dc}{dr} = -4r^2 \pi \cdot D \cdot \frac{dc}{dr}. \quad (\text{S25})$$

We will assume a quasi steady state concentration in the zone of  $R > r > R-p$  where  $p$  is the penetration depth. If  $I_c$  is independent of  $r$  in this region, then  $r^2 \cdot \frac{dc}{dr} = \text{const}$ . Regarding the boundary conditions:  $c(R-p) = 0$  and  $c(R) = c_0$  the steady state concentration profile in this region can be written as:

$$c = c_0 \frac{R}{p} \left(1 - \frac{R-p}{r}\right), \quad (\text{S26})$$

and

$$\frac{dc}{dr} = c_0 \frac{R}{p} \cdot \frac{R-p}{r^2}. \quad (\text{S27})$$

Then with the quasi steady state approximation:

$$I_c = -4r^2 \pi \cdot D \cdot \frac{dc}{dr} \approx -4\pi \cdot D \cdot c_0 \frac{R}{p} \cdot (R - p). \quad (S28)$$

The negative sign shows again that  $I_c$  points inward: it is negative when  $\frac{dc}{dr} > 0$ .

Next we can apply the component balance. If  $N_S$  is the mole number of the remaining S molecules in the volume  $V$  ( $N_S = s_0 V$ ), then we can write

$$\begin{aligned} \frac{dN_S}{dt} &= \frac{d(s_0 V)}{dt} = \frac{d(s_0 4(R-p)^3 \pi / 3)}{dt} = -|I_c| \\ -s_0 \pi 4(R-p)^2 \frac{dp}{dt} &= -4\pi \cdot D \cdot c_0 \frac{R}{p} \cdot (R-p) \Rightarrow \frac{p(R-p)}{R} \frac{dp}{dt} = D \cdot \frac{c_0}{s_0} \\ \int_0^R \frac{p(R-p)}{R} dp &= D \cdot \frac{c_0}{s_0} \int_0^T dt \Rightarrow \frac{R^2}{6} = D \cdot \frac{c_0}{s_0} \cdot T \Rightarrow \\ \Rightarrow T &= \frac{s_0}{6c_0 D} \cdot R^2 \end{aligned} \quad (S29)$$

### Quasi steady state solution of the RD equation in one dimension when the $\text{ClO}_2$ – substrate reaction is slow

The one dimensional reaction-diffusion equation (RDE) in a steady state is

$$0 = -r + D \frac{d^2 c}{dx^2}, \quad (S30)$$

where  $r$  is the rate of the reaction (R4)

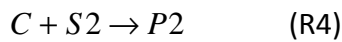

between the mobile reactant C and the fixed substrate  $S_2$  giving the product  $P_2$

$$r = k_2 \cdot c \cdot s_2. \quad (S31)$$

In this case, however, it will be assumed that the rate of the reaction is relatively slow and the substrate  $S_2$  is in such a great excess that its consumption can be neglected during the time of the measurement. That is

$$r \approx k_2 \cdot c \cdot (s_2)_0, \quad (S32)$$

and the steady state RDE:

$$\frac{d^2 c}{dx^2} = \frac{k_2 \cdot (s_2)_0}{D} \cdot c. \quad (S33)$$

If we introduce the following notation

$$\frac{k_2 \cdot (s_2)_0}{D} \equiv k^2,$$

then the steady state RDE has the following form:

$$\frac{d^2 c}{dx^2} = k^2 \cdot c. \quad (S34)$$

The general solution of the above differential equation is

$$c = c_1 \cdot e^{+k \cdot x} + c_2 \cdot e^{-k \cdot x}, \quad (S35)$$

where the integration constants  $c_1$  and  $c_2$  can be calculated from the boundary conditions:

$$c(0) = c_0 \quad \text{and} \quad c(d) = 0.$$

The solution regarding the above boundary conditions:

$$c = c_0 \frac{\text{sh}(k \cdot (d - x))}{\text{sh}(k \cdot d)}. \quad (\text{S36})$$

If the reaction is very slow, then the approximation

$$\text{sh}(\alpha) \approx \alpha \quad \text{if} \quad \alpha \ll 1 \quad (\text{S37})$$

can be applied and the steady state concentration profile obtained this way is the linear concentration profile valid for pure diffusion in the absence of any chemical reaction:

$$c = c_0 \left(1 - \frac{x}{d}\right). \quad (\text{S38})$$

The current density  $j$  of component C leaving the slab is maximal when there is no chemical reaction:

$$j_{MAX} = -D \frac{dc}{dx} = D \frac{c_0}{d}. \quad (\text{S39})$$

The current density is smaller if there is a slow reaction in the slab:

$$j_{RD} = -D \left( \frac{dc}{dx} \right)_{x=d} = D \cdot c_0 \frac{k}{\text{sh}(kd)}. \quad (\text{S40})$$

Finally, the ratio of the current densities is:

$$\frac{j_{RD}}{j_{MAX}} = \frac{kd}{\text{sh}(kd)}. \quad (\text{S41})$$

**Supplementary Table 1**

Data depicted in Figure 2.

$V$  is the cumulative volume of the 0.01 M  $\text{Na}_2\text{S}_2\text{O}_3$  titrant added until time  $t$ .

<b>1st exp</b>	<b>2nd exp</b>	
$t / s$	$t / s$	$V / \text{ml}$
0	0	0
540	140	0.5
630	202	1
695	252	1.5
752	294	2
809	326	2.5
855	366	3
876	403	3.5
915	440	4
955	476	4.5
995	507	5
1038	542	5.5
1078	575	6
1118	608	6.5
1153	642	7
1192	675	7.5
1226	708	8
1262	747	8.5
1299	782	9
1342	814	9.5
1374	847	10
1412	880	10.5
1450	908	11
1480	940	11.5
1518	972	12
1552	1004	12.5
1588	1038	13

**Supplementary Table 2**

Data depicted in Figure 3.

 $V$  is the cumulative volume of the 0.01 M  $\text{Na}_2\text{S}_2\text{O}_3$  titrant added until time  $t$ .

<b>1st day</b>	<b>2nd day</b>	<b>3rd day</b>	
t / s	t / s	t / s	V / ml
0	0	0	0
2490	530	250	0.5
2894	655	346	1
3198	750	418	1.5
3456	837	493	2
3670	916	568	2.5
3882	991	639	3
4080	1069	713	3.5
4273	1140	777	4
4452	1216	856	4.5
4636	1285	928	5
4812	1354	1003	5.5
4993	1420	1076	6
5171	1487	1147	6.5
5344	1556	1216	7
5522	1618	1286	7.5
5704	1680	1358	8
5889	1743	1427	8.5
6075	1810	1501	9
6266	1877	1579	9.5
6472	1942	1655	10
6658	2008	1734	10.5
6852	2077	1819	11
7059	2146	1894	11.5
	2218	1978	12
	2280	2061	12.5
	2346	2144	13
		2235	13.5

### Supplementary Table 3

Bacterial spectrum cultured from the wounds shown in Figures 4–6. Samples were taken when changing the bandage before applying ClO<sub>2</sub>.

Patient I.	at the admission	Pseudomonas aeruginosa Escherichia coli Enterococcus faecalis
	after 3 days	Proteus mirabilis
	after 14 days	Streptococcus alfa-hemoliticus
	after 28 days	Staphylococcus aureus
Patient II.	at the admission	Staphylococcus aureus
	after 1 week	no bacteria were found
	after 2 weeks	Corynebacterium species
Patient III.	at the admission	Staphylococcus aureus Gram negative rod
	after 1 week	no pathogens were found
	after 4 weeks	Morganella morganii

### Comments to Supplementary Table 3

i) As can be seen, due to the application of ClO<sub>2</sub> the bacterial flora changes. It can even disappear for a while (as in the case of Patient II and III) but usually only the species are replaced with different ones. The rate of wound healing, however, is not affected by the presence or the absence of certain bacteria according to our observations. This is in accordance with other authors' experience who report that the presence of micro-organisms at the wound site is neither deleterious to healing nor is it indicative that infection is inevitable<sup>7</sup>. For instance, 69 bacterial species were isolated in a study involving 58 patients with venous leg ulcers, none of them displaying clinical signs of infection<sup>8</sup>.

ii) James et al.<sup>9</sup> provided evidence that chronic wounds – unlike acute wounds – are colonised with biofilms. Microscopic analysis of debridement specimens from chronic wounds revealed the presence of densely aggregated microorganisms encapsulated in a protective matrix consistent with biofilms<sup>9</sup>. Most probably ClO<sub>2</sub> is promoting wound healing by killing all the bacteria on the surface including the ones living in biofilms. However, as the contact time of ClO<sub>2</sub> is short due to its volatility, it cannot prevent the reappearance of bacteria, but its periodic application prevents the formation of a new biofilm.

iii) It is worth mentioning that among the 50 patients treated with ClO<sub>2</sub> there were two cases where the wounds were colonized with MRSA and ClO<sub>2</sub> was able to decolonize and heal these wounds also.

## Supplementary References

- (1) Nicolis, G., De Wit, A. Reaction-diffusion systems *Scholarpedia* **2(9)**, 1475 (2007).  
[http://www.scholarpedia.org/article/Reaction-diffusion\\_systems](http://www.scholarpedia.org/article/Reaction-diffusion_systems)
- (2) Tan, H-K., Wheeler, W.B., Wei, C-I. Reaction of chlorine dioxide with amino acids and peptides: Kinetics and mutagenicity studies *Mutation Research/Genetic Toxicology* **188**, 259-266 (1987).
- (3) Ison, A., Odeh, I.N., Margerum, D.W. Kinetics and Mechanisms of Chlorine Dioxide and Chlorite Oxidations of Cysteine and Glutathione *Inorganic Chemistry* **45**, 8768-8775 (2006).
- (4) Napolitano, M.J., Green, B.J., Nicoson, J.S., Margerum, D.W. Chlorine Dioxide Oxidations of Tyrosine, *N*-Acetyltyrosine, and Dopa *Chem. Res. Toxicol.* **18**, 501-508 (2005).
- (5) Stewart, D.J., Napolitano, M.J., Bakhmutova-Albert E.V., Margerum, D.W. Kinetics and Mechanisms of Chlorine Dioxide Oxidation of Tryptophan *Inorganic Chemistry* **47**, 1639-1647 (2008).
- (6) House, J.E. Inorganic Chemistry *Academic Press*, p. 259 (2008). paragraph 8.2.2 The Parabolic Rate Law
- (7) Fernandez, M.: A longitudinal assessment of chronic wound fluid to detect biochemical indicators of healing, PhD Thesis, *Queensland University of Technology*, p. 17 (2010).
- (8) Hansson, C., Hoborn, J., Moller, A. and Swanbeck, G. The microbial flora in venous leg ulcers without clinical signs of infection. Repeated culture using a validated standardised microbiological technique. *Acta Derm. Venereol.* **75** (1) 24-30 (1995).
- (9) James, G.A., Swogger, E., Wolcott, R., Pulcini, P., Sestrich, J., Costerton, J.W. and Stewart, P.S. Biofilms in chronic wounds. *Wound Repair Regen.* **16** (1) 37-44 (2008).



## Mechanisms of Inactivation of Poliovirus by Chlorine Dioxide and Iodine

MARIA E. ALVAREZ AND R. T. O'BRIEN\*

*Department of Biology, New Mexico State University, Las Cruces, New Mexico 88003*

Received 1 February 1982/Accepted 17 June 1982

Chlorine dioxide and iodine inactivated poliovirus more efficiently at pH 10.0 than at pH 6.0. Sedimentation analyses of viruses inactivated by chlorine dioxide and iodine at pH 10.0 showed that viral RNA separated from the capsids, resulting in the conversion of virions from 156S structures to 80S particles. The RNAs released from both chlorine dioxide- and iodine-inactivated viruses cosedimented with intact 35S viral RNA. Both chlorine dioxide and iodine reacted with the capsid proteins of poliovirus and changed the pI from pH 7.0 to pH 5.8. However, the mechanisms of inactivation of poliovirus by chlorine dioxide and iodine were found to differ. Iodine inactivated viruses by impairing their ability to adsorb to HeLa cells, whereas chlorine dioxide-inactivated viruses were able to adsorb, penetrate, and initiate uncoating normally. Sedimentation analysis of extracts of HeLa cells infected with chlorine dioxide-inactivated viruses showed a reduced incorporation of [<sup>14</sup>C]uridine into new viral RNA. We concluded, then, that chlorine dioxide inactivated poliovirus by reacting with the viral RNA and impairing the ability of the viral genome to act as a template for RNA synthesis.

The importance of evaluating agents that offer alternatives to chlorine in the disinfection of water and wastewater has become evident. One of the main factors that has prompted interest in alternative disinfectants is that chlorine can react with organic matter to produce potentially hazardous compounds (10). Furthermore, it has been reported that chlorine-resistant enteroviruses have been isolated from finished drinking waters (20). Although the mechanisms of inactivation of viruses by halogens are not well understood, it has been suggested that compounds that destroy the biological activity of enteroviruses by damaging RNA would be superior to chlorine as disinfectants (21). Two virucidal agents that have not been extensively studied in terms of mechanisms of inactivation of viruses are chlorine dioxide and iodine. Chlorine dioxide has been shown to be at least as efficient as chlorine as a disinfectant (19). Although iodine has not been studied extensively as a virucidal agent, its efficiency as a bactericidal and virucidal agent has been recognized (5, 7). In this report, the mechanisms of inactivation of polio-

virus by chlorine dioxide and iodine are compared. The results indicate that chlorine dioxide

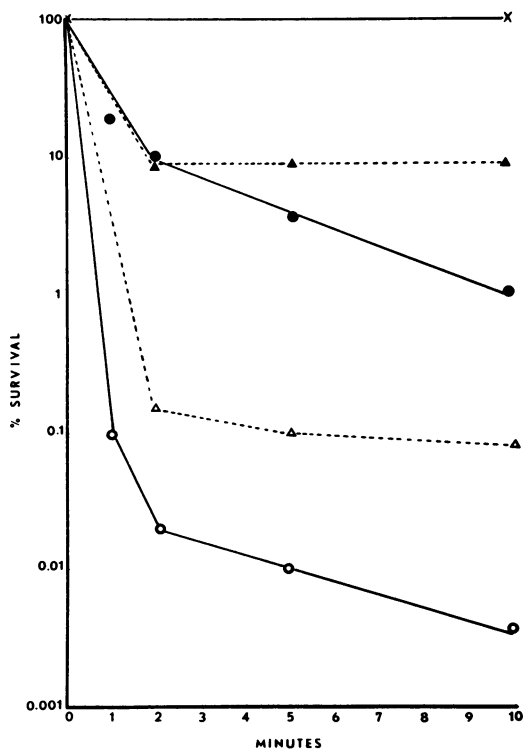

FIG. 1. Poliovirus inactivation by 1.0 mg of chlorine dioxide per liter or 2.5 mg of iodine per liter. Symbols: ●, chlorine dioxide at pH 6.0; ○, chlorine dioxide at pH 10.0; ▲, iodine at pH 6.0; △, iodine at pH 10.0; ×, untreated virus control at pH values 6.0 and 10.0.

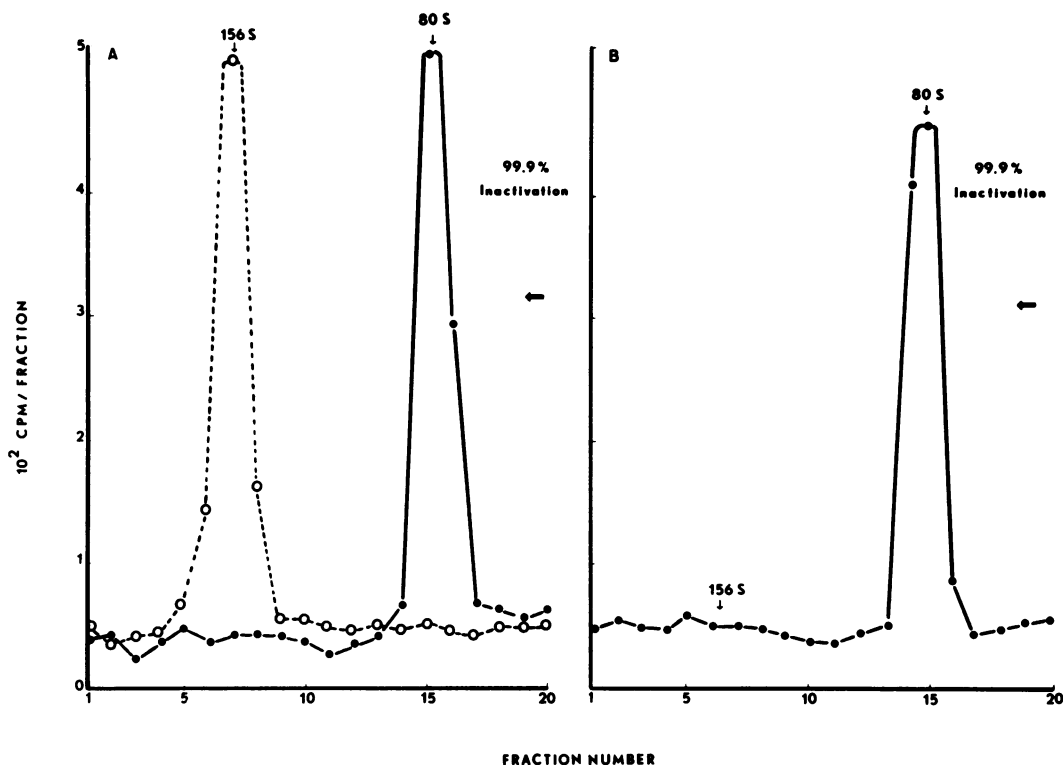

FIG. 2. Effects of chlorine dioxide and iodine on the sedimentation coefficients of capsid-labeled poliovirus at pH 10.0. Viruses were exposed to 1.0 mg of chlorine dioxide per liter for 1.0 min (A) or 2.5 mg of iodine per liter for 2.0 min (B) and then centrifuged at 30,000 rpm in 15 to 30% glycerol gradients for 3 h in an SW41 rotor. Control virus profile is shown by the dotted line. Direction of sedimentation is indicated by the horizontal arrows.

damages the RNA, whereas iodine reduces the ability of the virions to adsorb to host cells.

#### MATERIALS AND METHODS

**Virus preparation and cell lines.** Poliovirus type 1 (Mahoney) was used in this study. We used HeLa cell monolayers to propagate and assay the viruses. The methods for plaque assay, radioactive labeling, and purification of virus suspensions have been described previously (17).

**Preparation and analysis of halogen solutions.** Chlorine dioxide was generated and its concentrations were determined by the methods described by Roller et al. (18). Chlorine dioxide concentrations used in the experiments are indicated in the text. A 2.5% iodine solution in 50% ethanol-water was used as the source of iodine. Iodine concentrations were determined by the diethyl-*p*-phenylene diamine method (12), which was modified for small volumes by the addition of 0.04 g of total halogen reagent to appropriately diluted iodine solutions in final volumes of 5.0 ml of glass-distilled water. Iodine concentrations used in inactivation experiments are indicated in the text.

**Virus inactivation experiments.** Halogen demand-free 0.05 M phosphate buffer (pH 6.0) and halogen

demand-free 0.05 M borate buffer (pH 10.0) were used as suspending media for inactivation experiments. The final reaction volumes ranged from 1.0 to 3.0 ml, and all inactivation experiments were done at 25°C. The desired concentrations of halogen solutions were added to buffered virus suspensions containing  $10^7$  to  $10^8$  PFU/ml. At the end of the exposure times, residual halogen was inactivated by adding 0.1 to 0.3 ml of a 0.1% solution of sodium thiosulfate.

**Sedimentation and isoelectric focusing of viruses.** The procedures used for determination of the sedimentation characteristics of viruses and viral components and the isoelectric focusing techniques have been described previously (22).

**Binding of  $^{125}\text{I}$  to poliovirus.** Elemental  $^{125}\text{I}$  (150 mCi/mmol) was purchased from New England Nuclear Corp. and diluted to 90,000 cpm/ml (450,000 dpm) in unlabeled iodine stock solutions containing 25 mg of iodine per liter. Iodine binding and inactivation experiments were performed by adding 0.1 ml of stock halogen solution to 0.9 ml of buffer containing  $10^7$  PFU of poliovirus, followed by sedimentation analysis as described above.

**Virus adsorption and penetration-uncoating experiments.** The adsorption of halogen-inactivated viruses to HeLa cells was determined by infecting each HeLa cell monolayer (ca. 14 cm<sup>2</sup>) with 0.2 ml of control or

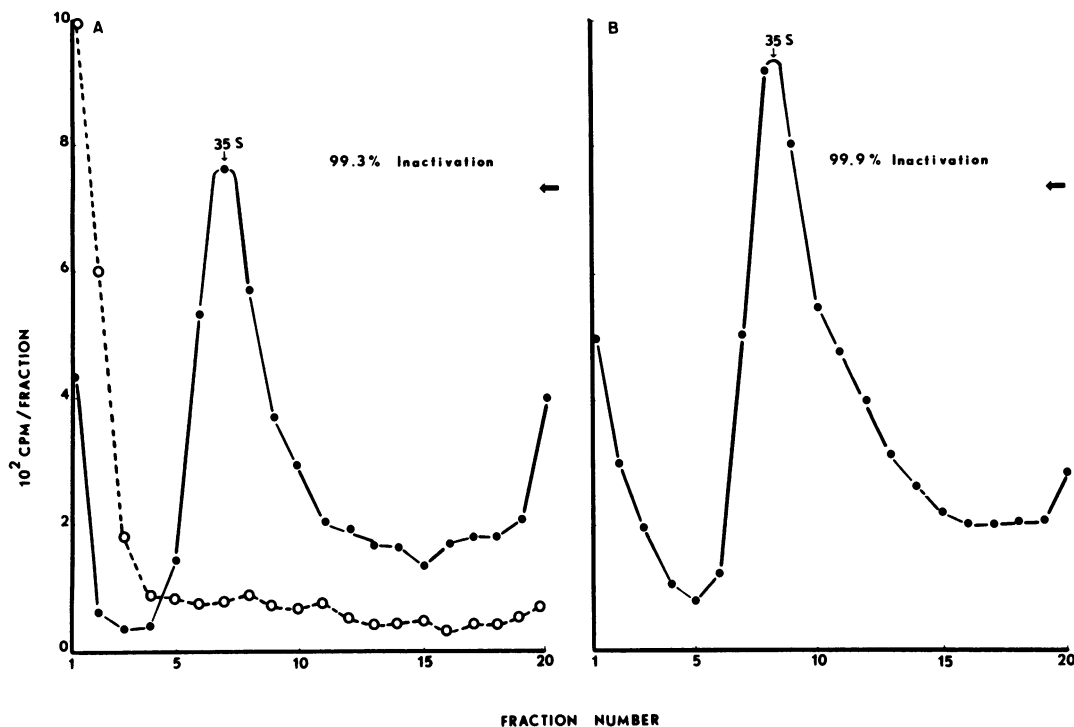

FIG. 3. Effects of chlorine dioxide and iodine at pH 10.0 on the sedimentation characteristics of poliovirus RNA. Viruses with labeled RNAs were exposed to 1.0 mg of chlorine dioxide per liter for 1.0 min (A) or 2.5 mg of iodine per liter for 2.0 min (B), and then the virus suspensions were centrifuged at 65,000 rpm in 5 to 30% glycerol gradients for 90 min in an SW65 rotor. Control virus profile is shown by the dotted line. Direction of sedimentation is indicated by the horizontal arrows.

halogen-inactivated, capsid-labeled virus suspension. After a 30-min adsorption period at 37°C, the monolayers were rinsed five times with phosphate-buffered saline. The cells were removed with trypsin-EDTA (GIBCO Laboratories), and the cell suspensions were cooled to 4°C by adding an equal volume of phosphate-buffered saline. The cells were sedimented by centrifugation at 8,000 rpm for 20 min, the pellets were suspended in 0.4 ml of 0.01% sodium dodecyl sulfate, and the cells were disrupted by sonication at 30 W for 10 s. Each disrupted cell suspension was added to 10.0 ml of scintillation cocktail, and the amount of radioactivity in each sample was counted in a liquid scintillation spectrometer. Adsorption of viruses to cells was determined by measuring cell-associated radioactivity. The virus penetration-uncoating experiments were performed similarly, except that the virions were allowed to interact with the cells for up to 60 min at 37°C. After the cells were removed and disrupted as described above, the samples were layered onto 15 to 30% glycerol gradients and centrifuged for 3 h at 30,000 rpm in an SW41 rotor at 4°C. The gradients were fractionated, and the fractions were analyzed by liquid scintillation spectrometry.

**Effects of chlorine dioxide on poliovirus RNA synthesis.** Each HeLa cell monolayer (14 cm<sup>2</sup>) was infected with 0.5 ml of a control or chlorine dioxide-inactivated virus sample. After 30 min, 5.0 ml of minimal essential medium containing 5% newborn calf serum was added,

and the cultures were incubated at 37°C for 90 min. The medium was then replaced with 5.0 ml of minimal essential medium containing 5% newborn calf serum, 5.0 µg of actinomycin D per ml, and 0.5 µCi of [<sup>14</sup>C]uridine (53-mCi/mmol specific activity) per ml. The cultures were incubated for 3 h at 37°C to allow for the incorporation of the [<sup>14</sup>C]uridine into new viral RNA molecules. The [<sup>14</sup>C]uridine-containing medium was decanted, the monolayers were washed five times with phosphate-buffered saline, and the cells were removed with trypsin and centrifuged as described above. After suspension of the pellet in 0.3 ml of buffer (0.005 M Tris, 0.0005 M EDTA, 0.05 M NaCl, pH 7.5), sodium dodecyl sulfate was added to a final concentration of 0.01%. Since the cells were lysed by this treatment, the sonication step was omitted to avoid possible breakage of the newly synthesized viral RNA molecules. The lysed cells were layered onto preformed 5 to 30% glycerol gradients which were centrifuged at 40,000 rpm for 5 h at 4°C in an SW41 rotor. The gradients were fractionated, and the total counts per minute in all fractions were determined by liquid scintillation spectrometry.

## RESULTS

**Effect of pH on inactivation.** It has been reported that chlorine dioxide is more effective as a

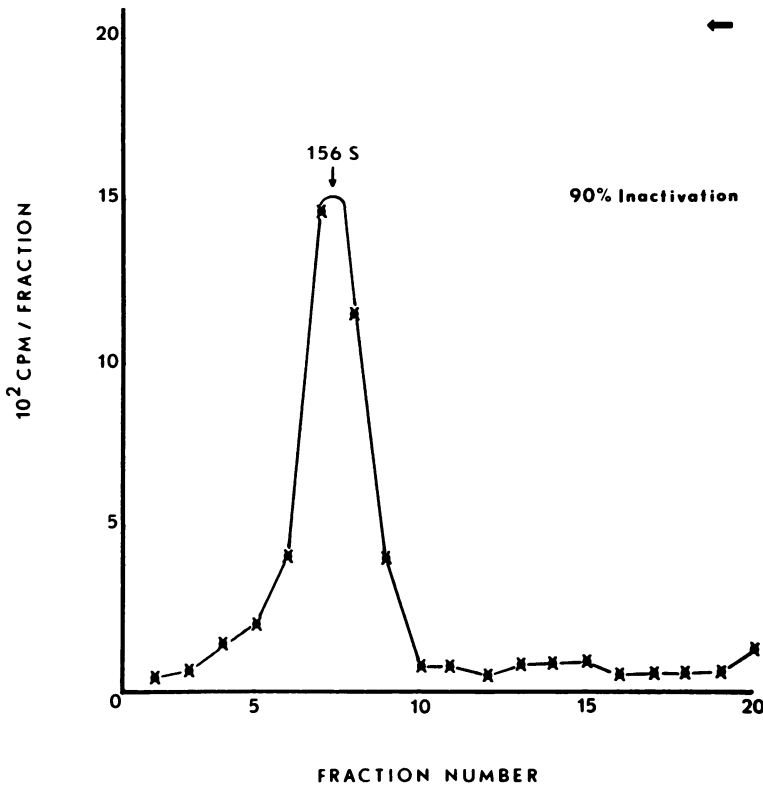

FIG. 4. Effects of chlorine dioxide and iodine on the sedimentation coefficients of poliovirus with labeled capsids at pH 6.0. Viruses were exposed for 2.0 min to 1.0 mg of chlorine dioxide per liter (●) or 2.5 mg of iodine per liter (×) and then centrifuged at 30,000 rpm in 15 to 30% glycerol gradients for 3 h in an SW41 rotor. Direction of sedimentation is indicated by the horizontal arrow.

virucidal agent at alkaline pH values (19). Our data agreed with these findings: we found that chlorine dioxide at a concentration of 1.0 mg/liter inactivated poliovirus more efficiently at pH 10.0 than at pH 6.0 (Fig. 1). Like chlorine dioxide, iodine also was more virucidal at pH 10.0 than at pH 6.0. The results indicate, however, that chlorine dioxide was a more efficient virucidal agent than iodine.

**Effects of chlorine dioxide and iodine on virus composition.** We observed effects on virus structure similar to those previously reported for chlorine (17): inactivation of poliovirus by 1.0 mg of chlorine dioxide per liter or 2.5 mg of iodine per liter at pH 10.0 resulted in the separation of the RNA from the capsids and the consequent conversion of the virions from 156S structures to 80S particles (Fig. 2). The RNAs released from chlorine dioxide- or iodine-inactivated viruses sedimented at the same position as 35S viral RNA (Fig. 3). At pH 6.0, exposure of poliovirus to 1.0 mg of chlorine dioxide per liter or 2.5 mg of iodine per liter for 2.0 min did not result in the loss of RNA from the capsids, and

the viruses sedimented as 156S structures, although 90% of the virus population was inactivated (Fig. 4). It was reported previously for chlorine that the separation of viral components did not correlate with inactivation (1). These results indicated that the loss of RNA from the capsids of poliovirus is not the cause of inactivation. Consequently, experiments on the nature of virus inactivation by chlorine dioxide and iodine were done under conditions which minimized virus structural damage. For testing iodine, the experiments were done with solutions containing <1.0 mg of halogen per liter at pH 10.0. For testing chlorine dioxide, the experiments were done with solutions of 1.0 mg of halogen per liter at pH 6.0, at which the inactivation rate was slower (Fig. 1), since concentrations of <1.0 mg of chlorine dioxide per liter were difficult to determine reliably. In addition, the inactivated virus preparations were centrifuged in 15 to 30% glycerol gradients, and the fractions containing only 156S particles were used. A sensitive method for determining capsid alterations is isoelectric focusing. Accordingly,

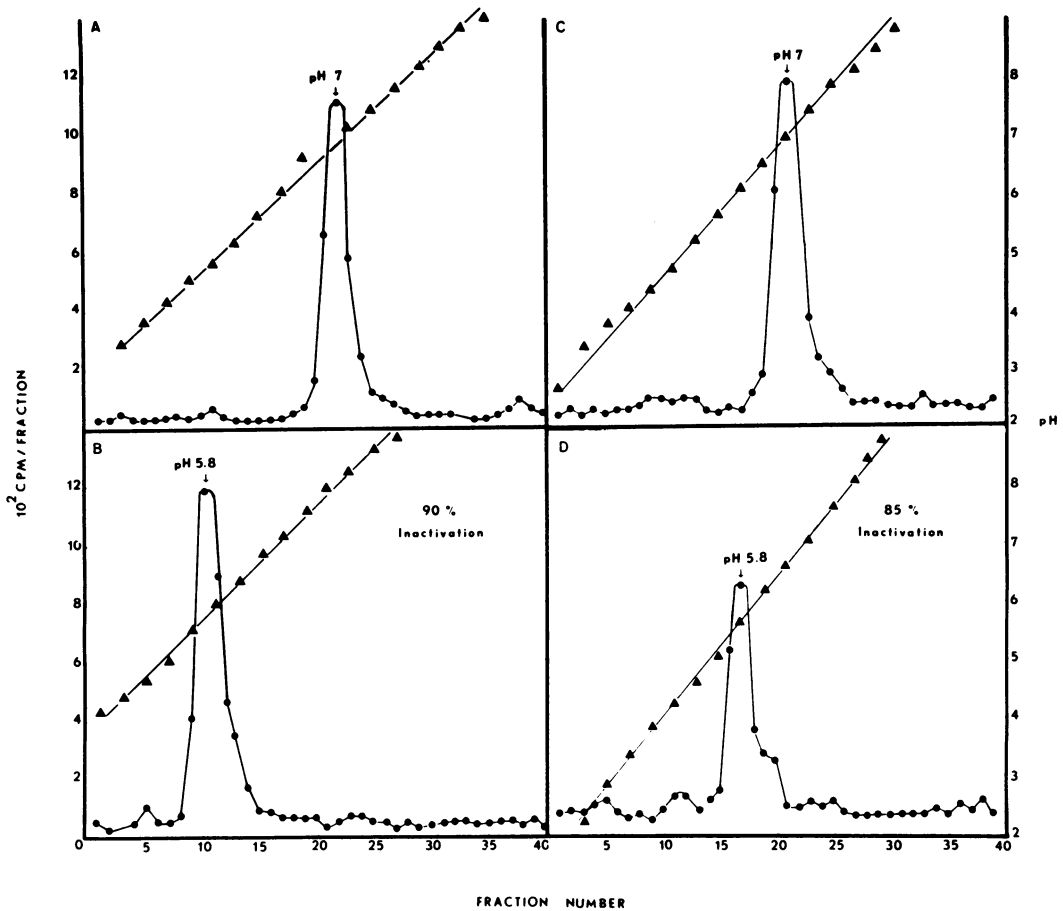

FIG. 5. Effects of chlorine dioxide and iodine on poliovirus pI values. Viruses with labeled capsids were exposed to 1.0 mg of chlorine dioxide per liter at pH 6.0 for 2 min (B) or 0.8 mg of iodine per liter at pH 10.0 for 15 min (D). The virus suspensions were then centrifuged in 15 to 30% glycerol gradients for 3 h at 30,000 rpm in an SW41 rotor. The gradient fractions containing 156S virus particles were pooled and focused in sucrose gradients. (A and C) pI values for control viruses. Direction of migration during isoelectric focusing was from right to left. The pH gradient is shown ( $\blacktriangle$ ).

the pI values of inactivated virions were compared with those of infective viruses. The pI values for both the chlorine dioxide- and iodine-inactivated virions were irreversibly shifted from pH 7.0 to pH 5.8 (Fig. 5). According to Mandel (15), heat-treated poliovirus with a stabilized pI value of pH 4.5 can not adsorb to host cells. Therefore, the adsorption to HeLa cells of viruses with altered pI values was compared with the adsorption of control virions. Chlorine dioxide-inactivated virions adsorbed to HeLa cells as efficiently as did control viruses (Table 1). In contrast to these results, the data clearly show that iodine-inactivated viruses had impaired adsorption capabilities and that the reduced adsorption correlated with the amount of inactivation. Thus, chlorine dioxide and iodine

inactivated poliovirus by different mechanisms, although the effects on the pI values were similar.

In view of the effects of iodine on the adsorption of polioviruses to host cells, it was of interest to determine if iodine became associated with the virus particles. Accordingly,  $^{125}\text{I}$  was added to iodine solutions used to inactivate unlabeled polioviruses. After the viruses were exposed to the halogen, the samples were analyzed by rate zonal centrifugation in 15 to 30% glycerol gradients as described above. Results of these experiments are shown in Fig. 6, which shows that no  $^{125}\text{I}$  became associated with the viruses.

Since chlorine dioxide-inactivated viruses adsorbed to HeLa cells as efficiently as did control

TABLE 1. Effects of chlorine dioxide and iodine on poliovirus adsorption to HeLa cells<sup>a</sup>

Virus treatment	Halogen concn (mg/liter)	Adsorption of inactivated virus <sup>b</sup>	% Reduction in adsorption of inactivated virus <sup>c</sup>	% Inactivation <sup>d</sup>
Control	0	100	0	0
Chlorine dioxide	1.0	100	0	90
Iodine	0.4	60	40	50
Iodine	0.8	13	87	97

<sup>a</sup> HeLa cells were infected with viruses with labeled capsids. Adsorption was determined by measuring viral radioactivity associated with the host cells.

<sup>b</sup> Expressed as values relative to control virus adsorption as 100%.

<sup>c</sup> Expressed as values relative to reduction in control virus adsorption as 0%.

<sup>d</sup> Percent reduction in PFU after exposure to indicated concentration of halogen.

viruses, experiments to determine the ability of chlorine dioxide-inactivated viruses to penetrate into HeLa cells and initiate the uncoating process were done. The gradient profiles of lysed cells infected with control or chlorine dioxide-treated virus are presented in Fig. 7, and it is evident that there were no differences between control and inactivated viruses. In these experiments, the early modified and further modified articles described by DeSena and Torian (8) were observed in gradient profiles of cells infected with control or chlorine dioxide-inactivated virus.

Since no differences were detected in the adsorption, penetration, or uncoating between chlorine dioxide-treated virus and control virus, the possibility that chlorine dioxide reacted with viral RNA was considered. Although RNA released from chlorine dioxide-inactivated virus was found to cosediment with intact viral RNA (Fig. 2), the possibility still remained that the molecule had suffered damage not detectable by sedimentation analysis. Accordingly, experiments were done to determine the ability of the RNA from inactivated virions to direct the incorporation of [<sup>14</sup>C]uridine into new viral RNA. Control or chlorine dioxide-inactivated virions were allowed to adsorb to HeLa cells, penetrate, uncoat, and initiate RNA replication. Actinomycin D was added at the same time as [<sup>14</sup>C]uridine to stop DNA-directed RNA synthesis, thus assuring that the radioactive label was incorporated into viral RNA. The infected cells were lysed, and the newly synthesized viral RNA containing [<sup>14</sup>C]uridine was then analyzed by rate zonal centrifugation and liquid scintilla-

tion spectrometry. Less [<sup>14</sup>C]uridine were incorporated into new RNA molecules by chlorine dioxide-treated samples than by controls (Table 2). Furthermore, the percent reduction (determined by the total number of counts per minute incorporated into viral RNA) correlated reasonably well with the percent inactivation value.

## DISCUSSION

The results presented in this report show that separation of the RNA from the capsids of poliovirus occurred under conditions that enabled more efficient inactivation by chlorine dioxide and iodine. The same phenomenon has also been reported for poliovirus inactivation by chlorine and bromine chloride (14, 17). Therefore, under appropriate conditions, the separation of viral components appears to be a generalized phenomenon of enterovirus inactivation by halogens. However, in no case does separation of viral components appear to be the cause of virus inactivation.

Iodine and chlorine dioxide were found to inactivate poliovirus more efficiently at pH 10.0 than at pH 6.0. The nature of the most active species of these compounds in disinfection has not been studied in detail. However, chlorine

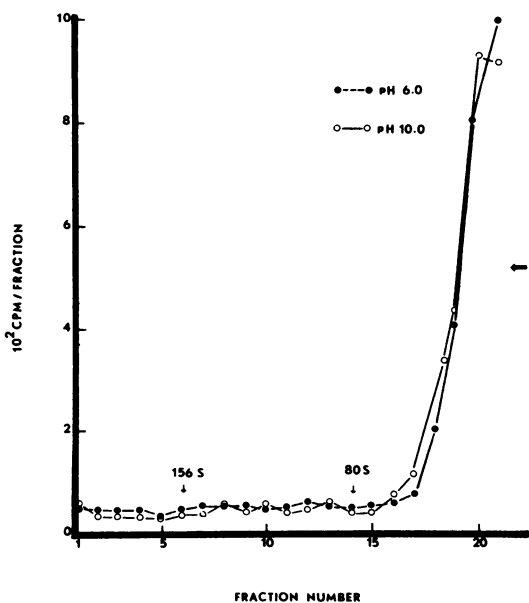

FIG. 6. Binding of <sup>125</sup>I by iodine-inactivated polioviruses. Viruses were suspended in a solution of 2.5 mg of iodine per liter containing <sup>125</sup>I. Virus suspensions were centrifuged in 15 to 30% glycerol gradients at 30,000 rpm for 3 h at 4°C in an SW41 rotor. Positions of 156S and 80S particles are shown. Direction of sedimentation is indicated by the horizontal arrow.

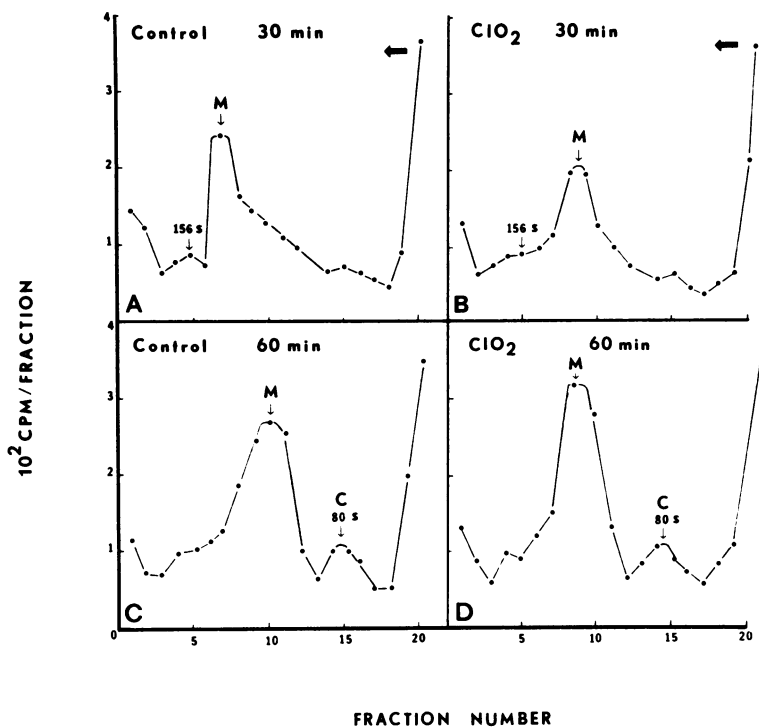

FIG. 7. Effects of chlorine dioxide on uncoating of poliovirus with labeled capsids in HeLa cells. Virus suspensions were inactivated 90% in solutions of 1.0 mg of chlorine dioxide per liter at pH 6.0 for 2.0 min. HeLa cells were infected with control or inactivated virus, and at the indicated times, the cells were lysed, and the cell extracts were centrifuged in 15 to 30% glycerol gradients for 3 h at 30,000 rpm in an SW41 rotor. The positions of the early modified (M) and further modified (C) particles are shown. Direction of sedimentation is indicated by the horizontal arrows.

dioxide has been reported to remain undissociated in aqueous solutions at pH values from 4.0 to 8.4 (2). In an alkaline solution it disproportionates to chlorite ( $\text{ClO}_2^-$ ) and chlorate ( $\text{ClO}_3^-$ ) via the following reaction:  $2\text{ClO}_2 + 2\text{OH}^- \rightleftharpoons \text{H}_2\text{O} + \text{ClO}_2^- + \text{ClO}_3^-$  (8). Since the end product formed as a result of the oxidation of organic matter by undissociated chlorine dioxide is the  $\text{ClO}_2^-$  ion (9, 16), it is possible that  $\text{ClO}_3^-$  is the most active species in inactivation of poliovirus at alkaline pH levels. However, according to Chen (6), the amount of  $\text{ClO}_2^-$  or  $\text{ClO}_3^-$  formed as the result of the disproportionation of  $\text{ClO}_2$  at pH 10 is less than 5%. It is not clear at the present time whether this amount of chlorite or chlorate is sufficient to account for the increase in the rate of inactivation of poliovirus observed at pH 10.0. An alternative explanation would be that the high pH increases the sensitivity of the virus to  $\text{ClO}_2$  attack. In iodine solutions at pH 10.0, more than 88% of the iodine is in the form of hypoiodous acid (HIO), whereas at pH 6.0, 90% of the iodine is in the form of elemental iodine (3). Thus, it appears

that the most active species of iodine in virus inactivation is the HIO molecule.

It is not surprising, then, that chlorine dioxide and iodine inactivate poliovirus by different mechanisms. Our results indicate that when HIO was the inactivating agent, the ability of the viruses to adsorb to host cells was impaired. Since the percent inactivation values correlated well with the percent reduction in adsorptive capabilities, we suggest that HIO reacts with the protein coat of the virus and not with the RNA. This proposal is in agreement with the findings of Hsu, who reported that poliovirus and phage f2 RNAs are fully resistant to iodine (13). The reactions of HIO with the protein coat of poliovirus appear to be oxidative rather than substitutive since we found no evidence of  $^{125}\text{I}$  binding to polioviruses. Iodine has been shown to act on other proteins and viruses by oxidation of sulfhydryl groups, which results in little or no binding of the halogen (11).

Brigano et al. suggested that chlorine dioxide at pH 7.0 inactivates viruses by denaturing the protein coat (4). However, this hypothesis was

TABLE 2. Incorporation of [<sup>14</sup>C]uridine into viral RNA in HeLa cells infected with control or chlorine dioxide-inactivated poliovirus in the presence of actinomycin D<sup>a</sup>

Cultures treated with:	% [ <sup>14</sup> C]uridine incorporation <sup>b</sup>	% Reduction of [ <sup>14</sup> C]uridine incorporation <sup>c</sup>	% Virus inactivation <sup>d</sup>
Nothing	0	— <sup>e</sup>	—
Infective virus	8	—	—
Inactivated virus	2.5	69	88

<sup>a</sup> Poliovirus suspensions were inactivated with chlorine dioxide before HeLa cells were infected. We added 5 µg of actinomycin D per ml and [<sup>14</sup>C]uridine to infected cell cultures simultaneously.

<sup>b</sup> Determined from the ratio counts per minute of [<sup>14</sup>C]uridine incorporated into RNA:total counts per minute of [<sup>14</sup>C]uridine added.

<sup>c</sup> Expressed as percentage of [<sup>14</sup>C]uridine incorporated by cells infected with inactivated viruses/percentage of [<sup>14</sup>C]uridine incorporated by cells infected with infective viruses.

<sup>d</sup> Percent reduction in PFU by chlorine dioxide.

<sup>e</sup> —, 0% reduction.

based on thermodynamic analysis of inactivation curves rather than on structural and functional analysis of inactivated viruses. Our results for inactivation at pH 6.0 indicate that, although chlorine dioxide reacts with the protein coat and changes the pI, the critical target appears to be the viral RNA, which is less capable of acting as a template for viral RNA replication. The possibility that the mechanism for poliovirus inactivation at pH 10.0 differs from the mechanism for inactivation at pH 6.0 cannot be eliminated by the present results.

It has been suggested that the most effective virucidal compounds used for water disinfection should inactivate the viral genome (21). Our results, then, indicate that chlorine dioxide may be a good primary or secondary disinfectant since viral RNA appears to be the critical target at pH 6.0. Clearly, further studies on the nature of virus inactivation by halogen compounds are needed if more effective virucidal agents are to be developed.

#### ACKNOWLEDGMENTS

This work was supported by funds provided through the New Mexico Water Resources Research Institute by the Office of Water Research and Technology, U.S. Department of the Interior, as authorized under the Water Resources Research Act of 1964, Public Law 88-379, under project A-066.

#### LITERATURE CITED

- Alvarez, M. E., and R. T. O'Brien. 1982. Effects of chlorine concentration on the structure of poliovirus. *Appl. Environ. Microbiol.* **43**:237-239.
- Benarde, M. A., B. M. Israel, V. P. Olivieri, and M. L. Granstrom. 1965. Efficiency of chlorine dioxide as a bactericide. *Appl. Microbiol.* **13**:776-780.
- Black, A. P., W. C. Thomas, R. N. Kinman, W. P. Bonner, M. A. Keirn, J. J. Smith, and A. A. Jabero. 1968. Iodine for the disinfection of water. *J. Am. Water Works Assoc.* **60**:69-83.
- Brigano, F. A. O., P. V. Scarpino, S. Cronier, and M. L. Zink. 1979. Effects of particulates on inactivation of enteroviruses in water by chlorine dioxide, p. 86-92. In A. D. Venosa (ed.), *Progress in wastewater disinfection technology*. Environmental Protection Agency publication no. EPA-600/9-79-018. Environmental Protection Agency, Cincinnati, Ohio.
- Chang, S. L., and J. C. Morris. 1953. Elemental iodine as a disinfectant for drinking water. *Ind. Eng. Chem.* **45**:1009-1012.
- Chen, T. 1967. Spectrophotometric determination of microquantities of chlorate, chlorite, hypochlorite, and chlorine in perchlorate. *Anal. Chem.* **39**:804-813.
- Cramer, W. N., K. Kawata, and C. W. Kruse. 1976. Chlorination and iodination of poliovirus and f2. *J. Water Pollut. Control Fed.* **48**:61-76.
- DeSena, J., and B. Torian. 1980. Studies on the *in vitro* uncoating of poliovirus. *Virology* **104**:149-163.
- Dodgen, H., and H. Taube. 1949. The exchange of chlorine dioxide with chlorite ion and with chlorine in other oxidation states. *J. Am. Chem. Soc.* **71**:2501-2504.
- Environmental Protection Agency. 1979. The chemistry of disinfectants in water: reactions and products. Environmental Protection Agency publication no. PB-292-776. Environmental Protection Agency, Washington, D.C.
- Fraenkel-Conrat, H. 1955. The reaction of tobacco mosaic virus with iodine. *J. Biol. Chem.* **217**:373-381.
- Hach Chemical Company. 1975. *Water and wastewater analysis procedures*, 2nd ed., p. 54. Hach Chemical Company, Ames, Iowa.
- Hsu, Y. 1964. Resistance of infectious RNA and transforming DNA to iodine which inactivates f<sub>2</sub> phage and cells. *Nature (London)* **203**:152-153.
- Keswick, B. H., R. S. Fujioka, and P. C. Loh. 1981. Mechanism of poliovirus inactivation by bromine chloride. *Appl. Environ. Microbiol.* **42**:824-829.
- Mandel, B. 1971. Characterization of type 1 poliovirus by electrophoretic analysis. *Virology* **44**:554-568.
- Myhrstad, J. A., and J. E. Samdal. 1969. Behavior and determination of chlorine dioxide. *J. Am. Water Works Assoc.* **61**:205-208.
- O'Brien, R. T., and J. Newman. 1979. Structural and compositional changes associated with chlorine inactivation of poliovirus. *Appl. Environ. Microbiol.* **38**:1034-1039.
- Roller, S. D., V. P. Olivieri, and K. Kawata. 1980. Mode of bacterial inactivation by chlorine dioxide. *Water Res.* **14**:635-641.
- Scarpino, P. V., F. A. O. Brigano, S. Cronier, and M. L. Zink. 1979. Effect of particulates on disinfection of enteroviruses in water by chlorine dioxide. Environmental Protection Agency publication no. EPA-600/2-79-054. Environmental Protection Agency, Cincinnati, Ohio.
- Shaffer, P. T. B., T. G. Metcalf, and O. J. Sproul. 1980. Chlorine resistance of poliovirus isolants recovered from drinking water. *Appl. Environ. Microbiol.* **40**:1115-1121.
- Tenno, K. M., R. S. Fujioka, and P. C. Loh. 1979. The mechanism of poliovirus inactivation by hypochlorous acid, p. 665-675. In R. Jolley, W. A. Brungs, and R. B. Cumming (ed.), *Proceedings of the Third Conference on Water Chlorination: environmental impact and health effects*. Ann Arbor Science Publishers, Inc., Ann Arbor, Mich.
- Yeager, J. G., and R. T. O'Brien. 1979. Structural changes associated with poliovirus inactivation in soil. *Appl. Environ. Microbiol.* **38**:702-709.



# Mechanisms of Inactivation of Hepatitis A Virus by Chlorine

Jun Wen Li,\* Zhong Tao Xin, Xin Wei Wang, Jin Lai Zheng, and Fu Huan Chao

*Institute of Health and Environmental Medicine of Tianjin, Tianjin City 300050, People's Republic of China*

Received 4 February 2002/Accepted 29 July 2002

**The study was intended to investigate the feasibility of reverse transcription-PCR (RT-PCR) for evaluation of the efficacy of inactivation of viruses in water and to elucidate the mechanisms of inactivation of hepatitis A virus (HAV) by chlorine. Cell culture, enzyme-linked immunosorbent assay, and long-overlap RT-PCR were used to detect the infectivity, antigenicity, and entire genome of HAV inactivated or destroyed by chlorine. The cell culture results revealed the complete inactivation of infectivity after 30 min of exposure to 10 or 20 mg of chlorine per liter and the highest level of sensitivity in the 5' nontranslated regions (5'NTR), inactivation of which took as much time as the inactivation of infectivity of HAV by chlorine. However, antigenicity was not completely destroyed under these conditions. Some fractions in the coding region were resistant to chlorine. To determine the specific region of the 5'NTR lost, three segments of primers were redesigned to monitor the region from bp 1 to 1023 across the entire genome. It was shown that the sequence from bp 1 to 671 was the region most sensitive to chlorine. The results suggested that the inactivation of HAV by chlorine was due to the loss of the 5'NTR. It is believed that PCR can be used to assess the efficacy of disinfection of HAV by chlorine as well as to research the mechanisms of inactivation of viruses by disinfectants.**

Hepatitis A virus (HAV) is a positive-strand RNA virus that belongs to the *Hepatovirus* group of the family *Picornaviridae*, which can bring about infectious hepatitis (hepatitis A). The infection rate of HAV is universally very high, being about 70% in China (18), and person-to-person spread of HAV is also very common. Disinfection with chlorine has been adopted worldwide to ensure the safety of drinking water, since HAV spreads mainly through drinking water and food. However, research on the mechanisms of chlorine inactivation of HAV has been inadequate. It is generally believed that chlorine inactivates HAV by damaging the nucleic acid of the virus (2, 3, 12). With the development of molecular biology methods, nucleic acid probes and PCR have been used to evaluate the effects of virus disinfection and to research disinfection mechanisms. However, the research problem most frequently encountered and difficult to solve is that, after disinfection, the virus nucleic acid can still be detected by PCR, although the infectivity of the virus actually no longer exists. Therefore, it is generally believed that molecular biology methods cannot be used to evaluate either the effects or the mechanisms of disinfection (2, 8, 9, 16).

The assumption that chlorine acts on the virus nucleic acid is likely to be measured by PCR. The main reason why no ideal result has ever been obtained in previous studies is that the length of the virus nucleic acid segment detected is limited and fails to reflect the overall status of viral nucleic acid. So in this study, in addition to using such techniques as cell culture and enzyme-linked immunosorbent assay (ELISA) to detect infectivity and antigenicity of virus, a large section of step-by-step shifting (long overlap) reverse transcription-PCR (RT-PCR) has been applied to make a full sequence. This technique thus made it possible to scan for HAV nucleic acids before and after

disinfection in order to define the mode, area, and characteristics of chlorine's activity on HAV nucleic acid and thus lay a foundation for research on the effects and mechanisms of disinfection.

## MATERIALS AND METHODS

**Virus strains.** The strain of HAV used in this study was Nj-3, isolated from the human liver cancer cell line PLC/PRF/5 (both were donated by the Institute of Military Medical Research of Nanjing).

**Propagation and purification of virus.** The methods used for proliferation and purification of virus were described previously by Peterson et al. (13) and Shieh et al. (15). All cell cultures were grown in Eagle's minimum essential medium (Difco Laboratories, Detroit, Mich.) containing 8% fetal bovine serum (FBS), 0.015 M HEPES buffer, and antibiotics (50 µg [each] of kanamycin and gentamicin per ml) and maintained in the same medium with 1.5% FBS. For virus propagation and isolation, cell cultures in 75-cm<sup>2</sup> flasks were drained of medium, inoculated with small volumes of stock virus, and inoculated for 1 h at 37°C with periodic rocking for viral adsorption. Cultures were then supplemented with maintenance medium and incubated at 35°C for viral propagation. Medium was replaced for 2 to 3 days of incubation. HAV was harvested by freezing and thawing, concentrated with 12% (wt/vol) polyethylene glycol, and further purified by dialysis with ultracentrifugation in CsCl equilibrium gradients. The details were described by Wang et al. (16).

**Extraction of virus RNA.** A virus RNA extraction kit made by Life Technologies for extraction of exceedingly pure viral RNA was utilized in our experiment to extract virus RNA, and all operations were strictly implemented in accordance with the reagent instruction manual.

**Primer design for assay of HAV nucleic acid.** Seven sets of primers were designed with Oligo 4.0 software on the basis of published reports on several strains of HAV sequences (1, 13). Each set of the primers contains three strips of primers: S and A are the first PCR primers, and SN is a seminested PCR primer. The first PCR products are around 1,000 bp, with adjacent primers on top of another, so that a full-sequence scanning of HAV nucleic acid could be carried out (Table 1). All primers were synthesized and purified by the Dalian Bao Biology Company.

**Amplification of HAV nucleic acid by RT-PCR.** The one-step single-tube RT-PCR reagent used in the experiment was purchased from the Bao Biology Company, and the specific operations were carried out in line with the reagent instruction manual. The RT-PCR parameters are listed as follows. RT was performed at 50°C for 30 min. Pre-denaturation was performed at 94°C for 5 min. This was followed by denaturation at 94°C for 1 min, annealing at 60°C for 45 s, and extension at 72°C for 1 min for 35 cycles and, finally, extension at 72°C for 10 min. Next, 1 µl of RT-PCR-expanded product, diluted at a ratio of 1:10, was taken for the seminested PCR to verify the particularity of the expanded

\* Corresponding author. Mailing address: Institute of Health and Environmental Medicine of Tianjin, 1 Da Li Rd., Tianjin City 300050, People's Republic of China. Phone: 86-22-84655345. Fax: 86-22-23328809. E-mail: junwenli@eyou.com.

TABLE 1. Primer sequences and their locations in the entire genome of HAV

Primer name and properties <sup>a</sup>	Locations	Sequence	Product length (bp)
<b>I</b>			
S	1~18	TTCAAGAAGGGTCTCCGG	
A	1002~1023	GAGCATGTGTAGTAAGCCAATC	1,023
SN	652~671	AAGGCCCAAAGAAGAGTCC	671
<b>II</b>			
S	997~1020	CTGCAGATTGGCTTACTACACATG	
A	2033~2056	TACTCACCTTTCTGTTGTGCTGAC	1,060
SN	1556~1577	TGCTTTGGATCAGGAAGATTGG	521
<b>III</b>			
S	2045~2067	GAAAGGTGAGTACACTGCCATTG	
A	3191~3215	AGGAGGTGGAAGCACTTCATTGTA	1,171
SN	2713~2734	GTTGGGTAGAGAAGGAGTCAGC	503
<b>IV</b>			
S	3040~3059	AATGTCAGCTGGAGACTTGG	
A	4166~4185	TTGTCGTCTTCAATGGC	1,146
SN	3642~3661	GGATTGTCTGGAGTTCAGGA	544
<b>V</b>			
S	4101~4122	GTGAATTATGGCAAGAAGAAGG	
A	5329~5348	CACCAACTCCAACTGAACC	1,249
SN	4629~4648	GTGTCAGGATGTCCAATGAG	620
<b>VI</b>			
S	5327~5346	CTGGTTCAGTTGGAGTTGG	
A	6494~6513	AAAGGACAAGCATCAATGGC	1,187
SN	5976~5995	GTTCAATGAATGTGGTCTCC	538
<b>VII</b>			
S	6496~6515	CATTGATGCTTGTCTTTGG	
A	7478~poly(A)	TTTTTTTTTTTTTTT	985
SN	6696~6715	CCAGTCTTAGTCCATTATG	785

<sup>a</sup> S, upstream primer; A, downstream primer; SN, seminested primer.

product. The reaction conditions were the same as those for the one-step single-tube RT-PCR, but with 15 cycles.

**Detection of PCR product.** To detect PCR products, an agarose gel electrophoresis method (11) was used. Amplification reaction mixtures (10  $\mu$ l) were mixed with 2  $\mu$ l of 6 $\times$  gel loading buffer and loaded onto 2% agarose gels. After electrophoresis, gels were soaked in 5  $\mu$ g of ethidium bromide per ml for 5 min and destained for 1 h. The bands were then visualized and photographed.

**Preparation and analysis of halogen solutions.** Chlorine demand-free water was prepared according to Peterson's methods (13). All reagents and buffers used in chlorination experiments were prepared with chlorine demand-free water. Chlorine solution was made by dissolving the chlorine gas, liberated by the action of concentrated HCl on potassium permanganate, in dilute NaOH. The stock chlorine solution was stored in amber-colored bottles at 4°C. The concentration was defined by iodometry before being used.

**Chlorine inactivation experiments.** For chlorine inactivation, the glassware was thoroughly cleaned and rinsed with chlorine demand-free water. The chlorine demand of the HAV solution was determined by the *N,N*, diethyl-*p*-phenyldiamine (DPD) colorimetric method to be 0.5 to 0.6 mg/liter. The bulk volume of the overall reaction system of the disinfection experiment was 10 ml, of which virus-containing original liquid and disinfectant occupied 1 ml, respectively. The rest of the volume was filled by sterilized phosphate-buffered saline. The treatment solution was prepared at pH 7.0 with the desired free residual chlorine at 5, 10, 20, and 50 mg/liter plus 0.6 mg/liter to satisfy the demand of the HAV solution, and the exposure times were 10, 30, and 60 min. The rest of the chlorine was neutralized by 1% Na<sub>2</sub>S<sub>2</sub>O<sub>3</sub>.

**Test of virus infectivity.** After disinfection, samples at every time point were used to inoculate cells, and the titer of infectivity was determined (6, 11) in terms of the 50% tissue culture infective dose (TCID<sub>50</sub>) per milliliter. The following equation was used to calculate the infectivity/inactivation ratio of virus.

Rate of inactivation (%) =

$$\frac{\text{TCID}_{50}/\text{ml of control group} - \text{TCID}_{50}/\text{ml of disinfection group}}{\text{TCID}_{50}/\text{ml of control group}} \times 100\%$$

**Antigenicity measured by ELISA.** In this study, we used anti-HAV antibodies containing a human polyclonal anti-HAV serum collected after natural infection and a rabbit monoclonal anti-HAV antibody. To quantify antigenicity, an ELISA

TABLE 2. Inactivation of infectivity of HAV at different chlorine dosages and exposure times<sup>a</sup>

Chlorine dosage (mg/liter)	Inactivation in TCID <sub>50</sub> /ml (%) at exposure time:		
	10 min	30 min	60 min
5	10 <sup>5.63</sup> (24.14)	10 <sup>5.33</sup> (61.98)	10 <sup>4.78</sup> (89.29)
10	10 <sup>4.50</sup> (94.38)	0 (100)	0 (100)
20	10 <sup>3.78</sup> (98.93)	0 (100)	0 (100)

<sup>a</sup> The initial concentration of HAV was 10<sup>5.75</sup> TCID<sub>50</sub>/ml. The inactivation rate of virus infectivity is shown in parentheses.

method was used. A 96-well microtiter plate coated with polyclonal anti-HAV antibody was used for the assay. HAV was serially diluted, loaded, and incubated overnight at room temperature. After being washed five times, horseradish peroxidase-labeled anti-HAV antibody was added for 1 h at 37°C. Microtiter plates were washed, and the optical density at 450 nm (OD<sub>450</sub>) was measured.

## RESULTS

**Inactivation of virus infectivity.** When the chlorine concentration is 5 mg/liter, HAV infectivity still cannot be completely inactivated, despite exposure for 60 min. Only with a chlorine concentration of 10 or 20 mg/liter and after an exposure time of 30 min can HAV infectivity be inactivated completely (Table 2).

**Destructibility of virus antigenicity.** When the chlorine concentration is 5 or 10 mg/liter, HAV antigenicity still exists (OD<sub>450</sub> for the experimental group/OD<sub>450</sub> for the control group, >2.0), even after exposure for 60 min. The antigenicity was not destroyed completely by a chlorine dosage of 20 mg/liter. Only with a chlorine concentration of 20 mg/liter and after exposure for 60 min did HAV antigenicity become negative (Table 3).

**Inactivation of virus nucleic acid. (i) Amplification of HAV nucleic acid by PCR before disinfection.** Positive results can be tested through large-section, step-by-step shifting RT-PCR for the virus nucleic acid in a positive control group (Fig. 1), and its specificity was confirmed by the seminested PCR (data not shown).

**(ii) Detection of virus nucleic acid after chlorine disinfection. (a) Full-sequence scanning results for virus nucleic acid.** When the chlorine concentration was 10 mg/liter with exposure for 30 min, the RT-PCR product of the I primers was negative. It is shown that chlorine acts on HAV nucleic acid best within the range of amplification area of the I primers, near the 5' nontranslated region (5'NTR) of the virus nucleic acid (Fig. 2). This result is consistent with that from inactivation of virus infectivity. Besides, the 3'NTR of the nucleic virus was also negative when the chlorine concentration was 10 mg/liter with

TABLE 3. Destructibility of virus antigenicity at different chlorine dosages and exposure times

Chlorine dosage (mg/liter)	Destructibility (P/N ratio) at exposure time <sup>a</sup> :		
	10 min	30 min	60 min
5	5.17	5.09	4.85
10	4.87	3.21	2.01
20	3.49	2.98	1.57

<sup>a</sup> The initial P/N value of HAV was 5.23; a P/N value below 2.0 means that the antigenicity was destroyed completely. P is the OD<sub>450</sub> for the experimental group, and N is the OD<sub>450</sub> for the control group.

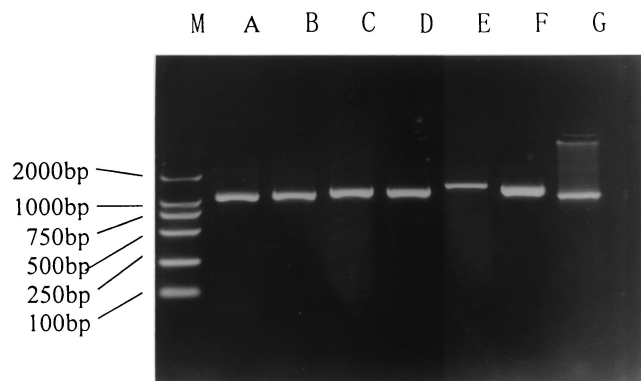

FIG. 1. RT-PCR results for the scanned entire genome of HAV. Lanes: M, DNA marker; A to G, amplification with the outer primers I to VII, respectively.

exposure for 60 min, while the coding area of the virus nucleic acid revealed stronger resistance to chlorine (Table 4).

**(b) Amplification results for the sensitive area of virus nucleic acid.** The structure of the 5'NTR in HAV nucleic acid is very complicated. The amplification area (bp 1 to ~1023) of the I primer pair is further divided into three jointed sections according to the composition characteristics of HAV genome in order to find the specific position of chlorine action. The primer sequence and amplification areas are listed in Table 5.

Take exposure to 10 mg of chlorine per liter for 30 min as an example. The amplification was made segment by segment for the 5'NTR, and a strict control procedure was set up. The result showed that two segments (bp 1 to ~174 and 155 to ~671) tested negative with contact with the disinfectant for 30 min; the segment from bp 669 to ~1023 was positive, and the three segments of the positive control groups were all positive (Fig. 3).

**DISCUSSION**

Inactivation of infectivity is the most important and direct index with which to evaluate the effects of viral disinfection. Previously, different experimental designs had led to different

TABLE 4. Detection of infectivity and nucleic acid of HAV disinfected with chlorine

Group	Infectivity <sup>a</sup>	RT-PCR results of the entire genome						
		I	II	III	IV	V	VI	VII
Control	+	+	+	+	+	+	+	+
5 mg/liter	30 min	+	N <sup>b</sup>	N	N	N	N	N
	60 min	+	+	+	+	+	+	+
10 mg/liter	30 min	-	-	+	+	+	+	+
	60 min	-	-	+	+	+	+	-
20 mg/liter	30 min	-	-	+	-	+	+	-
	60 min	-	-	-	-	+	+	-
50 mg/liter	60 min	-	-	-	-	+	-	-

<sup>a</sup> +, positive; -, negative.  
<sup>b</sup> N, not detected.

results in studies of chlorine inactivation of HAV. For example, with 30 min of exposure, the effective chlorine concentrations required by different researchers were between 1 and 25 mg/liter (14, 17). Our study found that HAV could be inactivated when the chlorine concentration exceeds 10 mg/liter with 30 min of exposure time.

Because it is fast, sensitive, specific, and simple to operate, ELISA has often been adopted to evaluate the effects of HAV inactivation. Our study suggests that the antigenicity of virus can be inactivated when the chlorine concentration is 10 mg/liter with an exposure time of 60 min, which means that the disappearance of antigenicity comes after the inactivation of infectivity. This result agrees with the study by Scarpino et al. (14). It is suggested that the original target of chlorine inactivation in HAV may not be in the capsid protein of virus, but rather in the nucleic acid.

Nucleic acid probes and PCR have been used to evaluate viral disinfection and to study the disinfection mechanisms. For

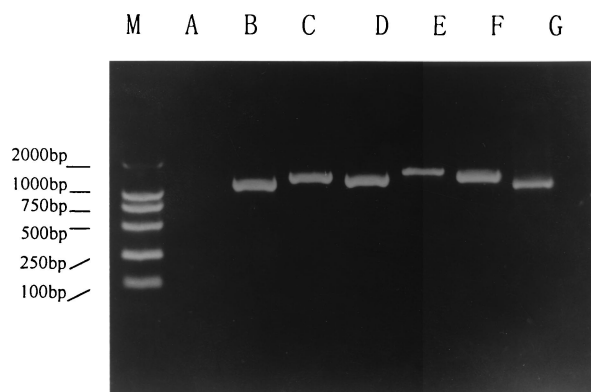

FIG. 2. Results of the scanned entire genome of HAV after 30 min of disinfection with a 10-mg/liter dosage of chlorine. Lanes: M, DNA marker; A to G, amplification with the outer primers I to VII, respectively.

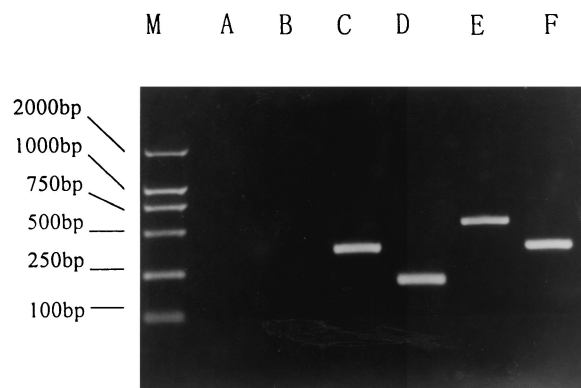

FIG. 3. Amplification of the 5'NTR at 10 mg of chlorine per liter for 30 min. Lanes: M, DNA marker; A and D, bp 1 to ~174; B and E, bp 155 to ~671; C and F, bp 669 to ~1023. Lanes A, B, and C represent the tested groups, and lanes D, E, and F represent the control group.

TABLE 5. Primers designed to amplify the near 5'NTR of HAV

Primer	Location	Sequence	Length (bp)	Amplified region
S	1~18	TTCAAGAAGGGTCTCCGG		
A <sup>a</sup>	155~174	AGAACCCAGAACCTGCAGGA	174	Before IRES
S <sup>a</sup>	155~173	TCTGCAGGTTCTGGGGTTCT		
A	652~671	AAGGCCCAAAGAACAGTCC	517	IRES
S <sup>a</sup>	669~688	CCTTATGTGGTGTTTGCCTC		
A	1002~1023	GAGCATGTGTAGTAAGCCAATC	355	Structure region

<sup>a</sup> Newly redesigned primer.

example, Leveque et al. have discovered that when HAV in seawater is irradiated by UV radiation for 60 min, HAV exhibits no infectivity, but its nucleic acid can still be detected by RT-PCR (8). Han et al. reached a similar conclusion (4). In addition, different disinfection methods for inactivation of poliovirus have been studied. Reports by Moore and Margolin (11) showed that neither a nucleic acid probe nor RT-PCR could determine the inactivation of poliovirus when used to detect virus nucleic acid after the virus had been treated with chlorine, chlorine dioxide, ozone, and UV radiation. Ma et al., Maier et al., and Moore and Margolin believe that although the infectivity of poliovirus cannot be tested by cell culture, its nucleic acid can still be revealed by RT-PCR when the virus is treated with UV radiation, free chlorine, HCl, and NaOH (9–11). They all agreed that evaluations of the effect or mechanism of disinfection cannot be carried out accurately with RT-PCR or a nucleic acid probe.

However, as is known to all, PCR is a kind of reaction that has strong particularity and strict requirements for template DNA. Any chemical change in the link of the template DNA chain, including a chain rupture, and any chemical change on base groups, such as an alkali base or pentose, can result in unmatched template and primers or failure to extend and replicate after mating, and hence no amplification. Therefore, the effects of disinfectant on the DNA can be fully reflected by the PCR results. The results mentioned above occur because of the adoption of inappropriate PCR methods where the length of target nucleic acid segment was only around 100 to ~400 bp, while the length of nucleic acid of HAV or poliovirus is about 7,500 bp. It follows that the changes in the nucleic acid segment of several tenths alone cannot achieve an objective evaluation of the effect of disinfectant for the whole length of the virus nucleic acid.

Large-fragment step-by-step shift RT-PCR was used in our study to make a full sequence scanning on HAV nucleic acid before and after disinfection. It has been found that different positions of the virus nucleic acid showed different levels of resistance to chlorine—the 5'NTR and 3'NTR are more sensitive to chlorine, whereas the coding area shows more resistance to chlorine. The 5'NTR segment could not be detected

by PCR when the infectivity of virus was inactivated completely, meaning that the inactivation of virus infectivity is consistent with its damage, but some fragments of the coding area can still be detected, which is what researchers have neglected in their previous studies and made mistakes with.

The functions of the 5'NTR in HAV nucleic acid are complex and can be classified as related sequence of virus replication (REP), an area rich in pyrimidine (pY1), an internal ribosome entry site (IRES), and an area between pY1 and the IRES (5, 7) (Fig. 4). To more precisely locate the specific sites of chlorine action on HAV nucleic acid, the sections of 5'NTR have been further shortened. It has been found that virus nucleic acid can still be detected in the region of bp 669 to ~1023, while the positions at bp 1 to ~174 and 155 to ~671 are negative according to many tests after virus infectivity is inactivated. It is thus evident that the segment running from bp 1 to ~671 of the 5'NTR plays an important role in the inactivation of virus infectivity. For the tiny RNA virus family, this area has a stable stem-loop structure close to the 5' end (near the 10th nucleotide). The protein signal identification needed by virus replication depends on the space structure of the sequence in this area, and the identification of the signal will be affected by inactivation of the nucleic acid of this area. The IRES contains the *cis*-form action elements, which are required by external translation, and HAV protein translation requires the combination of various translation original genes with IRES. The expression of virus protein will be much affected by the failure to carry out the combination effectively (7). Therefore, the 5'NTR is closely associated with replication of virus RNA, the origination of translation, and the composition of the virus particles. Chlorine inactivation of HAV is just the result of inactivation of the virus nucleic acid 5'NTR. It is believed that the inactivation effect of disinfectant on virus can be evaluated completely by PCR in terms of the mechanism of inactivation of HAV nucleic acid by chlorine.

#### REFERENCES

- Cohen, J. I., J. R. Ticehurst, R. H. Purcell, A. Buckler-White, and B. M. Barody. 1987. Complete nucleotide sequence of wild-type hepatitis A virus: comparison with different strains of hepatitis A virus and other picornaviruses. *J. Virol.* **61**:50–59.
- Dennis, W. H., V. P. Olivieri, and C. W. Krause. 1979. The reaction of nucleotides with aqueous hypochlorous acid. *Water Res.* **13**:357–362.
- Dennis, W. H., V. P. Olivieri, and C. W. Krause. 1979. Mechanism of disinfection: incorporation of Cl-36 into f<sub>2</sub> virus. *Water Res.* **13**:363–369.
- Han, Y. Q., M. L. Zhang, R. F. Yang, T. M. Chen, and Y. J. Liu. 1996. Study on the relationship between PCR detection results and infectivity of HAV. *Chin. J. Disinfect.* **13**:133–137.
- Harmon, S. A., O. C. Richards, D. F. Summers, and E. Ehrenfeld. 1991. The 5'-terminal nucleotides of hepatitis A virus RNA, but not poliovirus RNA, are required for infectivity. *J. Virol.* **65**:2757–2760.
- Huang, J., W. Li, N. Ren, F. Ma, and L. Ju. 1997. Disinfection effect of

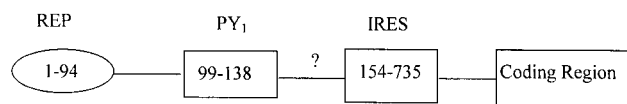

FIG. 4. Diagram of sequences in the HAV 5'NTR proposed for different functions (7). The numbers indicate the nucleotide sequences of pHAV/7. REP, replication-related sequence.

- chlorine dioxide on viruses, algae and animal planktons in water. *Water Res.* **31**:455–460.
7. **Jia, X.-Y., M. Tesar, D. F. Summers, and E. Ehrenfeld.** 1996. Replication of hepatitis A virus with chimeric 5' nontranslated regions. *J. Virol.* **70**:2861–2868.
  8. **Leveque, L., J. M. Crance, C. Beril, and L. Schwartzbrod.** 1995. Virucidal effect of UV light on hepatitis A virus in seawater: evaluation with cell culture and RT-PCR. *Water Sci. Technol.* **31**:157–160.
  9. **Ma, J.-F., T. M. Straub, I. L. Pepper, and C. P. Gerba.** 1994. Cell culture and PCR determination of poliovirus inactivation by disinfectants. *Appl. Environ. Microbiol.* **60**:4203–4206.
  10. **Maier, A., D. Tougianidou, A. Wiedenmann, and K. Botzenhart.** 1995. Detection of poliovirus by cell culture and by PCR after UV disinfection. *Water Sci. Technol.* **31**:141–145.
  11. **Moore, N. J., and A. B. Margolin.** 1994. Efficacy of nucleic acid probes for detection of poliovirus in water disinfected by chlorine, chlorine dioxide, ozone, and UV radiation. *Appl. Environ. Microbiol.* **60**:4189–4191.
  12. **O'Brien, R. T., and J. Newman.** 1979. Structural and compositional changes associated with chlorine inactivation of polioviruses. *Appl. Environ. Microbiol.* **38**:1034–1039.
  13. **Peterson, D. A., T. R. Hurley, J. C. Hoff, and L. G. Wolfe.** 1983. Effect of chlorine treatment on infectivity of hepatitis A virus. *Appl. Environ. Microbiol.* **45**:223–227.
  14. **Scarpino, P. V., G. Berg, S. L. Chang, D. Dahling, and M. Lucas.** 1972. A comparative study of the inactivation of viruses in water by chlorine. *Water Res.* **6**:959–965.
  15. **Shieh, Y. S. C., R. S. Baric, M. D. Sobsey, J. Ticehurst, T. A. Miele, R. Deleon, and R. Walter.** 1991. Detection of hepatitis A virus and other enteroviruses in water by ssRNA probes. *J. Microbiol. Methods* **31**:119–136.
  16. **Wang, C. H., S. Y. Tschen, and B. Flehming.** 1995. Antigenicity of hepatitis A virus after ultraviolet inactivation. *Vaccine* **13**:835–840.
  17. **Wang, F., Z. Liang, and Z. Yang.** 1995. Comparative study of chlorine on the HAV antigen and infectivity. *Chin. J. Disinfect.* **12**:94–96.
  18. **Wang, J. X., Y. F. Yu, Z. Y. Xu, and S. Z. Yu.** 1998. The pathogenological evidence of hepatitis A translated by *Hairy clam*. *Lett. Shanghai Med. Coll.* **15**:384–386.

# Investigation on virucidal activity of chlorine dioxide. Experimental data on Feline calicivirus, HAV and Coxsackie B5

R. ZONI, R. ZANELLI, E. RIBOLDI, L. BIGLIARDI, G. SANSEBASTIANO  
Department of Public Health, Sec. Hygiene, University of Parma, Italy

## Key words

Chlorine dioxide • Virucidal activity • Disinfection treatment

## Summary

**Introduction.** The aim of this study was to evaluate the efficacy of  $\text{ClO}_2$  with regard to viruses which show a particular resistance to oxidizing agent such as HAV and Norwalk and Norwalk-like viruses, and which play an important role in the epidemiology of viral foodborne diseases.

In the food industry, disinfection of processing systems and equipment is a very important instrument to prevent secondary contamination and to guarantee food safety. Among disinfectants, chlorine dioxide ( $\text{ClO}_2$ ) presents a good efficacy at wide range of pH values, its action is rapid and generates few reaction by-products if compared to hypochlorite. Experimental studies have highlighted that  $\text{ClO}_2$  shows a good bactericidal activity and it is also active towards viruses. Furthermore, the low concentrations and low contact times required to obtain microbial load reduction are favourable elements for the application of this compound in the industrial sanitizing practices.

**Methods.** As it is impossible to cultivate the Norwalk virus in vitro, we tested the resistance of Feline calicivirus (F9 strain) vs.  $\text{ClO}_2$ , in comparison with HAV (strain HM-175) and CoxsackieB5. Chlorine dioxide was used at concentrations ranging from 0.2 to 0.8 mg/l in water solution, at pH 7 and at +20 °C. Viral suspensions were added

to disinfecting solution and, at pre-set times, were sampled to undergo to titration after blocking the disinfectant action with thiosulphate 0.05 M. On the basis of the data obtained, for each virus and in relation to different concentrations, mean reduction times were calculated for 99%, 99.9% and 99.99% using the regression analysis model.

**Results.** As regards Feline calicivirus, at a concentration of 0.8 mg/l of  $\text{ClO}_2$ , we obtained the complete elimination of the viral titre in 2 min while 30 min were required at concentrations of 0.2 mg/l. Coxsackie B5 showed a similar behaviour, being completely inactivated in 4 min with 0.4 mg/l of  $\text{ClO}_2$  and after 30 min at a concentration of 0.2 mg/l. Inactivation was quicker for HAV, which was eliminated after only 30 sec at a concentration of 0.8 mg/l and after 5 min at 0.4 mg/l.

**Conclusion.** Our data show that for complete inactivation of HAV and Feline calicivirus, concentrations  $\geq 0.6$  mg/l are required. This observation is true for Coxsackie B5 too, but this virus has shown a good sensitivity at all concentration tested according to regression analysis results. For Feline calicivirus and HAV, at low concentrations of disinfectant, prolonged contact times were needed to obtain a 99.99% reduction of viral titres (about 16 and 20 minutes respectively).

## Introduction

Although viruses, unlike bacteria, are incapable for replicating in food, they represent an important cause of foodborne infections.

Viruses with oral-faecal transmission play an important role in the etiological factors involved, and most cases of gastroenteritis are attributed to the Norwalk virus or to the Norwalk-like virus, viruses belonging to the family of caliciviruses, and to the hepatitis A virus.

Food is exposed to risks of primary contamination when the raw materials themselves are contaminated, or secondary contamination when they come into contact with surfaces/equipment which are contaminated [1].

Thus, sanitizing the processing systems and the equipment which comes into contact with the foodstuffs is extremely important in the food industry in order to reduce the risk of secondary contamination, and represents a fundamental instrument to reduce the risk of infection linked to the consumption of foodstuffs.

Hypochlorite and chlorine dioxide ( $\text{ClO}_2$ ) are highly oxidizing and are thus commonly used as disinfectants, especially when disinfecting water.

Studies carried out on potential genotoxic effects of chlorination have shown that the use of sodium hypochlorite leads to the formation of a larger number of mutagen substances than the use of chlorine dioxide [2].

As compared to other oxidizing disinfectants, chlorine dioxide offers certain advantages, such as its efficacy in a wide range of pH values and its rapid action.

If compared to hypochlorite, for instance, it has a higher selectivity and generates a smaller number of reaction products; furthermore, the bactericidal efficacy of  $\text{ClO}_2$  is greater than that of  $\text{HClO}$  since its greater oxidizing capacity has been demonstrated.

Inactivation assays carried out under controlled experimental conditions have shown a different sensitivity towards  $\text{ClO}_2$  on the part of various enteroviruses: at a concentration of 0.32 mg/l in conditions of neutral pH and at a temperature of 15°C, the inactivation time for

Tab. I. Reduction of bacterial load.

Microorganism	Concentration ClO <sub>2</sub> mg/l	Contact Times	% inactivation
<i>Staphylococcus aureus</i>	1.00	60 sec	99.999
<i>Escherichia coli</i>	0.15	300 sec	99.900
<i>Escherichia coli</i>	0.25	60 sec	> 99.999
<i>Streptococcus</i>	1.00	15 sec	> 99.999
<i>Lactobacillus brevis</i>	0.15	5 min	99.900
<i>Lactobacillus brevis</i>	1.00	5 min	> 99.999
<i>Pseudomonas aeruginosa</i>	1.00	60 sec	> 99.999

99.99% was 5 min for *Echo* 7, 3 min for *Coxsackie* B3 and 7 min for the *polio*1 virus [3, 4].

The low concentrations generally required, low contact times and reduced microbial load are favourable elements promoting the use of ClO<sub>2</sub> in the food industry.

Table I illustrates the disinfecting activity of chlorine dioxide [5].

The aim of this study was to assess under experimental conditions the efficacy of chlorine dioxide when used with certain viruses which have proven to be particularly resistant to oxidizing agents, and which has not been thoroughly investigated in the literature.

## Materials and methods

The following were used for the inactivation assays: the feline *Calicivirus* F9 strain grown on CRFK (feline kidney) cultures, the *Coxsackie* B5 virus grown on RC-37 (monkey kidney), and the *Hepatitis A virus* strain HM-175 grown on FRhK4 (monkey kidney embryonic) cultures.

Infected cell cultures were incubated at 37°C until the onset of the cytopathic effect, and subsequently frozen at -80°C to induce cell lysis; the contents of the flask were then submitted to ultra-filtration and re-suspended with sterile physiological solution, and finally aliquoted in sterile test tubes and stored in deepfreeze at -20°C.

The titre of the viral suspension was determined for the hepatitis A virus using the plate method and expressed as PFU, while for the other viruses it was calculated as TCID<sub>50</sub> (titre of the dose infecting 50% of the cell culture) according to the Reed-Muench method; we integrated the titres of 3 or 4 test for each virus and different concentrations.

Chlorine dioxide was used as disinfectant at the following concentrations: 0.2, 0.4, 0.6, 0.8 mg/l.

Viral inactivation assays were carried out at a constant temperature of 20°C with neutral pH kept constant by using a buffer solution at pH 7.

### PERFORMING THE ASSAYS

1 ml of viral suspension was added to the disinfecting solution, then aliquots of samples were collected at pre-set times – T<sub>0</sub>, T<sub>0.5</sub>, T<sub>1</sub>, T<sub>2</sub>, T<sub>3</sub>, T<sub>4</sub>, T<sub>5</sub>, T<sub>15</sub>, T<sub>30</sub>, T<sub>45</sub>, T<sub>60</sub>, – and immediately placed in contact with 0.5 ml

thiosulphate 0.05 M in order to neutralize the disinfectant activity.

For hepatitis A virus, we proceeded by setting up scalar 10-folds dilutions for each contact time and by inoculating them in cell cultures previously grown in 24-wells-plates (0.1 ml/well); the plates were then incubated for 2 hours at 37°C (5% CO<sub>2</sub>). As soon as the contact time has expired, the inoculum was sucked up and a semi-solid medium was added (4% foetal calf serum, 43% MEM 2X, 43% carboxymethylcellulose). After a twelve-days incubation, the cell cultures were fixed with formalin (two hours-contact time), then washed with demineralised water and stained with Giemsa; the following day we washed away the exceeding stain and the cell lysis plaques were counted.

As regards the other viruses assayed, the 10-folds dilutions prepared for each contact time aliquot were placed in 96-wells plates (25 µl/well) previously prepared with 25 µl/well of medium and 50 µl of cell suspension has been added to each well. Finally, after an incubation at 37°C for 4 days, we detected the presence of the cytopathic effect induced by the virus.

## Results

### FELINE CALICIVIRUS

In order to assess the trend of the inactivation assays with *Feline calicivirus*, the logarithms of the titres were calculated and the trends at various concentrations at various times are shown in Figure 1.

At a concentration of 0.8 mg/l the viral titre was eliminated after two minutes, and after thirty minutes at a concentration of 0.2 mg/l.

Mean reduction times were then calculated for 99%, 99.9% and 99.99% inactivation through analysis of regression, giving the results shown in Table II.

Table II shows that at a concentration of 0.8 mg/l a 99.99% reduction was obtained after 2.1 minutes, while 15.5 minutes were required for concentrations of 0.2 mg/l.

### COXSACKIE B5 VIRUS

In this case, logarithms of the titres, as TCID<sub>50</sub>, were calculated too, and results are shown below in Figure 2. It is possible to note that at a concentration of 0.6

**Fig. 1.** Trend of viral titre (log TCID<sub>50</sub>) at different ClO<sub>2</sub> concentration and contact times *Feline calicivirus*.

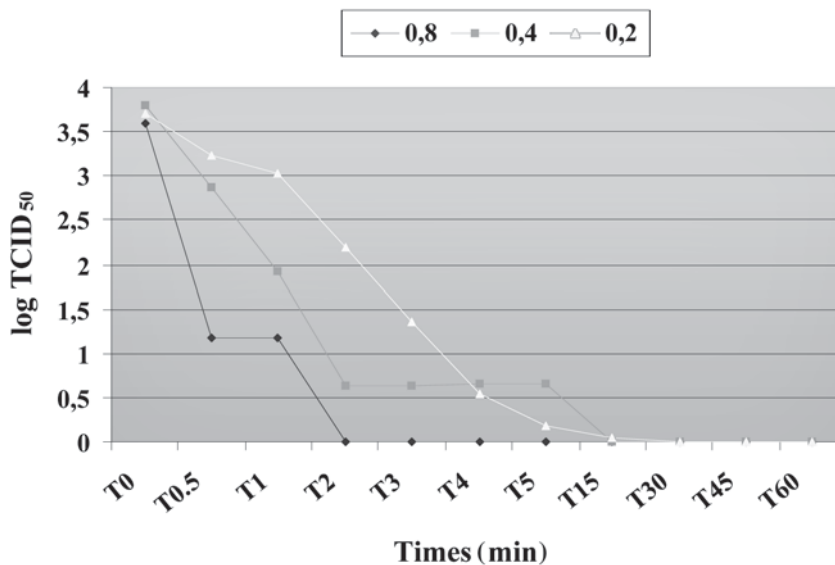

**Tab. II.** Mean reduction times for various inactivation percentages.

<i>ClO<sub>2</sub> – Feline calicivirus – neutral pH</i>			
[ClO <sub>2</sub> ] (mg/l)	Mean time (min) to obtain reduction of:		
	99% (CI 95%)	99.9% (CI 95%)	99.99% (CI 95%)
0.80	0.50 (0.16-0.74)	1.10 (1.05-1.26)	2.10 (2.02-2.22)
0.40	1.24 (0.98-1.52)	3.48 (3.10-3.73)	9.59 (9.16-9.81)
0.20	2.20 (1.80-2.09)	6.20 (5.90-6.90)	15.50 (15.20-15.90)

**Tab. III.** Mean reduction times at various inactivation times.

<i>ClO<sub>2</sub> – Coxsackie Virus B5 – neutral pH</i>			
[ClO <sub>2</sub> ] (mg/l)	Mean time (min) to obtain reduction of:		
	99% (CI 95%)	99.9% (CI 95%)	99.99% (CI 95%)
0.60	0.12 (0.08-0.17)	0.34 (0.27-0.45)	1.00 (0.87-1.15)
0.40	0.57 (0.41-0.79)	1.18 (0.94-1.47)	2.41 (2.20-2.73)
0.20	0.63 (0.45-0.89)	1.52 (1.18-1.95)	3.73 (3.18-4.38)

mg/l the titre was eliminated after 4 minutes, while at a concentration of 0.2 the titre was eliminated after 30 minutes.

By calculating the regression, it was possible to record the mean reduction times at 99%, 99.9% and 99.99%. Results are shown in Table III.

Results show that at concentrations of 0.6 mg/l a 99.99% reduction of the viral titre was obtained after 1 minute, while at a concentration of 0.2 mg/l it was obtained after 3.73 minutes.

**HEPATITIS A VIRUS**

As regards the Hepatitis A virus, the viral titre was calculated according to the PFU method. Figure 3 shows the trends of viral titres at various concentrations

At a concentration of 0.8 mg/l the titre was completely eliminated after only 30 seconds, while at concentrations of 0.4 complete elimination was obtained after 5 minutes.

Finally, mean reduction times for elimination at various percentages were calculated here, too, using the regression analysis as shown in Table IV.

**Considerations and Conclusions**

Chlorine dioxide is an excellent bactericidal agent, as has been reported in various studies, although its virucidal activity has not been thoroughly investigated as yet [6-12].

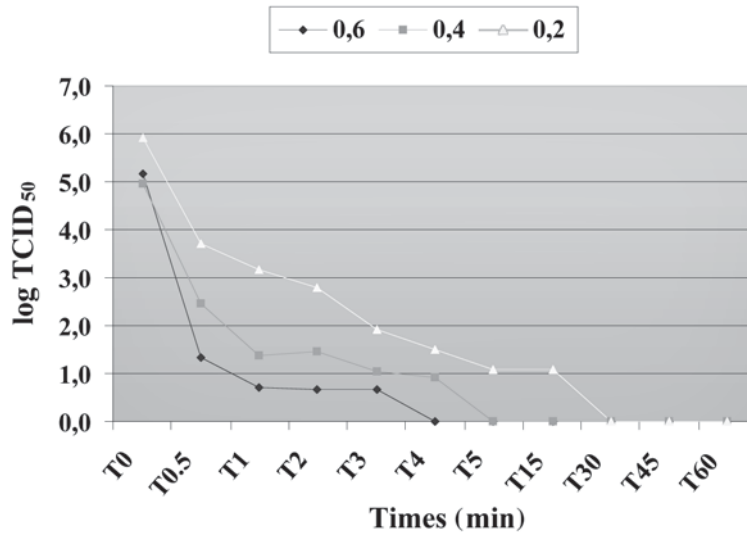
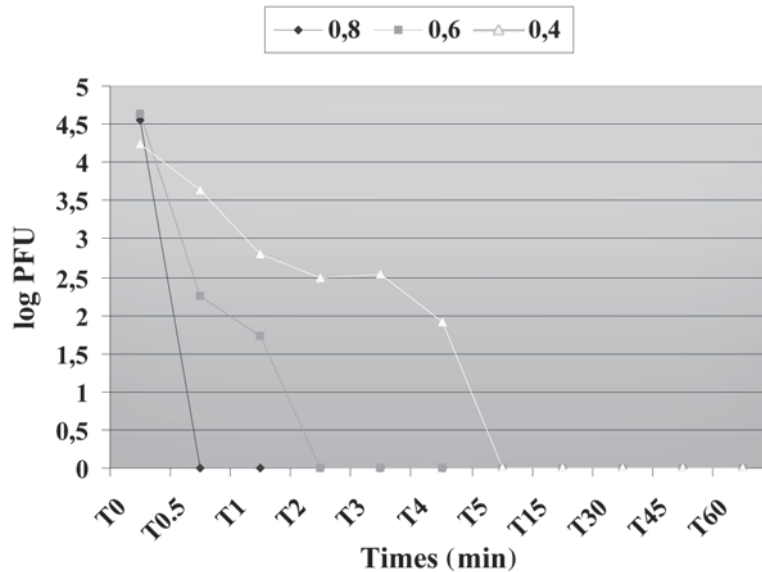

**Fig. 2.** Trend of viral titre (log TCID<sub>50</sub>) at different ClO<sub>2</sub> concentration and contact times Coxsackie B5 virus.**Fig. 3.** Trend of viral titre (log PFU) at different ClO<sub>2</sub> concentration and contact times Hepatitis A virus.

The inactivation kinetics of Poliovirus 1 under experimental conditions have shown that it has a good oxidizing effect [13].

Our results have shown that it is only with concentrations greater than 0.6 mg/l that inactivation is obtained quickly for HAV and for Feline calicivirus, and only Coxsackie B5 shows great sensitivity at all concentrations assayed.

If these data are compared to the inactivation kinetics we performed on Poliovirus 1, the greater resistance

of Calicivirus to Chlorine dioxide is confirmed [14]. This result is particularly important in that it confirms that the Norwalk virus, which the Feline calicivirus is a surrogate of, presents considerable resistance to hypochlorite and is also characterized by strong resistance to Chlorine dioxide. This needs to be taken into account in sanitizing procedures applied to processing systems as well as in direct disinfection treatments of foodstuffs which may be involved as carriers of this virus.

**Tab. IV.** Mean reduction times at various inactivation percentages.

<i>ClO<sub>2</sub> – Hepatitis A virus – neutral pH</i>			
[ClO <sub>2</sub> ] (mg/l)	Mean time (min) to obtain reduction of:		
	99% (CI 95%)	99.9% (CI 95%)	99.99% (CI 95%)
0.80	0.26 *	0.35 *	0.43 *
0.60	0.53 (0.41-0.58)	0.85 (0.76-0.94)	1.45 (1.38-1.53)
0.40	2.35 (1.63-3.40)	6.79 (5.52-8.16)	19.58 (18.70-20.50)

\* It was impossible to calculate confidence limits values because of the very short viral inactivation time.

## References

- [1] Koopmans M, Duizer E. *Food viruses: an emerging problem*. Intern J Food Microbiol 2004;90:23-41.
- [2] Guzzella L, Monarca S, Zani C, Feretti D, Zerbini I, Buschini A, et al. *In vitro potential genotoxic effect of surface drinking water treated with chlorine and alternative disinfectants*. Mutation research 2004;564:179-93.
- [3] Sansebastiano G, Cesari C, Bellelli E. *Further investigation on water disinfection by chlorine dioxide*. Igiene Moderna 1986;85:358-80.
- [4] Sansebastiano G. *Epidemiological review on chlorine dioxide*. In: *Chlorine Dioxide and Disinfection*. Vol. 17. Milano: C.I.P.A. Publisher 1997, p. 63-71.
- [5] Ruzic C. *Chlorine dioxide-based water treatment in the food industry*. In: *Chlorine Dioxide and Disinfection*. Vol. 17. Milano: C.I.P.A. Publisher 1997, p. 197-209.
- [6] Aieta EM, Berg JB. *A review of chlorine dioxide in drinking water treatment*. JAWWA 1986;78:62-72.
- [7] Alvarez ME, O'Brien RT. *Mechanisms of inactivation of poliovirus by chlorine dioxide and iodine*. Appl Environ Microbiol 1982;44:1064-71.
- [8] Bernarde MA, Israel BM, Olivieri VP, Granstrom ML. *Efficiency of chlorine dioxide as a bactericide*. Appl Microbiol 1965;13:776-80.
- [9] Chen YS, Vaughn JM. *Inactivation of human and simian rotaviruses by chlorine dioxide*. Appl Environ Microbiol 1990;56:1363-6.
- [10] Latshaw CL. *Chlorine dioxide: effective broad-spectrum biocide for white-water systems*. Tappi Journal 1994;78:163-6.
- [11] Roller SD. *Some aspects of the mode of action of chlorine dioxide on Bacteria*. Baltimore: M.S. Thesis, Johns Hopkins University 1978.
- [12] Scarpino PV. *Virucidal effectiveness of disinfection processes-chlorine dioxide*. In: *Proceedings of the American Water Works Association, Annual Conference*. 1979, p. 1-35.
- [13] Traenhart O, Kuwert E. *Comparative studies on the action of chlorine and ozone on polioviruses in the reprocessing of drinking water in Essen*. Zbl Bakt I Abt Orig 1975;160:305.
- [14] Sansebastiano G, Mori G, Tanzi ML, Cesari C, Bellelli E. *Chlorine dioxide: methods of analysis and kinetics of inactivation of poliovirus type 1*. Igiene Moderna 1983;79:61-91.

■ Received on June 6, 2006. Accepted on March 28, 2007.

■ Correspondence: Prof G. Sansebastiano, Department of Public Health, Sec. Hygiene, University of Parma, Italy, via Volturmo 39, 43100 Parma, Italy

OFFICE OF NAVAL RESEARCH  
CONTRACT N00014-94-C-0149

TECHNICAL REPORT 97-05

THE EFFECT OF DISINFECTION ON VIABILITY AND FUNCTION OF BABOON  
RED BLOOD CELLS AND PLATELETS

BY

C.R. VALERI, G. RAGNO, H. MACGREGOR, AND L.E. PIVACEK

NAVAL BLOOD RESEARCH LABORATORY  
BOSTON UNIVERSITY SCHOOL OF MEDICINE  
615 ALBANY STREET  
BOSTON, MA 02118

11 JULY 1997

Reproduction in whole or in part is permitted for any purpose of  
the United States Government.

Distribution of this report is unlimited.

19990225156

THE EFFECT OF DISINFECTION ON VIABILITY AND FUNCTION OF  
BABOON RED BLOOD CELLS AND PLATELETS

C. R. VALERI, G. RAGNO, H. MACGREGOR, L.E. PIVACEK

**ABSTRACT:** Blood disinfection is currently being evaluated as a means of reducing or eliminating the risks of disease transmission associated with blood transfusion. For the past 10 years our laboratory has used baboons to evaluate the effects of various disinfection treatments on autologous red blood cell and platelet viability and function in vitro and in vivo. We have used radioactive ( $^{51}\text{Cr}$ ) methods to evaluate the posttransfusion survival and lifespan of disinfected red blood cells. The in vivo recovery and lifespan of platelets were assessed using either radioactive  $^{51}\text{Cr}$  or  $^{111}\text{In}$ . The function of the platelets was evaluated by their ability to correct an aspirin-induced thrombocytopeny. We observed that in some instances in which the disinfected autologous red blood cells showed no alterations in vitro measurement, recovery in vivo and lifespan were decreased. In view of these findings, we believe that it is prudent to continue studies in the baboon before attempting studies in normal volunteers.

**INTRODUCTION:** For the past 20 years, our laboratory has used the baboon (*Papio sp.*) to evaluate the effects of methods to preserve red blood cells and platelets. We have

been using the baboon in studies to evaluate whether blood disinfection adversely affects red blood cells. When in vitro measurements indicate that a disinfection treatment does not significantly damage the baboon red blood cells, in vivo studies are performed to assess the effect of disinfection of autologous baboon red blood cells on 24-hour posttransfusion survival and lifespan.

Disinfected platelets also can be assessed in the baboon. The posttransfusion survival, lifespan and function of disinfected platelets can be studied in baboons subjected to an aspirin-induced thrombocytopathy, an approach that has been used in studies at the Naval Blood Research Laboratory for more than 20 years in normal volunteers and for more than 10 years in baboons.<sup>1-3</sup>

Our laboratory also has used the baboon to study the effects of hypothermia on hemostasis before we conducted the experiments in normal volunteers and patients.<sup>4-10</sup> We have found that data obtained from baboon studies are similar to those seen in studies of normal volunteers and believe that human studies can be reduced by using the baboon in specific areas of research. The following experiments were performed to evaluate the effects of various disinfection treatments on the survival and function of red blood cells and platelets.

## METHODS

### A. Disinfected Red Blood Cells:

1. In Vitro Measurements: To determine whether red blood cells are damaged by a particular disinfection treatment, the following measurements were made: hematocrit, hemoglobin, red blood cell count, mean corpuscular volume, mean corpuscular hemoglobin, and mean corpuscular hemoglobin concentration measured using an electronic particle counter; plasma hemoglobin measured using a dual-beam spectrophotometer;<sup>11</sup> intracellular and extracellular sodium and potassium measured using a flame photometer;<sup>12</sup> and adenosine triphosphate (ATP) measured using a fluorometer.<sup>13</sup> The function of the red blood cells was evaluated by their ability to transport oxygen as assessed by measurement of 2,3 diphosphoglycerate (DPG)<sup>14</sup> and red blood cell p50,<sup>15</sup> the partial pressure at which 50% of the hemoglobin is saturated with oxygen.

2. In Vivo Measurements: The 24-hour posttransfusion survival and lifespan were measured in baboons and normal volunteers using a double-label isotope procedure. The baboon's blood volume was measured using 125-Iodinated human serum albumin, and the 24-hour posttransfusion survival and lifespan of the disinfected autologous red blood cells were measured using 51-Cr disodium chromate.<sup>16-19</sup>

3. Disinfection Treatments: The following disinfection treatments were evaluated:

a. **Benzoporphyrin derivative (BPD) and photoactivation:**--Blood was collected into the CPD-ADSOL blood collection system, and red blood cells were prepared with a final hematocrit of 55 V%. BPD was added to the red blood cells to achieve a final concentration of 0.5  $\mu\text{g}/\text{ml}$ ; the red blood cells were stored at room temperature for 60 minutes and then washed 3 times with phosphate buffered saline (PBS). The red blood cells were then exposed to photoactivation to achieve a total fluence of 6.5  $\text{J}/\text{cm}^2$ , washed once with a solution referred to as American Red Cross Solution 8 (ARC8), resuspended in the ARC8 solution to achieve a final hematocrit of 55 V%, and stored at 4 C for 24 hours prior to in vitro and in vivo evaluation.

a1. **Control:** Blood was collected into the CPD-ADSOL blood collection system but the BPD solution was not added and photoactivation was not employed. Storage and washing procedures were the same as those for the treated red blood cells.

b. **Panaviroicide**--Two different formulations of Panaviroicide, a solution containing glutaraldehyde and detergents, were evaluated. Solutions 1 and 2 contained the same amount of glutaraldehyde; however, solution 2 contained significantly less detergent.

Blood collected into CPD anticoagulant was treated by adding Panaviroicide solution to achieve a final concentration of 10% Panaviroicide solution in blood. The Panaviroicide was allowed to remain with the blood for 60

minutes at room temperature, and the blood was washed with PBS.

b1. **Control:** Blood collected into CPD anticoagulant was treated as described above except PBS solution was added to the blood in place of the Panavirocide solution.

c. **Aluminum phthalocyanines and photoactivation**<sup>20-22</sup>--Eighty-five (85) ml of baboon blood were collected into CPD anticoagulant. The blood was centrifuged to prepare a red blood cell concentrate, and the red blood cells were treated with 10 uM aluminum phthalocyanine and 44 J/cm<sup>2</sup> visible light. The treated red blood cells were washed with PBS prior to evaluation.

c1. **Control:** Baboon blood was collected into CPD anticoagulant and red blood cells prepared as above. The red blood cells were not treated with phthalocyanine or light, but were washed as above.

d. **Formaldehyde**<sup>23-25</sup>--Seventy-five (75) ml of blood were collected into 10.5 ml of CPD anticoagulant in a 300 ml polyvinylchloride (PVC) transfer pack. The blood was placed on an Eberbach shaker set at low speed (180 lateral oscillations per minute) and the formaldehyde solution was added to the blood over a 1-2 minute period to achieve a final concentration of 250 ppm. The formaldehyde-treated blood was stored at 4 C for 24 hours and an aliquot was removed for evaluation.



d1) **Control:** Instead of the formaldehyde solution, a similar volume of sodium chloride solution was added to the CPD-collected blood and the treated blood was stored at 4 C for 24 hours.

e. **Sodium chlorite<sup>26</sup>**--Blood collected into citrate-phosphate-dextrose (CPD) anticoagulant was treated with sodium chlorite solution. Sodium chlorite activated with a CPD solution was added to whole blood to achieve a final concentration of 0.75 to 15 mM. The blood was not washed following disinfection.

e1. **Control:** Sodium chlorite was added to a sodium chloride solution to prepare a "non-activated" form of the disinfectant. The non-activated sodium chloride disinfectant was added to the whole blood to achieve the same final concentration as the activated sodium chlorite disinfectant.

#### Disinfectant Effectiveness and Viability

We did not evaluate the disinfectant treatments for virucidal and/or bacterial killing. The doses and protocols required for disinfection with each method were provided either by the company or by persons supplying the disinfectant. Neither did we evaluate the toxicity of the disinfectant treatments.

**B. Disinfected Platelets:**

1. In Vitro Measurements: Both baboon and human platelets have been assessed in vitro by their ability to aggregate to arachidonic acid (AA) and adenosine diphosphate (ADP), ability to produce thromboxane A<sub>2</sub> during aggregation to AA and ADP, response to hypotonic stress, and measurements of pH, pO<sub>2</sub> and pCO<sub>2</sub>.<sup>27</sup>

2. In Vivo Measurements: Platelet survival in vivo has been measured in both humans and baboons using the double-label isotope procedure used to measure red blood cell survival in vivo.<sup>28,29</sup> Blood volume was measured using either 51-Cr labeled autologous fresh red blood cells or 125-Iodinated human serum albumin; platelet survival was measured using either 51-Cr labeled or 111-Indium-oxine labeled autologous platelets. Posttransfusion survival and lifespan have been measured in baboon platelets preserved using both liquid and frozen procedures.<sup>29</sup>

The ability of preserved platelets to function in vivo has been assessed by producing an aspirin-induced thrombocytopathy in the baboon. The administration of 325 mg of aspirin into the baboon produced a prolonged bleeding time measured using a standard template (Simplat) method. Blood collected from the bleeding time site (referred to as "shed blood") had a significantly reduced thromboxane A<sub>2</sub> level. The ability of the preserved or treated platelets to increase the shed blood thromboxane A<sub>2</sub> level and reduce the

extended bleeding time is the measure of their function in vivo.

**Statistical Analyses:** Non-paired and paired t-tests were used to test the significance of the effects of \_\_\_\_\_ disinfection; a p value of 0.05 was considered significant.

## RESULTS

### A. Red Blood Cells

#### 1. Comparison of Human and Baboon Blood Prior to and Following Disinfection

Tables 1 and 2 report the in vitro effects of disinfecting human and baboon blood using two of the disinfection methods described above (Panavirocide and BPD/Photoactivation). These data demonstrate that both disinfection methods resulted in a significant reduction in intracellular potassium in both baboon and human blood.

When human blood was treated with Panavirocide Solution, Formulation 1, the intracellular potassium level decreased significantly from 7.1 to 0.7 mEq/ $10^{12}$  RBC, the plasma hemoglobin increased from 15 mg/dl to 308 mg/dl, and the percent hemolysis increased from 0.08 to 0.60%. Baboon blood treated with Panavirocide Solution, Formulation 1, showed results similar to those observed with human blood with the exception that following treatment, the increase in plasma hemoglobin was not as great in baboon blood as that seen with human blood. Treatment of baboon blood with Panavirocide Solution, Formulation 2, resulted in increased plasma hemoglobin and intracellular potassium levels (Table 1).

Treatment of human and baboon blood with benzoporphyrin derivative and photoactivation resulted in a decrease in

intracellular potassium and increases in plasma hemoglobin and percent hemolysis. Red blood cell ATP was slightly increased in both the human and baboon blood following treatment. This increase was due to the post-treatment storage of the red blood cells in the ARC8 resuspension media and was not a result of the BPD/photoactivation treatment. Red blood cell 2,3 DPG and P50 were unaffected by the treatment (TABLE 2)

## 2. Disinfection Treatments

Tables 3 and 4 report the 24-hour posttransfusion survival and lifespan of baboon red blood cells after treatment with the five disinfection treatments described above. Baboon red blood cells treated with Panavirocide solution, Formulation 1, had a 24-hour posttransfusion survival value of 0% and those treated with BPD and photoactivation had a value of 22%. These values are significantly ( $p < 0.001$ ) lower than the 85-90% 24-hour posttransfusion survival values seen in the control studies.

In the study using the non-activated sodium chlorite, which was performed as a control for the activated sodium chlorite studies, there was actually more damage to the red blood cells at the 15 mM concentration. The 24-hour posttransfusion survival value was 75% for the red blood cells in the control studies and 87% for the red blood cells treated with activated sodium chlorite.

These data demonstrate significant reductions in the 24 hour posttransfusion survival of the baboon red blood cells treated with Panavirocide solution #1, BPD/photoactivation and 15 mM of non-activated sodium chlorite. Treatment with Panavirocide solution #2, 250 ppm formaldehyde, phthalocyanines and photoactivation, or activated sodium chlorite produced no significant effect on the 24-hour posttransfusion survival values.

Table 4 reports that red blood cells treated with Panavirocide solution #2, BPD and photoactivation or 15 mM of non-activated sodium chlorite had a significantly shorter lifespan than did the control values.

#### B. Platelets

Ingestion of 325 mg of aspirin to produce an aspirin-induced thrombocytopathy in baboons increases bleeding time from 3 to 5 minutes. Associated with the increased bleeding time is a decrease in shed blood thromboxane A<sub>2</sub> from about 1500 pg/0.1 ml to 200 pg/0.1 ml. Results in baboon studies have been found to be similar to those obtained in studies in normal volunteers<sup>2,3</sup> and patients<sup>10</sup> treated with aspirin. Baboons transfused 1 unit of platelets stored at 22 C for 18 hours or 2 units of previously frozen platelets exhibit a significant reduction in bleeding time and an increase in shed blood thromboxane A<sub>2</sub>. No such decrease in bleeding time or increase in shed blood thromboxane A<sub>2</sub> level was seen in baboons transfused 2 units of platelets stored at 22 C

for 5 days (unpublished data). In vivo recovery and lifespan values following the transfusion of fresh or preserved platelets were similar in baboons and normal volunteers.

**DISCUSSION**

Baboon red blood cells exposed to different disinfectant treatments responded in a manner similar to that observed of human red blood cells. Red blood cell damage related to the disinfection treatment was reflected in a decreased intracellular potassium level and reduced 24-hour posttransfusion survival value. Intracellular potassium levels correlated with 24-hour posttransfusion survivals: when these levels were decreased, as with the Panavirocide solution Formulation 1 and BPD/photoactivation treatment, the 24-hour posttransfusion survival was reduced. However, red blood cells with reduced lifespan values did not necessarily have reduced 24-hour posttransfusion survival values, as in the case of the blood treated with Panavirocide Solution Formulation 2. This indicates that the damage to the red blood cells, assessed by the 24-hour value, was not caused by the treatment, but rather that the treatment resulted in a change in red blood cell antigenicity, assessed by the lifespan  $T_{1/2}$  value

Other investigators have reported a correlation between red blood cell ATP and 24-hour posttransfusion survival. However, in our study, we observed a significant reduction in intracellular potassium for red blood cells treated with BPD and photoactivation associated with an increase in red blood cell ATP. The significant reduction in the 24-hour posttransfusion survival of these red blood cells suggests that the intracellular potassium level may be a more



important in vitro predictor of the 24-hour posttransfusion survival than the red blood cell ATP level.

These data demonstrate that the baboon can be used to study the in vitro and in vivo effects of a variety of treatments, including red blood cell and platelet disinfection.

**ACKNOWLEDGEMENTS**

Sodium chlorite solution provided by Mr. David Scheer,  
Alcide Corporation.

Benzoporphyrin derivative (BPD) provided by Quadra Logic  
Technologies, Baxter Corp., and American Red Cross,  
Bethesda, MD

Panavirocide provided by Mr. Yash Sharma, Medicine and  
Applied Sciences Institute, Inc.

Aluminum phthalocyanine provided by Drs. Bernard Horowitz  
and Ehud Ben-Hur, New York Blood Center.

Formaldehyde solution provided by Dr. Allan Louderback,  
Clinical Chemistry Consultants

The authors also acknowledge the editorial assistance  
of Ms. Cynthia A. Valeri and the secretarial assistance of  
Ms. Marilyn Leavy.

## REFERENCES

1. Handin, R.I. and C.R. Valeri (1971) Hemostatic effectiveness of platelets stored at 22 C. *NEJM* 285, 538-543.
2. Valeri, C.R. (1974) Hemostatic effectiveness of liquid-preserved and previously frozen platelets. *NEJM* 290, 353-358.
3. Valeri, C.R. (1976) Circulation and hemostatic effectiveness of platelets stored at 4 C or 22 C: Studies in aspirin-treated normal volunteers. *Transfusion* 16, 20-23.
4. Valeri, C.R., H. Feingold, G.P. Cassidy, G. Ragno, S.F. Khuri and M.D. Altschule (1987) Hypothermia induced-reversible platelet dysfunction. *Ann Surg* 205, 175-181.
5. Valeri, C.R., H. MacGregor, F. Pompei and S.F. Khuri (1991) Acquired abnormalities of platelet function. *N Engl J Med* 324, 1670.
6. Valeri, C.R., H. MacGregor, G. Cassidy, R. Tinney and F. Pompei (1995) Effects of temperature on bleeding time and clotting time in normal male and female volunteers. *Crit Care Med* 23, 698-704.
7. Michelson, A.D., H. MacGregor, M.R. Barnard, A.S. Kestin, M.J Rohrer and C.R. Valeri (1994). Reversible inhibition of platelet activation by hypothermia in vivo and in vitro. *J Thromb Haemost* 5, 633-640.
8. Khuri, S.F., A.D. Michelson and C. R. Valeri (1994) The effect of cardiopulmonary bypass on hemostasis and coagulation. In *Thrombosis and Hemorrhage* (Edited by J. Loscalzo and A.I. Schafer), pp 1051-1073, Blackwell Scientific, Cambridge.
9. Khuri, S.F., J.A. Wolfe, M. Josa, T. C. Axford, I. Szymanski, S.N. Assousa, G. Ragno, M. Patel, A. Silverman, M. Park and C.R. Valeri (1992) Hematologic changes during and after cardiopulmonary bypass and their relationship to bleeding time and non-surgical blood loss. *J Thorac Cardiovasc Surg* 104, 94-107.
10. Valeri, C.R., K.R. Khabbaz, S.F. Khuri, C. Marquardt, G. Ragno, H. Feingold, A.D. Gray and T. Axford (1992) Effect of skin temperature on platelet function in patients undergoing extracorporeal bypass. *J Thorac Cardiovasc Surg* 104, 108-116.

11. Blakney, G.B. and A.J. Dinwoodie (1975) A spectrophotometric scanning technique for the rapid determination of plasma hemoglobin. Clin Biochem 8, 96-102.
12. Runck, A., C.R. Valeri and W. Sampson (1968) Comparison of effects of ionic and non-ionic solutions on volume and intracellular potassium of frozen and non-frozen human red cells. Transfusion 8, 9-18.
13. Lamprecht, W. and I. Trautschold (1963) Determination with hexokinase and glucose-6-phosphate dehydrogenase. In Methods of Enzymatic Analysis (Edited by H.U. Bergmeyer) pp. 543-558, New York: Academic Press.
14. Keitt, A.S. (1966) Pyruvate kinase deficiency and related disorders of red cell glycolysis. Am J Med 41, 762-785.
15. Asakura, T. and M.P. Reilly (1984) Methods for the measurement of oxygen equilibrium curves of red cell suspensions and hemoglobin solutions. In Oxygen Transport in Red Blood Cells (Edited by C. Nicolau), pp 57-75, Proc. of the 12th Aharon Katzir Katchlasky Conference, Tours, France, 4-7 April.
16. Valeri, C.R., J.R. Lindberg, T.J. Contreras, L.E. Pivacek, R.M. Austin, D.A. Valeri, A. Gray and C.P. Emerson (1981) Measurement of red blood cell volume, plasma volume, and total blood volume in baboons. Am J Vet Res 42, 1025-1029.
17. Valeri, C.R., J.R. Lindberg, T.J. Contreras, L.E. Pivacek, R.M. Austin, D.A. Valeri, A. Gray and C.P. Emerson (1981) Liquid preservation of baboon red blood cells in acid-citrate-dextrose or citrate-phosphate-dextrose anticoagulant: Effects of washing liquid stored red blood cells. Am J Vet Res 42, 1011-1013.
18. Valeri, C.R., J.R. Lindberg, T.J. Contreras, G.B. Lowrie, L.E. Pivacek, A. Gray, D.A. Valeri and C.P. Emerson (1981) Freeze-preserved baboon red blood cells: Effect of biochemical modification and perfusion in vitro. Am J Vet Res 42, 1590-1594.
19. Valeri, C.R. (1971) Viability and function of preserved red cells. NEJM 284, 81-88.
20. Horowitz, B., S. Rywkin, H. Margolis-Nunno, B. Williams, N. Geacintov, A.M. Prince, D. Pascual, G. Ragno, C.R. Valeri and T. Huima-Byron (1992) Inactivation of viruses in red cell and platelet concentrates with aluminum phthalocyanine (AlPc) sulfonates. Blood Cells 18, 141-150.

21. Margolis-Nunno, H., A. Bartley, E. Ben-Hur, T. Huima-Byron, H. MacGregor, R. Robinson, C.R. Valeri and B. Horowitz (1993) Quencher mediated protection of platelet integrity during psoralen photoinactivation of viruses in platelet concentrates. *Blood* 82(10), 401a.
22. Rywkin, S., E. Ben-Hur, D. Pascual, A.M. Prince, M. Reid, M. Kenney, N.L. Oleinick, J.E. van Lier and B. Horowitz (1993) New photosensitizers to inactivate viruses in red blood cells. *Blood* 82(10), 205a.
23. Council on Scientific Affairs (1989) Council report: Formaldehyde. *JAMA* 261, 1183-1187.
24. Louderback, A.L. (1989) Method of inactivating HTLV-III virus in blood. Patent #3,833,165. 23 May.
25. Louderback, A. (1992) Sterilization of red blood cells. AABB Annual Meeting, San Francisco, CA November.
26. Sarin, P.S., D.I. Scheer and R.D. Kross (1985) Inactivation of human T- cell lymphotropic retrovirus (HTLV-III) by LDtm. *N Engl J Med* 313, 1416.
27. Feingold, H.M., L.E. Pivacek, A.J. Melaragno and C.R. Valeri (1986) Coagulation assays and platelet aggregation patterns in human, baboon and canine blood. *Am J Vet Res* 47, 2197-2199.
28. Valeri, C.R., H. Feingold and L.D. Marchionni (1974) The relation between response to hypotonic stress and the <sup>51</sup>Cr recovery in vivo of preserved platelets. *Transfusion* 14, 331-337.
29. Melaragno, A.J., W. Abdu, R. Katchis, A. Doty and C.R. Valeri (1981) Liquid and freeze preservation of baboon platelets. *Cryobiology* 18, 445-452.

TABLE 1

## RED BLOOD CELL DISINFECTION USING PANAVIROCIDIC SOLUTION

	RED CELL RECOVERY (%)	INTRA K <sup>+</sup> (mEq/10 <sup>12</sup> RBC)	PLASMA HGB (mg/dl)	HEMOLYSIS (%)
<u>Human Blood</u>				
Pre-Treatment				
X:	---	7.1	15	0.08
SD:		1.1	10	0.03
N:		3	3	2
Post-Treatment Formulation 1				
X:	98	0.7	308	0.60
SD:	1	0.2	237	0.30
N:	2	3	3	2
p value:		<.001	NS	NS
<u>Baboon Blood</u>				
Pre-Treatment				
X:	--	7.4	13	0.07
SD:		0.6	9	0.04
N:		4	4	4
Post-Treatment Formulation 1				
X:	98	1.6	98	0.31
SD:	3	0.6	54	0.04
N:	3	4	4	4
p value:		<.001	<.05	<.001
Post-Treatment Formulation 2				
X:	--	8.6	315	---
SD:		0.4	30	
N:		7	7	
p value:		<.01	<.001	

TABLE 2

RED BLOOD CELL DISINFECTION TREATMENT USING BENZOPORPHYRIN DERIVATIVE (BPD) AND PHOTOACTIVATION

RED CELL RECOVERY (%)	INTRA K+ (mEq/10 <sup>12</sup> RBC)	PLASMA HGB (mg/dl)	HEMOLYSIS (%)	ATP (um/gHb)	2,3DPG	P50 (mmHg)
-----------------------	-------------------------------------	--------------------	---------------	--------------	--------	------------

Human Blood

Pre-Treatment

X:	--	8.7	39	0.11	3.7	11.0	32.7
SD:		0.7	6	0.01	0.2	1.6	3.0
N:		3	3	3	3	3	3

Post-Treatment with 0.5 ug/ml BPD

X:	96.1	4.0	131	0.33	5.7	11.0	31.9
SD:	0.8	0.9	47	0.12	0.3	1.2	0.7
N:	3	5	5	5	3	3	3

p value: <.001 <.05 <.05 <.05 <.001 NS NS

Baboon Blood

Pre-Treatment

X:	--	8.7	31	0.08	2.9	9.1	32.2
SD:		0.8	6	0.01	0.6	1.8	0.0
N:		3	3	3	3	3	3

Post-Treatment with 0.5 ug/ml BPD

X:	95.8	3.7	167	0.41	5.0	9.4	32.3
SD:	4.1	1.3	91	0.19	0.4	0.7	1.0
N:	3	5	5	5	3	3	2

p value: <.001 <.05 <.05 <.05 <.001 NS NS

TABLE 3

EFFECT OF DISINFECTION TREATMENT ON IN VIVO 24-HOUR POSTTRANSFUSION SURVIVAL OF RED BLOOD CELLS IN BABOONS

	BPD/Photo- activation	Panavirocide Soln #1	Soln #2	Formaldehyde (250 ppm)	Phthalocyanine/ photoactivation	Sodium Chlorite 0.75 mM	Sodium Chlorite 15 mM
TREATED							
MEAN:	22	0	89	90	92	87	87
SD:	10	0	5	5	--	3	2
N:	2	3	7	8	2	2	2
CONTROL							
MEAN:	89	88	--	88	93	87	75
SD:	2	3	--	5	--	2	5
N:	3	3		4	2	2	8
Non-paired t-test	<.001	<.001	NS	NS	NS	NS	<.01
p value:							



TABLE 4

EFFECT OF DISINFECTANT TREATMENT ON IN VIVO RED BLOOD CELL LIFESPAN IN BABOONS

BPD/Photo-activation	Panaviricide soln #1	Soln #2	Formaldehyde (250 ppm)	Phthalocyanine/ photoactivation	Sodium Chlorite 0.75 mM	Sodium Chlorite 15 mM
----------------------	----------------------	---------	------------------------	---------------------------------	-------------------------	-----------------------

TREATED

MEAN:	7.7	11.6	14.9	13.2	14.0	13.0
SD:	1.7	1.7	3.2	---	1.0	1.0
N:	2	7	8	2	2	2

CONTROL

MEAN:	13.5	15.2	13.6	14.1	13.0	10.0
SD:	2.5	2.3	0.9	---	1.0	1.0
N:	3	3	4	2	2	8

Non-paired t-test  
p value: <.001

<.001

NS

NS

<.01



EPA/635/R-00/007

**TOXICOLOGICAL REVIEW**

**OF**

**CHLORINE DIOXIDE**

**AND**

**CHLORITE**

(CAS Nos. 10049-04-4 and 7758-19-2)

**In Support of Summary Information on the  
Integrated Risk Information System (IRIS)**

*September 2000*

U.S. Environmental Protection Agency  
Washington, DC

## **DISCLAIMER**

This document has been reviewed in accordance with U.S. Environmental Protection Agency policy. Mention of trade names or commercial products does not constitute endorsement or recommendation for use.

This document may undergo revisions in the future. The most up-to-date version will be made electronically via the IRIS Home Page at <http://www.epa.gov/iris>.

# CONTENTS

FOREWORD .....	v
AUTHORS, CONTRIBUTORS, AND REVIEWERS .....	vi
1. INTRODUCTION .....	1
2. CHEMICAL AND PHYSICAL INFORMATION RELEVANT TO ASSESSMENTS .....	2
3. TOXICOKINETICS RELEVANT TO ASSESSMENTS .....	3
3.1. ABSORPTION .....	3
3.1.1. Gastrointestinal Absorption .....	3
3.1.2. Respiratory Tract Absorption .....	4
3.1.3. Dermal Absorption .....	4
3.2. DISTRIBUTION .....	4
3.2.1. Chlorine Dioxide .....	4
3.2.2. Chlorite .....	4
3.3. METABOLISM .....	5
3.3.1. Chlorine Dioxide .....	5
3.3.2. Chlorite .....	5
3.4. ELIMINATION .....	5
3.4.1. Chlorine Dioxide .....	5
3.4.2. Chlorite .....	5
4. HAZARD IDENTIFICATION .....	6
4.1. STUDIES IN HUMANS—EPIDEMIOLOGY, CASE REPORTS, CLINICAL CONTROLS .....	6
4.1.1. Oral Exposure .....	6
4.1.2. Inhalation Exposure .....	9
4.2. PRECHRONIC AND CHRONIC STUDIES AND CANCER BIOASSAYS IN ANIMALS—ORAL AND INHALATION .....	10
4.2.1. Oral Exposure .....	10
4.2.2. Inhalation Exposure .....	16
4.3. REPRODUCTIVE/DEVELOPMENTAL STUDIES—ORAL AND INHALATION .....	18
4.3.1. Chlorine Dioxide .....	18
4.3.2. Chlorite .....	20
4.4. OTHER STUDIES .....	26

**CONTENTS (continued)**

- 4.4.1. Other Carcinogenicity Studies . . . . . 26
- 4.4.2. Genotoxicity Studies . . . . . 27
- 4.4.3. Mechanistic Studies . . . . . 28
- 4.5. SYNTHESIS AND EVALUATION OF MAJOR NONCANCER EFFECTS AND  
MODE OF ACTION (IF KNOWN)—ORAL AND INHALATION . . . . . 28
  - 4.5.1. Oral Exposure . . . . . 28
  - 4.5.2. Inhalation Exposure . . . . . 30
- 4.6. WEIGHT-OF-EVIDENCE EVALUATION AND CANCER  
CHARACTERIZATION—SYNTHESIS OF HUMAN, ANIMAL, AND OTHER  
SUPPORTING EVIDENCE, CONCLUSIONS ABOUT HUMAN  
CARCINOGENICITY, AND LIKELY MODE OF ACTION . . . . . 31
  - 4.6.1. Chlorine Dioxide . . . . . 31
  - 4.6.2. Chlorite . . . . . 31
- 4.7. SUSCEPTIBLE POPULATIONS . . . . . 32
  - 4.7.1. Possible Childhood Susceptibility . . . . . 32
  - 4.7.2. Possible Gender Differences . . . . . 32
- 5. DOSE-RESPONSE ASSESSMENTS . . . . . 33
  - 5.1. ORAL REFERENCE DOSE (RfD) . . . . . 33
    - 5.1.1. Choice of Principal Study and Critical Effect—With Rationale  
and Justification . . . . . 33
    - 5.1.2. Methods of Analysis—Including Models (PBPK, BMD, etc.) . . . . . 34
    - 5.1.3. RfD Derivation—Including Application of Uncertainty Factors and Modifying  
Factors . . . . . 35
  - 5.2. INHALATION REFERENCE CONCENTRATION (RfC) . . . . . 35
    - 5.2.1. Choice of Principal Study and Critical Effect—With Rationale  
and Justification . . . . . 35
    - 5.2.2. Methods of Analysis—NOAEL/LOAEL . . . . . 36
    - 5.2.3. RfC Derivation—Including Application of Uncertainty Factors and  
Modifying Factors . . . . . 37
  - 5.3. CANCER ASSESSMENT . . . . . 38
    - 5.3.1. Chlorine Dioxide . . . . . 38
    - 5.3.2. Chlorite . . . . . 38
- 6. MAJOR CONCLUSIONS IN THE CHARACTERIZATION OF HAZARD  
AND DOSE RESPONSE . . . . . 38
  - 6.1. HUMAN HAZARD POTENTIAL . . . . . 38
  - 6.2. DOSE RESPONSE . . . . . 40
- 7. REFERENCES . . . . . 40
- APPENDIX A. EXTERNAL PEER REVIEW—SUMMARY OF COMMENTS AND  
DISPOSITION . . . . . 46

## **FOREWORD**

The purpose of this Toxicological Review is to provide scientific support and rationale for the hazard and dose-response assessment in IRIS pertaining to chronic exposure to chlorine dioxide and chlorite. It is not intended to be a comprehensive treatise on the chemical or toxicological nature of chlorine dioxide and chlorite.

In Section 6, EPA has characterized its overall confidence in the quantitative and qualitative aspects of hazard and dose response. Matters considered in this characterization include knowledge gaps, uncertainties, quality of data, and scientific controversies. This characterization is presented in an effort to make apparent the limitations of the assessment and to aid and guide the risk assessor in the ensuing steps of the risk assessment process.

For other general information about this assessment or other questions relating to IRIS, the reader is referred to EPA's Risk Information Hotline at 513-569-7254.

## **AUTHORS, CONTRIBUTORS, AND REVIEWERS**

### **Chemical Managers/Authors**

Yogendra Patel, Ph.D.  
OST/HECD  
Office of Water  
U.S. Environmental Protection Agency  
Washington, DC

Diana Wong, Ph.D., D.A.B.T.  
OST/HECD  
Office of Water  
U.S. Environmental Protection Agency  
Washington, DC

### **Contributing Authors**

Lisa Ingerman, Ph.D., D.A.B.T.  
Senior Scientist  
Syracuse Research Corporation  
Portland, OR

Patricia McGinnis, Ph.D., D.A.B.T.  
Senior Scientist  
Syracuse Research Corporation  
Philadelphia, PA

Mark Osier, Ph.D.  
Senior Scientist  
Syracuse Research Corporation  
North Syracuse, NY

### **Reviewers**

This document and summary information on IRIS have received peer review both by EPA scientists and by independent scientists external to EPA. Subsequent to external review and incorporation of comments, this assessment has undergone an Agencywide review process whereby the IRIS Program Manager has achieved a consensus approval among the Office of Research and Development; Office of Air and Radiation; Office of Prevention, Pesticides, and Toxic Substances; Office of Solid Waste and Emergency Response; Office of Water; Office of Policy, Planning, and Evaluation; and the Regional Offices.

## **AUTHORS, CONTRIBUTORS, AND REVIEWERS (continued)**

### **Internal EPA Reviewers**

Annie J. Jarabek  
ORD / NCEA  
Research Triangle Park, NC

Ginger Moser, Ph.D., D.A.B.T.  
ORD / NTD/NHEERL  
Research Triangle Park, NC

### **External Peer Reviewers**

Paul E. Brubaker, Ph.D.  
Consultant  
Brubaker and Associates

James Edward Klaunig, Ph.D.  
Division of Toxicology, Department of Pharmacology and Toxicology  
Indiana University School of Medicine

June Dunnick, Ph.D.  
Scientist  
National Institute of Environmental Health Sciences

Calvin C. Willhite, Ph.D.  
State of California, Department of Toxic Substances Control

Summaries of the external peer reviewers' comments and the disposition of their recommendations are in the Appendix.



## 1. INTRODUCTION

This document presents background and justification for the hazard and dose-response assessment summaries in the U.S. Environmental Protection Agency (EPA) Integrated Risk Information System (IRIS). IRIS summaries may include an oral reference dose (RfD), inhalation reference concentration (RfC), and a carcinogenicity assessment.

The RfD and RfC provide quantitative information for noncancer dose-response assessments. The RfD is based on the assumption that thresholds exist for certain toxic effects such as cellular necrosis but may not exist for other toxic effects such as some carcinogenic responses. It is expressed in units of mg/kg-day. In general, the RfD is an estimate (with uncertainty spanning perhaps an order of magnitude) of a daily exposure to the human population (including sensitive subgroups) that is likely to be without an appreciable risk of deleterious noncancer effects during a lifetime. The inhalation RfC is analogous to the oral RfD, but it provides a continuous inhalation exposure estimate. The inhalation RfC considers toxic effects for the respiratory system (portal of entry) and for effects peripheral to the respiratory system (extra respiratory or systemic effects). It is generally expressed in units of mg/m<sup>3</sup>.

The carcinogenicity assessment provides information on the carcinogenic hazard potential of the substance in question and quantitative estimates of risk from oral exposure and inhalation exposure. The information includes a weight-of-evidence judgment of the likelihood that the agent is a human carcinogen and the conditions under which the carcinogenic effects may be expressed. Quantitative risk estimates are presented in three ways. The *slope factor* is the result of application of a low-dose extrapolation procedure and is presented as the risk per mg/kg-day. The *unit risk* is the quantitative estimate in terms of either risk per : g/L drinking water or risk per : g/m<sup>3</sup> air breathed. Another form in which risk is presented is a drinking water or air concentration providing cancer risks of 1 in 10,000, 1 in 100,000, or 1 in 1,000,000.

Development of these hazard identification and dose-response assessments for chlorine dioxide and chlorite has followed the general guidelines for risk assessment as set forth by the National Research Council (1983). EPA guidelines that were used in the development of this assessment may include the following: *Guidelines for Carcinogen Risk Assessment* (U.S. EPA, 1986a); *Guidelines for the Health Risk Assessment of Chemical Mixtures* (U.S. EPA, 1986b); *Guidelines for Mutagenicity Risk Assessment* (U.S. EPA, 1986c); *Guidelines for Developmental Toxicity Risk Assessment* (U.S. EPA, 1991); *Guidelines for Neurotoxicity Risk Assessment* (U.S. EPA, 1998a); *Proposed Guidelines for Carcinogen Risk Assessment* (U.S. EPA, 1996a); *Reproductive Toxicity Risk Assessment Guidelines* (U.S. EPA, 1996b); *Recommendations for and Documentation of Biological Values for Use in Risk Assessment* (U.S. EPA, 1988); (proposed) *Interim Policy for Particle Size and Limit Concentration Issues in Inhalation Toxicity* (U.S. EPA, 1994a); *Methods for Derivation of Inhalation Reference Concentrations and Application of Inhalation Dosimetry* (U.S. EPA, 1994b); *Peer Review and Peer Involvement at the U.S. Environmental Protection Agency* (U.S. EPA, 1994c); *Use of the Benchmark Dose Approach in Health Risk Assessment* (U.S. EPA, 1995); *Science Policy Council Handbook: Peer Review* (U.S.

EPA, 1998b); and a memorandum from EPA Administrator, Carol Browner, dated March 21, 1995, Subject: Guidance on Risk Characterization.

Literature search strategies employed for these compounds were based on the CASRN and at least one common name. At a minimum, the following databases were searched: RTECS, HSDB, TSCATS, CCRIS, GENETOX, EMIC, EMICBACK, DART, ETICBACK, TOXLINE, CANCERLINE, MEDLINE, and MEDLINE backfiles. Any pertinent scientific information submitted by the public to the IRIS Submission Desk was also considered in the development of this document.

## **2. CHEMICAL AND PHYSICAL INFORMATION RELEVANT TO ASSESSMENTS**

Chlorine dioxide ( $\text{ClO}_2$ ; CASRN 10049-04-4) is a yellow to reddish-yellow gas at room temperature that is stable in the dark but is unstable in light. It is a strong oxidizing agent that under oxidant demand conditions is readily reduced to chlorite ( $\text{ClO}_2^-$ ; CASRN 7758-19-2), another strong oxidizing agent. The *Drinking Water Criteria Document on Chlorine Dioxide, Chlorite, and Chlorate* (U.S. EPA, 1994d) provides the relevant information concerning dissociation byproducts of chlorine dioxide in water. The strong oxidizing ability of chlorine dioxide makes it useful as a drinking water disinfectant. Other uses of chlorine dioxide include bleaching textiles and wood pulp for paper manufacturing, antimicrobial applications, and reducing loads of adsorbable organic halogenated compounds in industrial effluents. Chlorite is also used for etching printed circuit boards. The physical and chemical properties of chlorine dioxide and chlorite are presented in Table 1.

Chlorine dioxide and chlorite are characterized together in this report because studies conducted with chlorite, the predominant degradation product of chlorine dioxide, are likely relevant to characterizing the toxicity of chlorine dioxide. In addition, studies conducted with chlorine dioxide may be relevant to characterizing the toxicity of chlorite. Chlorine dioxide is fairly unstable and rapidly dissociates, predominantly into chlorite and chloride, and to a lesser extent, chlorate. There is a ready interconversion among these species in water (before administration to animals) and in the gut (after ingestion) (U.S. EPA, 1994d). Therefore, what exists in water or the stomach is a mixture of these chemical species (i.e., chlorine dioxide, chlorite, chlorate) and possibly their reaction products with the gastrointestinal contents.

**Table 1. Physical and chemical properties of chlorine dioxide and chlorite**

Properties	Chlorine dioxide	Chlorite (sodium salt)
CAS registry number	10049-04-4	7758-19-2
Molecular formula	ClO <sub>2</sub>	NaClO <sub>2</sub>
Molecular weight	67.46	90.45
Melting point, °C	-59	decomposes at 180–200
Boiling point, °C	11	no data
Water solubility, g/L	3.0 at 25°C and 34 mmHg	39 at 30°C
Specific gravity	1.642 at 0°C	no data

Source: Budavari et al., 1989.

### 3. TOXICOKINETICS RELEVANT TO ASSESSMENTS

#### 3.1. ABSORPTION

##### 3.1.1. Gastrointestinal Absorption

###### 3.1.1.1. Chlorine Dioxide

After ingestion, chlorine dioxide is rapidly absorbed from the gastrointestinal tract. Levels of radioactive chlorine in plasma peaked 1 hour after Sprague-Dawley rats were administered a single gavage dose of 100 mg/L <sup>36</sup>ClO<sub>2</sub> (approximately 1.4 mg/kg) (Abdel-Rahman et al., 1979a). Peak plasma levels were achieved 2 hours after Sprague-Dawley rats received a gavage dose of 300 mg/L <sup>36</sup>ClO<sub>2</sub> after a 15-day exposure to 100 mg/L chlorine dioxide in drinking water (Abdel-Rahman et al., 1979a). Approximately 30% of the 100 mg/L single gavage dose was excreted in the urine after 72 hours, indicating that at least 30% of the dose was absorbed (Abdel-Rahman et al., 1979a); the absorption rate constant and half time were 3.77/hour and 0.18 hours, respectively (Abdel-Rahman et al., 1982). Since total radioactivity was measured rather than identification of individual chemical entities, it was not clear from these reports whether the parent chlorine dioxide itself or the chlorite, chlorate, or chloride ion degradation products were absorbed.

###### 3.1.1.2. Chlorite

Chlorite is also rapidly absorbed from the gastrointestinal tract. Peak plasma levels of radiolabeled chlorine were reached 2 hours after administration of a single gavage dose of 10 mg/L <sup>36</sup>ClO<sub>2</sub><sup>-</sup> (approximately 0.13 mg/kg) to Sprague-Dawley rats. Using 72-hour urinary

excretion data, it can be assumed that at least 35% of the initial dose was absorbed (Abdel-Rahman et al., 1984a). The absorption rate constant and half-time were 0.198/hour and 3.5 hours, respectively (Abdel-Rahman et al., 1982). Since total radioactivity was measured rather than identification of individual chemical entities, it was not clear from these reports whether the parent chlorine dioxide itself or the chlorite, chlorate, or chloride ion degradation products were absorbed.

### **3.1.2. Respiratory Tract Absorption**

No data were located on respiratory tract absorption of chlorine dioxide or chlorite.

### **3.1.3. Dermal Absorption**

Scatina et al. (1984) reported on the dermal absorption of Alcide, an antimicrobial compound consisting of solutions of sodium chlorite and lactic acid, which when mixed immediately before use result in the formation of chlorine dioxide. 0.6 g  $^{36}\text{Cl}$ -labeled sodium chlorite as part of the Alcide was used to monitor absorption following application to the shaved backs of 10 female Sprague-Dawley rats. Maximum absorption of  $^{36}\text{Cl}$  into plasma was observed after 72 hours, where a plasma concentration of 69.4  $\mu\text{g}\%$   $^{36}\text{Cl}$  was reached. The absorption half-life was calculated to be 22.1 hours, which corresponds to a rate constant of 0.0314  $\text{hr}^{-1}$ .

## **3.2. DISTRIBUTION**

### **3.2.1. Chlorine Dioxide**

Following a single 100 mg/L gavage dose of  $^{36}\text{ClO}_2$ , the  $^{36}\text{Cl}$  was slowly cleared from the blood; the rate constant and half-time for elimination from blood were 0.0156/hour and 43.9 hours, respectively (Abdel-Rahman et al., 1982). Elimination from blood was shortened in Sprague-Dawley rats exposed to chlorine dioxide in drinking water for 2 weeks prior to receiving the 300 mg/L gavage dose of  $^{36}\text{ClO}_2$ ; the rate constant and half time were 0.022/hour and 31.0 hours, respectively (Abdel-Rahman et al., 1979a). After removal from the blood, the radiolabel appeared to be widely distributed throughout the body, although the highest concentrations were found in the blood, stomach, and small intestines. The lung, kidney, liver, testes (assessed only in the 300 mg/L group), spleen, thymus, and bone marrow also had high concentrations of radiolabel 72 hours after dosing with 100 mg/L (single dose) or 300 mg/L (with 2-week drinking water exposure to 100 mg/L) (Abdel-Rahman et al., 1979a). Seventy-two hours after a single gavage dose of 100 mg/L  $^{36}\text{ClO}_2$ , most of the  $^{36}\text{Cl}$  label in the plasma was in the form of chloride ion ( $\text{Cl}^-$ ) and chlorite; the ratio of chloride to chlorite was 4 to 1 (Abdel-Rahman et al., 1979b).

### **3.2.2. Chlorite**

Removal of chlorite from the blood is slow; the rate constant and half-time for elimination of  $^{36}\text{Cl}$  from the blood were 0.0197/hour and 35.2 hours in Sprague-Dawley rats receiving a single gavage dose of 10 mg/L  $^{36}\text{ClO}_2^-$  (Abdel-Rahman et al., 1982). Seventy-two hours after dosing, the highest concentrations of radiolabel were found in the blood, stomach,

testes, skin, lung, kidneys, small intestine, carcass, spleen, brain, bone marrow, and liver (Abdel-Rahman et al., 1982, 1984a).

### **3.3. METABOLISM**

#### **3.3.1. Chlorine Dioxide**

Chloride ion is the ultimate metabolite of chlorine dioxide. Approximately 87% and 80% of radiolabeled chlorine in the urine (collected 0–72 hours after administration) and plasma (collected 72 hours after administration), respectively, are in the form of chloride ion following administration of a single gavage dose of 100 mg/L  $^{36}\text{ClO}_2$  in rats (Abdel-Rahman et al., 1979b). Chlorite was a major metabolite, accounting for approximately 11% and 21% of urine and plasma  $^{36}\text{Cl}$ , respectively; approximately 2% of the urinary  $^{36}\text{Cl}$  was in the form of chlorate. An *in vivo* recovery study by Bercz et al. (1982) suggests that ingested chlorine dioxide is rapidly reduced in the stomach to nonoxidizing species (presumably chloride). Five minutes after chlorine dioxide was instilled into the stomach of a monkey, only 8% of the total oxidizing capacity equivalents of chlorine dioxide was recovered. Bercz et al. (1982) also reported that *in vitro* chlorine dioxide was rapidly reduced to chloride ion by saliva obtained from anesthetized monkeys.

#### **3.3.2. Chlorite**

Although fewer data are available on metabolism of chlorite, it is likely that metabolism of chlorite is similar to that of chlorine dioxide. Approximately 85% of the  $^{36}\text{Cl}$  recovered in the urine of Sprague-Dawley rats 0–72 hours after administration of a single gavage of 10 mg/L  $^{36}\text{ClO}_2^-$  was in the form of chloride; the remaining 15% was present as chlorite (Abdel-Rahman et al., 1984a).

### **3.4. ELIMINATION**

#### **3.4.1. Chlorine Dioxide**

The radioactive chlorine label was primarily excreted in the urine of rats administered a single gavage dose of 100 mg/L  $^{36}\text{ClO}_2$  (Abdel-Rahman et al., 1979a). During the first 24 hours after dosing, 18% of the label was excreted in the urine and 4.5% in the feces. Seventy-two hours after dosing, 31% and 10% of the label were excreted in the urine and feces, respectively; the label was not detected in expired air. The parent compound was not detected in the urine; most of the label was in the form of chloride, with smaller amounts as chlorite. The ratio of  $^{36}\text{Cl}$  to  $^{36}\text{ClO}_2^-$  was 5 to 1 during the first 24 hours and 4 to 1 during the first 72 hours (Abdel-Rahman et al., 1979b).

#### **3.4.2. Chlorite**

Urine was the primary route of excretion in rats administered a single gavage dose of 10 mg/L  $^{36}\text{ClO}_2^-$ . Twenty-four hours after dosing, 14% of the label was excreted in the urine and

0.9% in the feces; 35% and 5% of the label were excreted in the urine and feces, respectively, 72 hours after dosing (Abdel-Rahman et al., 1984a). Approximately 90% of the excreted label was in the form of chloride.

## 4. HAZARD IDENTIFICATION

### 4.1. STUDIES IN HUMANS—EPIDEMIOLOGY, CASE REPORTS, CLINICAL CONTROLS

#### 4.1.1. Oral Exposure

##### 4.1.1.1. *Chlorine Dioxide*

The short-term toxicity of chlorine dioxide was assessed in two human studies conducted by Lubbers and associates (Lubbers et al., 1981, 1982, 1984a; Bianchine et al., 1981). In the first study (Lubbers et al., 1981; also published as Lubbers et al., 1982), a group of 10 healthy male adults drank 1,000 mL (divided into two 500 mL portions, separated by 4 hours) of a 0 or 24 mg/L chlorine dioxide solution (0.34 mg/kg, assuming a 70 kg reference body weight). In the second study (Lubbers et al., 1984a), groups of 10 adult males were given 500 mL distilled water containing 0 or 5 mg/L chlorine dioxide (0.04 mg/kg-day assuming a reference body weight of 70 kg) for 12 weeks. Neither study found any physiologically relevant alterations in general health (observations and physical examination), vital signs (blood pressure, pulse rate, respiration rate, and body temperature), serum clinical chemistry parameters (including glucose, urea nitrogen, phosphorus, alkaline phosphatase, and aspartate and alanine aminotransferases), serum triiodothyronine (T3) and thyroxine (T4) levels, or hematologic parameters.

##### 4.1.1.2. *Chlorite*

Lubbers et al. (1981, 1982, 1984a) also examined the toxicity of chlorite in normal healthy adults in studies that were run concurrently with the chlorine dioxide studies. In the single exposure study (Lubbers et al., 1981, 1982), 10 male adults consumed two 500 mL (separated by 4 hours) solutions containing 2.4 mg/L chlorite (0.034 mg/kg assuming a reference body weight of 70 kg). In a 12-week study (Lubbers et al., 1984a), groups of 10 men drank 500 mL solutions of 0 or 5 mg/L chlorite (0.04 mg/kg-day assuming a 70 kg body weight). No physiologically relevant alterations in general health (observations and physical examination), vital signs, hematologic (including erythrocyte and total and differential leukocyte counts, hemoglobin, hematocrit, and methemoglobin) or serum clinical chemistry (including glucose, electrolytes, calcium, urea nitrogen, enzyme levels, and cholesterol) parameters, or serum T3 or T4 levels were found in either study.

In a companion study, three healthy glucose-6-phosphate dehydrogenase deficient male subjects were given deionized water containing 5 mg/L chlorite (0.04 mg/kg-day assuming a reference body weight of 70 kg) for 12 weeks (Lubbers et al., 1984b). Compared with the

control group in Lubbers et al. (1984a), the chlorite exposure did not alter general health, vital signs, hematologic parameters (including erythrocyte and total and differential leukocyte counts, hemoglobin, hematocrit, and methemoglobin) or serum clinical chemistry (including glucose, electrolytes, calcium, urea nitrogen, enzyme levels, and cholesterol) parameters.

#### **4.1.1.3. Chlorine Dioxide–Disinfected Water**

Michael et al. (1981), Tuthill et al. (1982), and Kanitz et al. (1996) have examined communities with chlorine dioxide disinfected water. The focus of the Tuthill et al. (1982) and Kanitz et al. (1996) studies was developmental toxicity. Michael et al. (1981) measured hematologic (erythrocyte, leukocyte, and reticulocyte counts, hemoglobin and methemoglobin levels, hematocrit, mean corpuscular volume, and osmotic fragility) and serum chemistry (blood urea nitrogen and total bilirubin levels) parameters in 198 individuals 1 week before the community initiated the chlorine dioxide water treatment program and 10 weeks after initiation. Blood samples were collected at the same times from a control group of 118 individuals not exposed to chlorine dioxide–treated drinking water. The water treatment facility operated only 8 hours/day; water was drawn from storage tanks for the rest of the day. Chlorine dioxide rapidly disappeared from the stored water (within 2–4 hours), and chlorite levels concomitantly increased. Weekly average concentrations (presumably measured during plant operation hours) of chlorine dioxide ranged from 0.25 to 1.11 ppm, and chlorite concentrations ranged from 3.19 to 6.96 ppm (daily mean chlorite concentration was 5.21 ppm). Using measured water consumption rates (1.98 L/day), the study authors estimated that daily chlorite intakes ranged from 0 to 39.4 mg/day (0–0.56 mg/kg-day assuming a 70 kg reference body weight); the mean intake was 10.3 mg/day (0.15 mg/kg-day). The difference between pre- and posttreatment blood urea nitrogen levels was lower in the community with chlorine dioxide–disinfected water than in the control community. However, the study authors noted that this difference was probably because mild dehydration had occurred in the control community, the postinitiation sample was taken during extremely hot weather, and more individuals in the control group had active, outdoor jobs. No other hematologic or serum chemistry alterations were found.

Tuthill et al. (1982) retrospectively compared infant morbidity and mortality data for a community that had utilized “high” levels of chlorine dioxide as a drinking water disinfectant in the 1940s with data of a neighboring community using conventional drinking water chlorination practices. The authors reported average monthly levels of 0.32 ppm of sodium chlorite added post-treatment, but they did not report chlorine dioxide levels in the treated water. Exposure to chlorine dioxide–treated water did not adversely affect fetal, neonatal, postneonatal, or infant mortality, nor did it affect birthweight, sex ratio, or birth condition. Incidence of newborns judged premature by physician assessment was significantly higher in the community with chlorine dioxide–treated water. In reviewing this study, EPA (1994d) concluded there was no increase in the proportion of premature infants when the age of the mother was controlled and that there was a greater postnatal weight loss in infants from the exposed community.

Kanitz et al. (1996) followed 548 births at Galliera Hospital, Genoa, and 128 births at Chiavari Hospital, Chiavari, Italy, during 1988–1989. Data on infant birthweight, body length, cranial circumference, and neonatal jaundice and on maternal age, smoking, alcohol

consumption, education, and preterm delivery were collected from hospital records. Women in Genoa were exposed to filtered water disinfected with chlorine dioxide, sodium hypochlorite, or both; trihalomethane levels varied from 8 to 16 ppb in sodium hypochlorite-treated water and 1 to 3 ppb in chlorine dioxide-disinfected water. Levels of chlorine dioxide in the water immediately after treatment were less than 0.3 mg/L, while chlorine residue was less than 0.4 mg/L. Women residing in Chiavari used water pumped from wells, without any disinfection treatment, and served as the comparison group (controls). Odds ratios were determined for the somatic parameters by comparison of groups exposed to chlorine dioxide, sodium hypochlorite, or both with controls and adjusted for maternal education level, income, age, and smoking and for sex of the child. Neonatal jaundice occurred more frequently (odds ratio [OR] = 1.7; 95% confidence interval [CI] = 1.1–3.1) in infants whose mothers resided in the area where surface water was disinfected with chlorine dioxide, when compared with infants with mothers using nondisinfected well water. Infants born to mothers residing in areas where surface water was disinfected had smaller cranial circumference (# 35 cm) (OR = 2.2, 95% CI = 1.4–3.9 for chlorine dioxide; OR = 3.5, 95% CI = 2.1–8.5 for sodium hypochlorite vs. untreated well water; OR = 2.4, 95% CI = 1.6–5.3 for both vs. untreated well water). In addition, these infants had a smaller body length (# 49.5 cm) (OR = 2.0, 95% CI = 1.2–3.3 for chlorine dioxide vs. untreated well water; OR = 2.3, 95% CI = 1.3–4.2 for sodium hypochlorite vs. untreated well water). Risks for low-birthweight infants (# 2,500 g) were reported to be increased in mothers residing in areas using water disinfected with chlorite and chlorine dioxide, but these associations were not statistically significant. For preterm delivery (# 37 weeks), small but not statistically significant increased risks were found among mothers residing in the area using chlorine dioxide. The study authors concluded that infants of women who consumed drinking water treated with chlorine compounds during pregnancy were at higher risk for neonatal jaundice, cranial circumference # 35 cm, and body length # 49.5 cm.

Interpretability of the results of Kanitz et al. (1996) is limited by lack of consideration of exposure and potential confounding variables such as quantity of water consumed during pregnancy, lack of quantitative exposure information, exposure to other chemicals in the water, and nutritional and smoking habits and age distribution of the women. In addition, baseline values for the infant sex ratio and percentage of low-weight births for the comparison group deviate from values presented by the World Health Organization for Italy. For example, the sex ratio (male/female live births \* 100) used in the study for the comparison group was 86, but most recent data (for 1996, as cited in WHO, 2000) for Italy indicate a sex ratio value of 113. Although the percentage of low-weight births in the control group for the Kanitz et al. (1996) study was 0.8%, the percentage of low-weight births (< 2,500 g) in Italy for 1994 is 6%. The quality of the untreated well water is not known (i.e., whether it contained any chemical or biological contaminants). The atypical baseline data raise concerns about the control population selected for this study and render any comparison to them by the exposed group difficult to interpret, thereby precluding the ability to draw conclusions (Selevan, 1997).



## 4.1.2. Inhalation Exposure

### 4.1.2.1. Chlorine Dioxide

Several case reports of accidental inhalation exposure to chlorine dioxide have been reported in the literature. Elkins (1959) described the case of a bleach tank worker who died after being exposed to 19 ppm chlorine dioxide ( $52 \text{ mg/m}^3$ ) for an unspecified amount of time; another worker exposed at the same time survived. Elkins also stated that 5 ppm ( $14 \text{ mg/m}^3$ ) was definitely irritating to humans. In a case reported by Exner-Freisfeld et al. (1986), a woman experienced coughing, pharyngeal irritation, and headache after inhaling an unknown amount of chlorine dioxide inadvertently generated while bleaching flowers. Seven hours after exposure, the woman was hospitalized with cough, dyspnea, tachypnea, tachycardia, rales on auscultation, and marked leukocytosis; a decrease in lung function (reduced vital capacity and 1-second forced expiratory volume) was also reported. Most of these symptoms were alleviated with corticosteroid treatment.

Meggs et al. (1996) examined 13 individuals (1 man and 12 women) 5 years after they were occupationally exposed to chlorine dioxide from a leak in a water purification system pipe. The long-term effects of the accident included development of sensitivity to respiratory irritants (13 subjects), disability with loss of employment (11 subjects), and chronic fatigue (11 subjects). Nasal abnormalities (including injection, telangiectasia, paleness, cobblestoning, edema, and thick mucus) were found in all 13 individuals. Nasal biopsies taken from the subjects revealed chronic inflammation with lymphocytes and plasma cells present within the lamina propria in 11 of the 13 subjects; the inflammation was graded as mild in 2 subjects, moderate in 8 subjects, and severe in 1 subject. Nasal biopsies from three control subjects showed chronic inflammation in one subject. The average inflammation grading was statistically higher in the subjects compared with the controls. The number of nerve fibers in the biopsies was higher in the subjects (rare fibers in three subjects, moderate fibers in two subjects, and many fibers in three subjects) than controls, but the difference was not statistically significant.

Gloemme and Lundgren (1957), Ferris et al. (1967), and Kennedy et al. (1991) examined workers occasionally exposed to high concentrations of chlorine dioxide that resulted from equipment failure. Concurrent exposure to chlorine gas and, in some cases, sulfur dioxide confounds interpretation of the results of these studies. Gloemme and Lundgren (1957) examined the respiratory health of 12 workers employed at a sulfite-cellulose production facility. Under normal working conditions, the atmospheric chlorine content was less than 0.1 ppm (chlorine dioxide levels were not measured); however, occasional equipment leakages would result in high levels of chlorine dioxide, chlorine, and/or sulfur dioxide. The workers reported respiratory discomfort (breathlessness, wheezing, irritant cough) and ocular discomfort (conjunctivitis and “halo phenomena”) connected with these leakage exposures. A slight, nonspecific chronic bronchitis was diagnosed in 7 of the 12 men. An earlier-observed bronchitis disappeared in one case, suggesting to the study authors that improved working conditions might entail reversal of this disorder.

In the Ferris et al. (1967) study, no significant alterations in pulmonary function (forced vital capacity, maximum expiratory flow, forced expiratory flow, and forced expiratory volume) were observed in 147 men employed (length of employment not reported) at a pulp mill, compared with 124 men employed at a paper mill. The pulp mill workers were exposed to sulfur dioxide or chlorine dioxide and chlorine; the chlorine dioxide concentrations ranged from trace amounts to 2 ppm (average concentrations ranged from trace amounts to 0.25 ppm), and chlorine concentrations ranged from trace amounts to 64 ppm (average concentrations ranged from trace amounts to 7.4 ppm). When the pulp mill workers were divided into workers exposed to sulfur dioxide and those exposed to chlorine or chlorine dioxide, significantly higher incidences of shortness of breath and excess phlegm were found in the chlorine/chlorine dioxide workers.

In the Kennedy et al. (1991) study of 321 pulp mill workers exposed to chlorine and chlorine dioxide, significant increases in the incidence of wheezing, wheezing accompanied by breathlessness, and work-related wheezing were observed, compared with 237 workers at a rail maintenance yard. Personal time-weighted average (TWA) exposure concentration for chlorine at the pulp mill ranged from 5 to 14 ppm, whereas TWA for chlorine dioxide was below 0.1 ppm. However, 60% of the pulp mill workers reported one or more chlorine or chlorine dioxide “gassing” incidents. No significant differences in tests of pulmonary function were observed between the two groups. The pulp mill workers were divided into two groups based on self-reported accidental exposures to high levels of chlorine/chlorine dioxide gas (“gassing”). In the workers reporting one or more incidents of gassing, the prevalence of wheezing and missed work because of chest illness was higher than in the pulp mill workers not reporting gassing incidents. Additionally, the incidence of airflow obstruction (as measured by a decrease in midmaximal flow rate and the ratio of 1-second forced expiratory volume to forced vital capacity) was higher in nonsmokers and former smokers reporting gassing incidents compared with smokers also reporting gassing incidents.

#### **4.1.2.2. Chlorite**

No human inhalation exposure data for chlorite were located.

## **4.2. PRECHRONIC AND CHRONIC STUDIES AND CANCER BIOASSAYS IN ANIMALS—ORAL AND INHALATION**

### **4.2.1. Oral Exposure**

#### **4.2.1.1. Chlorine Dioxide**

Although the subchronic/chronic toxicity of chlorine dioxide has been investigated in a number of studies, only Daniel et al. (1990) and Haag (1949) examined a wide range of endpoints. The other studies (Bercz et al., 1982; Abdel-Rahman et al., 1984b; Couri and Abdel-Rahman, 1980; Moore and Calabrese, 1982) focused on the hematologic system. To date, no studies have examined the carcinogenic potential of chlorine dioxide.

Daniel et al. (1990) exposed groups of 10 male and 10 female Sprague-Dawley rats to chlorine dioxide in drinking water for 90 days at concentrations of 0, 25, 50, 100, or 200 mg/L. These concentrations correspond to administered doses of 0, 2, 4, 6, or 12 mg/kg-day chlorine dioxide for males and 0, 2, 5, 8, or 15 mg/kg-day chlorine dioxide for females (calculated by the study authors using water consumption and body weight data). No exposure-related deaths were reported. Exposure to 200 mg/L resulted in significant reductions in terminal body weights and body weight gain (26%–29% lower than controls). Significant reductions in water consumption were observed in the males exposed to 50 mg/L and in females exposed to 25 mg/L; decreases in food consumption were also observed in the 200 mg/L males. Absolute liver weights were decreased in males at 50 mg/L, and absolute spleen weights were decreased in females at 25 mg/L. No consistent alterations in hematologic parameters (erythrocyte and total and differential leukocyte counts, hemoglobin levels, hematocrit, and mean corpuscular volume measured) were observed. Serum lactate dehydrogenase and aspartate aminotransferase levels were decreased and serum creatinine levels were increased in the males exposed to 100 or 200 mg/L; no other alterations in serum chemistry parameters were consistently found. A significant increase in incidence of nasal lesions (goblet cell hyperplasia and inflammation of nasal turbinates) was found in males exposed to 25 mg/L and in females at 100 mg/L. The study authors postulated that these lesions were likely caused by inhalation of chlorine dioxide vapors at the drinking water sipper tube or from off-gassing of the vapors after drinking rather than ingestion of the drinking water. Thus, 25 mg/L (2 mg/kg-day) can be described as a lowest-observed-adverse-effect level (LOAEL), but the toxicological significance of the nasal lesions is not known. Respiratory tract pathologies have not been reported in other oral studies and the effect may possibly be an artifact of treatment.

In a chronic toxicity study by Haag (1949), groups of seven male and seven female rats were exposed to 0, 0.5, 1, 5, 10, or 100 mg/L chlorine dioxide in drinking water (0.07, 0.13, 0.7, 1.3, or 13 mg/kg-day as calculated by U.S. EPA, 1994d) for 2 years. Survival in the 100 mg/L group was significantly decreased. No chlorine dioxide-related alterations were observed in the histopathologic examination of representative animals (2–6/sex) from each group. Thus, a no-observed-adverse-effect level (NOAEL) of 10 mg/L (1.3 mg/kg-day) and a frank effect level (FEL) (based on decreased survival) of 100 mg/L (13 mg/kg-day) can be identified from this study.

The Bercz et al. (1982) study used a rising-dose design in which each animal served as its own control. Five male and seven female adult African green monkeys (*Cercopithecus aethiops*) were exposed to 0, 30, 100, and 200 mg/L chlorine dioxide for 4–6 weeks. The study authors estimated chlorine dioxide administered doses to be 3.5 and 9.5 mg/kg-day in the 30 and 100 mg/L groups, respectively. Exposure to 200 mg/L resulted in erythema and ulceration of the oral mucosa, mucous nasal discharge, and avoidance of drinking water; exposure to 200 mg/L was terminated after 1 week because some of the animals showed signs of dehydration. No significant alterations in hematologic clinical chemistry (erythrocyte, total and differential leukocyte, and reticulocyte counts, hemoglobin levels, hematocrit, osmotic fragility, and methemoglobin levels) or serum clinical chemistry (creatinine, blood urea nitrogen [BUN], alkaline phosphatase, lactate dehydrogenase, and alanine and aspartate aminotransferase) parameters or body weight gain were observed. Serum T4 levels were significantly decreased in

the 100 mg/L chlorine dioxide-exposed monkeys after 6 weeks of exposure. Thus, this study identifies a NOAEL of 30 mg/L (3.5 mg/kg-day) and a LOAEL of 100 mg/L (9.5 mg/kg-day) for alterations in thyroid hormone levels in monkeys exposed to chlorine dioxide in the drinking water for 4–6 weeks.

Abdel-Rahman et al. (1984b) exposed groups of four male Sprague-Dawley rats to 0, 1, 10, 100, or 1,000 mg/L chlorine dioxide in the drinking water 20 hours/day for 11 months (doses of 0.10, 1, 10, and 100 mg/kg-day are estimated using a reference body weight of 0.523 kg and reference water intake of 0.062 L/day and adjusting for intermittent exposure). Significant reductions in body weight gain were observed in the 1,000 mg/L group at 2, 5, 7, 10, and 11 months and in all groups during months 10 and 11. A number of statistically significant hematologic alterations were observed; however, the magnitude of the alterations does not appear to be dose related. Osmotic fragility was decreased in the 100 and 1,000 mg/L groups after 2, 4, 7, or 9 months of exposure and in the 10 mg/L group only after 9 months of exposure. Erythrocyte counts were decreased in the 1 and 1,000 mg/L groups after 9 months of exposure, but not after 7 months. Reduced hematocrit and hemoglobin levels were observed in all groups at 9 months; hematocrit levels were significantly increased in the 100 and 1,000 mg/L groups at 7 months. Mean corpuscular hemoglobin concentrations were increased in the 100 and 1,000 mg/L groups after 9 months. Blood glutathione levels were significantly reduced in the 1, 10, and 1,000 mg/L groups at 2 months; the 1 and 10 mg/L groups after 4 months; the 1 mg/L group after 7 months; and the 100 mg/L group after 9 months. DNA synthesis (assessed using <sup>3</sup>H-thymidine incorporation) was significantly reduced in the kidneys of rats exposed to 100 mg/L, decreased in the testes of rats in the 10 and 100 mg/L groups, and increased in the intestinal mucosa of rats exposed to 10 or 100 mg/L chlorine dioxide; thymidine incorporation was not significantly altered in the liver. The lack of a consistent relationship between dose and hematologic alterations and the small number of animals (four males/group) confound interpretation of the study.

Couri and Abdel-Rahman (1980) found significant increases in blood glutathione reductase levels in Sprague-Dawley rats (four males/group) exposed to 10, 100, or 1,000 mg/L chlorine dioxide in drinking water 20 hours/day, 7 days/week for up to 1 year (0, 0.1, 1, 10, or 100 mg/kg-day using reference body weights and drinking water intakes of 0.523 kg and 0.062 L/day, respectively, and adjusting for intermittent exposure). After 12 months of exposure, the erythrocyte glutathione reductase levels in rats exposed to 1, 10, 100, or 1,000 mg/L were similar to those of controls, but the levels of erythrocyte glutathione peroxidase were significantly increased at 100 and 1,000 mg/L. Erythrocyte glutathione concentrations were significantly decreased at 1, 10, and 100 mg/L after 6 months and at 1,000 mg/L after 12 months of exposure. Erythrocyte catalase levels were increased in the 1,000 mg/L group after 6 and 12 months of exposure and decreased in the 1 and 10 mg/L groups after 6 months of exposure.

In similarly exposed Swiss Webster mice (six males/group) (estimated doses of 0.18, 1.8, 18, and 180 mg/kg-day [as calculated by U.S. EPA, 1994d] for 1, 10, 100, and 1,000 mg/L chlorine dioxide, respectively, drinking water concentrations), glutathione peroxidase levels were decreased at 100 mg/L and increased at 1,000 mg/L after 12 months of exposure, and glutathione levels were decreased at 10 and 100 mg/L after 12 months (Couri and Abdel-Rahman, 1980).

Catalase levels were increased in the 10, 100, and 1,000 mg/L groups after 12 months of exposure. As with the Abdel-Rahman et al. (1984b) study, the inconsistent relationship between the dose and the magnitude of the alterations in the glutathione-dependent system makes interpretation of the results of this study difficult; additionally, it is not clear if these effects are biologically significant, precluding determination of a NOAEL and LOAEL for these studies.

Moore and Calabrese (1982) exposed groups of 10 A/J or C57L/J mice (sex not specified) to 0 or 100 ppm chlorine dioxide in drinking water for 30 days (0 or 19 mg/kg-day using a reference body weight of 0.0316 kg and water intake of 0.0078 L/day). No significant alterations in hematologic parameters (complete blood count, reticulocyte count, glucose-6-phosphate activity, and osmotic fragility) were observed in either mouse strain.

#### **4.2.1.2. Chlorite**

The database for chlorite subchronic/chronic systemic toxicity consists of the Harrington et al. (1995a) subchronic study, the Haag (1949) chronic study, and the Bercz et al. (1982), Abdel-Rahman et al. (1984b), Couri and Abdel-Rahman (1980), and Moore and Calabrese (1982) studies, which examined a limited number of endpoints. Kurokawa et al. (1986) is the only study that examined the carcinogenic potential of ingested chlorite.

Harrington et al. (1995a) administered doses of 0, 10, 25, or 80 mg/kg-day sodium chlorite (equivalent to 0, 7.4, 19, or 60 mg chlorite/kg-day, respectively) via gavage to Crl:CD (SD) BR rats (15/sex/group) for 13 weeks. In the 60 mg/kg-day group, four animals died during treatment and both sexes exhibited salivation, significantly decreased erythrocyte counts, and decreased total serum protein levels. The males receiving 60 mg/kg-day exhibited significantly decreased hematocrit and hemoglobin levels and increased methemoglobin and neutrophil levels, whereas in the females, methemoglobin levels were significantly decreased. Possible reasons for the decrease in methemoglobin in females, which is unexpected considering the known oxidative effects of sodium chlorite, were not discussed by the study authors. The following observations were also noted in the 60 mg/kg-day group: morphological changes in erythrocytes in some animals of both sexes, significant increases in relative adrenal and spleen weights in the males, increases in absolute and relative spleen and adrenal weight in females, and increases in relative liver and kidney weights in the females. Body weight and food consumption were not affected by treatment. Histopathologic alterations in the 60 mg/kg-day group included squamous epithelial hyperplasia, hyperkeratosis, ulceration, chronic inflammation, and edema in the stomachs of seven males and eight females. At 19 mg/kg-day, the following alterations were reported: occasional salivation in two males, hematologic alterations in males (increased methemoglobin levels and neutrophil count, decreased lymphocyte count), increases in absolute and relative spleen and adrenal weights in females, and histologic alterations in the stomach of two males, similar to those seen in the high-dose group. The increase in absolute splenic weight was attributed to morphological alterations in erythrocytes, but no explanation was provided for alterations in absolute adrenal weight. The NOAEL in this study is determined to be 7.4 mg/kg-day, and the LOAEL is 19 mg/kg-day for stomach lesions and increases in spleen and adrenal weights in rats subchronically treated with sodium chlorite.

In a chronic study by Haag (1949), groups of rats (seven/sex/group) were exposed to 0, 1, 2, 4, 8, 100, or 1,000 mg/L chlorite in the drinking water (0, 0.09, 0.18, 0.35, 0.7, 9.3, or 81 mg/kg-day, as calculated by U.S. EPA, 1994d) for 2 years. Animals exposed to chlorite concentrations of 100 or 1,000 mg/L exhibited treatment-related renal pathology, characterized by distention of the glomerular capsule and appearance of a pale pinkish staining material in the renal tubules. These effects were also observed in a group of animals administered sodium chloride at a concentration equimolar to 1,000 mg sodium chlorite/L. The study author concluded that the renal pathology was a nonspecific salt effect, but this observation does not alter the observation that concentrations of 100 mg/L or higher led to adverse effects. Based on renal effects, this study identifies a NOAEL of 8 mg/L (0.7 mg/kg-day) and a LOAEL of 100 mg/L (9.3 mg/kg-day). The study was limited because an insufficient number of animals were tested per group, pathology was conducted on a small number of animals, and it did not provide adequate evaluations of more sensitive parameters, which would have been more useful in the overall assessment of chronic toxicity.

Two similarly designed studies, by Abdel-Rahman et al. (1984b) and Couri and Abdel-Rahman (1980), tested the hematotoxicity of chlorite in rats. Groups of four male Sprague-Dawley rats were exposed to 0, 10, or 100 mg/L chlorite in drinking water 20 hours/day, 7 days/week for up to 1 year (0, 1, or 10 mg/kg-day using a reference body weight of 0.523 kg and water intake rate of 0.062 L/day) and adjusting for intermittent exposure. At all measuring periods (after 2, 5, 7, 10, and 11 months of exposure), there were significant decreases in body weight gain in the 100 mg/L group; body weight gain also was decreased in the 10 mg/L group at 10 and 11 months. The study authors do not note whether water consumption was affected. No consistent alterations in erythrocyte count, hematocrit, or hemoglobin levels were observed. Mean corpuscular hemoglobin concentration was increased at both exposure levels after 7 months of exposure, but not after 9 months. Osmotic fragility was significantly decreased at 10 and 100 mg/L after 7 and 9 months of exposure. DNA synthesis (as measured by <sup>3</sup>H-thymidine incorporation) was decreased in the liver and testes at 10 and 100 mg/L, decreased in the intestinal mucosa at 100 mg/L, and increased in the intestinal mucosa at 10 mg/L. Blood glutathione reductase activity was significantly increased at 10 and 100 mg/L after 6 months of exposure and decreased at 10 mg/L after 12 months. Blood glutathione peroxidase was not altered after 6 months of exposure, but after 12 months it was decreased in both groups. Significant decreases in blood glutathione levels were observed in both groups. Blood catalase activity was decreased after 6 months of exposure in the 10 and 100 mg/L groups and increased in the 10 mg/L groups after 12 months. The lack of a consistent dose-effect relationship, small numbers of animals, and small magnitude of effects complicate interpretation of the results.

Moore and Calabrese (1982) also examined the hematotoxicity of chlorite. In this study, groups of 11–23 A/J or C57L/J mice (sex not specified) were exposed to 0, 1, 10, or 100 ppm sodium chlorite (0, 0.75, 7.5, or 75 ppm chlorite) in drinking water for 30 days. Significant increases in mean corpuscular volume, osmotic fragility, and glucose-6-phosphate activity were observed in both strains of mice exposed to 100 ppm; no other alterations in hematologic parameters were observed. This study identifies a NOAEL of 10 ppm sodium chlorite (1.9 mg/kg-day chlorite using a reference body weight of 0.0316 kg and water intake of 0.0078 L/day)

and a LOAEL of 100 ppm sodium chlorite (19 mg/kg-day) for hematologic effects in mice exposed to chlorite in drinking water for 30 days.

Using a rising-dose study protocol, Bercz et al. (1982) examined the effects of subchronic exposure to sodium chlorite in drinking water on hematologic and serum clinical chemistry parameters. Five male and seven female adult African green monkeys (*C. aethiops*) were exposed to 0, 25, 50, 100, 200, or 400 mg/L chlorite in drinking water for 4–6 weeks; the study authors estimated the dose for the 400 mg/L group to be 58.4 mg/kg-day. Each animal served as its own control. A number of statistically significant, dose-related alterations in hematologic and serum clinical chemistry parameters were observed. These included decreases in erythrocyte levels and cell indices, increases in aspartate aminotransferase (increases were subclinical), slight decreases in hemoglobin levels, and slight increases in reticulocyte count and methemoglobin levels. The data were not presented in a manner that would allow identification of threshold doses for the hematologic alterations. Other hematologic and clinical chemistry parameters and body weight were not affected. Serum T4 levels were significantly reduced in the 400 mg/L group.

To assess the renal toxicity of sodium chlorite, Moore and Calabrese (1982) exposed groups of 55–60 male C57L/J mice to 0, 4, 20, or 100 ppm sodium chlorite (0, 3, 15, or 75 ppm chlorite) in the drinking water for 30, 90, or 190 days. No significant alterations in body weight gain, absolute or relative kidney weights, water consumption, or kidney histology were observed.

In an oral carcinogenicity study conducted by Kurokawa et al. (1986) (mouse data were also presented in Yokose et al., 1987), groups of male and female F344 rats and B6C3F1 mice (50/sex/species/group) were exposed to sodium chlorite in the drinking water for 85 or 80 weeks (with a 5-week recovery period) (Yokose et al., 1987). The sodium chlorite concentrations were 0, 300, or 600 ppm for rats and 0, 250, or 500 ppm for mice. Using water consumption and body weight data, the study authors estimated the doses to be 18 and 32 mg/kg-day in male rats and 28 and 41 mg/kg-day in female rats. All groups of rats were infected with the Sendai virus. No adverse effect on survival was observed in the rats. A slight dose-related decrease in body weight gain was observed (body weight gain in the high-dose group was within 10% of controls). No chlorite-related increases in tumor incidence were observed in the rats.

For mice, daily doses of 0, 48, and 95 mg sodium chlorite/kg-day (0, 36, and 71 mg chlorite/kg-day) were calculated by EPA (1994d). In the mice, there were no significant chlorite-related alterations in survival or body weight gain; increased mortality was observed in the male control group, which was attributed to severe fighting. Significant increases in liver and lung tumors were observed in the male mice. Incidence of hyperplastic nodules in the liver was significantly increased in the low- and high-dose groups relative to controls (3/35 [reported as 6/35 in Yokose et al., 1987], 14/47, 11/43, in the control, low-, and high-dose groups, respectively) and combined incidence of liver hyperplastic nodules and hepatocellular carcinoma was increased in the low-dose group (7/35, 22/47, and 17/43, respectively). Incidence of lung adenoma (0/35, 2/47, and 5/43, respectively) and combined incidence for lung adenoma and adenocarcinoma (0/35, 3/47, and 7/43, respectively) were significantly increased in the high-dose group compared with controls. The study authors noted that incidences of liver hyperplastic

nodules and lung adenomas in the treated animals were within the range of historical controls in their laboratory and in the National Toxicology Program laboratories. The high mortality in the control males because of fighting may have contributed to the low tumor incidence in the concurrent control group, making statistical comparisons between concurrent controls and treated animals difficult to interpret. In the female mice, the only significant alteration in tumor incidence was a significantly lower incidence of malignant lymphoma/leukemia in the high-dose group (7/47, 5/50, 1/50, respectively). This study is considered inadequate for assessing carcinogenicity because of the relatively short exposure duration (80 weeks) and the high incidence of early mortality in the concurrent control males from excessive fighting.

#### **4.2.2. Inhalation Exposure**

##### **4.2.2.1. Chlorine Dioxide**

Paulet and Desbrousses (1970) conducted four studies to investigate toxicity of inhaled chlorine dioxide in rats and rabbits (strains not specified): (1) 5 male and 5 female rats were exposed to 10 ppm chlorine dioxide ( $28 \text{ mg/m}^3$ ) 2 hours/day for 30 days; (2) 10 male rats, 10 female rats, and 4 rabbits were exposed to 5 ppm chlorine dioxide ( $14 \text{ mg/m}^3$ ) 2 hours/day for 30 days; (3) 10 male and 10 female rats were exposed to 2.5 ppm chlorine dioxide ( $6.9 \text{ mg/m}^3$ ) 7 hours/day for 30 days; and (4) 8 rabbits were exposed to 2.5 ppm chlorine dioxide ( $6.9 \text{ mg/m}^3$ ) 4 hours/day for 45 days. The weekly exposure frequency was not reported—presumably it was 5 days/week. Control groups with equal numbers of animals were used for each study. The following adverse effects were observed at 10 ppm: nasal discharge and red eyes, localized bronchopneumonia with desquamation of the alveolar epithelium, and significantly increased blood erythrocyte and leukocyte levels. Similar, but less severe, respiratory tract effects were observed at 5 ppm; there were no alterations in erythrocyte or leukocyte levels at this concentration. Lymphocytic infiltration of the alveolar spaces, alveolar vascular congestion, hemorrhagic alveoli, epithelial erosions, and inflammatory infiltrations of the bronchi were observed in the rats exposed to 2.5 ppm. The study authors noted that body weight gain was “slightly slowed” (data not presented) and the erythrocyte and leukocyte levels were 85% and 116% of controls, respectively (statistical analysis not reported), in the rats exposed to 2.5 ppm. In rabbits exposed to 2.5 ppm chlorine dioxide, hemorrhagic alveoli and congested capillaries were observed in the lungs. Body weight gain was not adversely affected, and erythrocyte and leukocyte levels were 80% and 116% of controls (statistical analysis not reported; the study authors state that the cell counts “changed very little”). Another group of rats and rabbits were sacrificed 15 days after termination of the 2.5 ppm exposure regimens. Recovery from the pulmonary lesions was evident in these animals. The liver was not adversely affected in the rats or rabbits following exposure to 2.5, 5, or 10 ppm chlorine dioxide. This study identifies a LOAEL of 2.5 ppm ( $6.9 \text{ mg/m}^3$ ) for thoracic effects (alveolar congestion and hemorrhage and bronchial inflammation) in rats (7 hours/day for 30 days) and pulmonary effects (alveolar hemorrhage and capillary congestion) in rabbits (4 hours/day for 45 days).

In a follow-up study by Paulet and Desbrousses (1972), groups of eight Wistar rats (sex not reported) were exposed to 1 ppm chlorine dioxide ( $2.8 \text{ mg/m}^3$ ) 5 hours/day, 5 days/week for 2 months. The study authors noted that weight gain and erythrocyte and leukocyte levels were



not affected, but they did not present concurrent control data. Vascular congestion and peribronchiolar edema were observed in the lungs of chlorine dioxide-exposed rats; no alterations in the epithelium or parenchyma were observed. This subchronic study identifies a LOAEL of 1 ppm (2.8 mg/m<sup>3</sup>) for respiratory effects in rats.

In a second series of studies conducted by Paulet and Desbrousses (1974), groups of 10–15 rats (sex and strain not reported) were exposed to 5, 10, or 15 ppm chlorine dioxide (14, 28, or 41 mg/m<sup>3</sup>) for 15-minute periods two or four times/day for 1 month. Control groups were similarly exposed to room air. At 15 ppm, 1/10 and 1/15 rats exposed two or four times/day, respectively, died; body weight loss was observed in both groups. Histologic alterations observed at this exposure level included nasal and ocular inflammation and discharge, bronchitis, and catarrhus lesions of the alveoli with peribronchiolar infiltrations (more pronounced in the four times/day group). The alveolar lesions were reversible; 15 days after exposure termination, the lung histology was similar to that of controls. No histologic alterations were observed in the liver. At 10 ppm, alveolar irritation and decreases in body weight gain were observed. No adverse effects on clinical signs, body weight gain, or histopathology of the lungs were observed at 5 ppm. Exposure to chlorine dioxide did not adversely affect hematologic parameters. This study identifies a NOAEL of 5 ppm (14 mg/m<sup>3</sup>) and LOAEL of 10 ppm (28 mg/m<sup>3</sup>) for lung damage following intermittent exposure for 15-minute periods, two or four times/day for 4 weeks.

Dalhamn (1957) conducted a series of inhalation studies to assess toxicity of chlorine dioxide in the rat (sex and strain not reported). In the first study, a group of three rats was exposed once a week for 3 minutes to decreasing concentrations of chlorine dioxide (3,400 ppm [9,500 mg/m<sup>3</sup>] in week 1, 1,100 ppm [3,000 mg/m<sup>3</sup>] in week 2, and 800 ppm [2,200 mg/m<sup>3</sup>] in week 3); a second group of three rats served as controls. Respiratory distress and decreased body weight were observed in the chlorine dioxide-exposed rats. Bronchopneumonia and hyperemia of the renal corticomedullary junction were observed in two of three rats; the renal hyperemia was also observed in the control group (2/3). In the second study, exposure to 260 ppm (720 mg/m<sup>3</sup>) chlorine dioxide for 2 hours resulted in ocular discharge, epistaxis, death (1/4 rats), pulmonary edema, and circulatory engorgement. In the third study, groups of five rats were exposed to 0 or approximately 10 ppm chlorine dioxide (28 mg/m<sup>3</sup>) 4 hours/day for 9 days in a 13-day period. Death (3/5 rats), rhinorrhea, “embarrassed respiration,” and weight loss were observed in the chlorine dioxide-exposed rats. Respiratory infection with acute renal and hepatic congestion also were observed. The fourth study involved exposure of groups of five rats to 0 or approximately 0.1 ppm chlorine dioxide (0.28 mg/m<sup>3</sup>) 5 hours/day for 10 weeks (frequency of exposure not reported). No effects on body weight gain were observed and no histologic alterations were observed in the lungs, kidneys, or liver. The Dalhamn studies identified a NOAEL of 0.1 ppm (0.28 mg/m<sup>3</sup>) in rats exposed 5 hours/day for 10 weeks and a LOAEL of 10 ppm (28 mg/m<sup>3</sup>) for respiratory tract irritation in rats exposed 4 hours/day for approximately 2 weeks.

#### **4.2.2.2. Chlorite**

No animal inhalation or intratracheal installation data were located for chlorite.

### **4.3. REPRODUCTIVE/DEVELOPMENTAL STUDIES—ORAL AND INHALATION**

#### **4.3.1. Chlorine Dioxide**

Carlton et al. (1991) administered daily gavage doses of 0, 2.5, 5, or 10 mg/kg chlorine dioxide in deionized water to groups of 12 male Long-Evans rats for 56 days prior to mating and throughout the 10-day mating period. Groups of 24 female rats received the same gavage doses for 14 days prior to mating, during the mating period, and throughout gestation and lactation. No significant alterations in mortality, clinical signs, fertility rates, sperm parameters, length of gestation, prenatal deaths, mean litter size, or mean pup weights were observed. A statistically significant delay in the day of eye opening was observed in pups from the 10 mg/kg-day group, but the study authors did not consider this effect to be biologically significant because it was not dose related (16.70, 15.59, 16.26, and 15.95 days in the 0, 2.5, 5, and 10 mg/kg-day groups, respectively). No significant alterations in reproductive tract organ weights were observed in the F1 male rats. In the F1 female rats, there were statistically significant decreases in absolute and relative vagina weights in the 10 mg/kg-day group, but no differences in terminal body weights or uterine and ovarian weights. No consistent chlorine dioxide-related alterations in T3 or T4 levels were measured in the F0 male and female rats and F1 male rats (hormone levels measured on postnatal days 17, 28, and 40). This study identifies a NOAEL of 10 mg/kg-day for reproductive effects in rats receiving gavage doses of chlorine dioxide.

In a developmental toxicity study by Suh et al. (1983), groups of six to eight female Sprague-Dawley rats were administered 0, 1, 10, or 100 mg/L chlorine dioxide in the drinking water (0, 0.1, 1, and 10 mg/kg-day using a reference body weight of 0.35 kg and water intake of 0.046 L/day) for 2.5 months prior to mating with unexposed males and during gestational days 0–20; the dams were killed on gestational day 20. A slight, nonsignificant decrease in maternal body weight gain was observed in the 10 and 100 mg/L groups. There was a statistically significant trend for decreasing number of implants per litter and number of live fetuses per dam. Total fetal weights and male fetal weights were significantly increased in the 100 mg/L group compared with controls; crown-rump length was not significantly affected. Incidences of skeletal anomalies did not significantly differ between groups. This study identifies a NOAEL of 10 mg/L (1 mg/kg-day) and LOAEL of 100 ppm (10 mg/kg-day) for developmental effects in the offspring of rats exposed to chlorine dioxide in the drinking water.

Toth et al. (1990) examined the neurodevelopmental toxicity of chlorine dioxide in the postnatally exposed Long-Evans hooded rats. Groups of four male and four female pups per litter received daily gavage doses of 0 or 14 mg/kg chlorine dioxide on postnatal days 1–20. The chlorine dioxide pups weighed significantly less than controls at ages 11, 21, and 35 days. No significant alterations in cerebellum or olfactory bulb weights were observed on postnatal days 11, 21, or 35. Forebrain weights were significantly lower in the chlorine dioxide-exposed pups on postnatal days 21 and 35. This reduction in forebrain weight was accompanied by reductions

in protein content on postnatal days 21 and 35 and reduced DNA content on postnatal day 35. The ratio of protein content to forebrain weight was decreased on postnatal days 11, 21, and 35; the protein content to cerebellum weight was increased on postnatal day 35. The ratio of DNA content to brain part weight was not significantly affected in the chlorine dioxide-exposed pups. No alterations in counts of branches of apical dendrites of cerebral cortical layer 5 pyramidal cells were observed, but dendritic spine counts in the Krieg's area 18 (a visual association region of the cortex) were significantly decreased. No gross lesions, loss of myelin, or changes in cells staining positive for Nissl substance in the forebrain, cerebellum, or brainstem were observed in the brains of chlorine dioxide-exposed pups. No significant alterations in T3 or T4 levels or free T4 index were observed on postnatal days 11, 21, and 35. This study identifies a LOAEL of 14 mg/kg-day for altered brain development (decreased forebrain weight and protein content) in postnatally exposed rats.

Mobley et al. (1990) exposed groups of 12 female Sprague-Dawley rats to 0 or 100 ppm chlorine dioxide in the drinking water (0 or 14 mg/kg-day using a reference body weight of 0.35 kg and water intake of 0.046 L/day) for 10 days prior to mating with unexposed males and during the gestation and lactation periods (until postconception days 35–42). No significant alterations in litter size were observed. At birth, the litter weight of the chlorine dioxide-exposed group was significantly lower than that of controls. Chlorine dioxide exposure significantly decreased exploratory activity on postconception days 36–39, but not on days 39–41. Although serum T3 and T4 levels were not significantly altered in the chlorine dioxide-exposed pups (assessed on postconception days 37 and 38), a significant decrease in T3 uptake was observed. Free T3 and T4 levels were lower in the chlorine dioxide group, but the difference was not statistically significant. On postconception day 42, there were no significant alterations in total T3 or T4, free T4, or T3 uptake. The day of eye opening was not significantly affected by chlorine dioxide exposure. Thus, 100 ppm (14 mg/kg-day) is a LOAEL for decreased litter weight and exploratory activity.

In a study conducted by Orme et al. (1985) designed to assess toxicity of chlorine dioxide on the thyroid, groups of female Sprague-Dawley rats were exposed to 0, 2, 20, or 100 mg/L in the drinking water (doses of 0, 1, 3, and 14 mg/kg-day were estimated by U.S. EPA, 1994d) for 2 weeks prior to mating and throughout gestation and lactation. In a companion study, groups of 5-day-old Sprague-Dawley pups (dams were not exposed) received gavage doses of 0 or 14 mg/kg-day chlorine dioxide on postnatal days 5–20. No significant alterations in pup weight were observed in the pups exposed in utero; the postnatally exposed pups weighed significantly less than controls on postnatal days 14–21. Age of eye opening was not affected by chlorine dioxide exposure. Locomotor activity was consistently decreased in the 100 mg/L group, but the decrease was not statistically significant. In the 14 mg/kg-day gavaged group, activity was significantly decreased on postnatal days 18–19; on days 15–17 and 20, activity levels were similar to controls. In the 100 mg/L group, there was a significant decrease in T3 and T4 levels; T4 levels were also significantly decreased in the 14 mg/kg-day group. In all groups, there was a significant correlation between T4 levels and locomotor activity. T4 levels were not significantly altered in the chlorine dioxide-exposed dams. This study identifies a NOAEL of 20 mg/L (3 mg/kg-day) and a LOAEL of 100 mg/L (14 mg/kg-day) for neurobehavioral effects (decreased

T3 and T4 levels and delayed development) in the offspring of rats exposed to chlorine dioxide in drinking water.

Taylor and Pfohl (1985) exposed groups of 13–16 female Sprague-Dawley rats to 0 or 100 ppm chlorine dioxide in drinking water (0 or 14 mg/kg-day calculated using a reference body weight of 0.35 kg and water intake of 0.046 L/day) for 14 days prior to breeding and throughout gestation and lactation. Groups of male pups from unexposed dams were administered 0 or 14 mg/kg chlorine dioxide via gavage from postnatal days 5 to 20. No significant alterations in maternal or pup body weights were observed in the group receiving 100 ppm in the drinking water. A significant decrease in whole brain weight, primarily because of a decrease in cerebellar weight, was observed in the 21-day-old offspring of dams receiving 100 ppm in the drinking water. A decrease in cerebellar total DNA content also was observed; the difference was caused by a decrease in total number of cells rather than in cell density. A nonsignificant decrease in locomotor activity (assessed at 10–20 days of age) was observed in the 100 ppm offspring. A significant decrease in exploratory behavior was observed in the 100 ppm offspring at 60 days of age. In the pups receiving gavage doses of chlorine dioxide, significant decreases in body weight, absolute and relative whole brain and forebrain weights, and forebrain DNA content and total cell number were observed in the 21-day-old pups; cerebellum and forebrain DNA content and total cell number were also significantly decreased in the 11-day-old pups. Significant decreases in home cage and wheel-running activity at ages 18–19 and 10 days, respectively, also were observed in the pups receiving gavage doses of chlorine dioxide. Thus, the LOAEL for neurobehavioral effects, decreased brain weight, and cell number in the offspring of rats exposed to chlorine dioxide in drinking water and in rats postnatally exposed to chlorine dioxide via gavage is 14 mg/kg-day.

#### **4.3.2. Chlorite**

The Chemical Manufacturers Association (CMA) conducted a two-generation study to examine reproductive, developmental neurotoxicity, and hematologic endpoints in rats exposed to sodium chlorite (CMA, 1996). Thirty male and 30 female Sprague-Dawley rats of the OFA(SD)IOPS-Caw strain (F0) generation received drinking water containing 35, 70, or 300 ppm sodium chlorite (concentrations of sodium chlorite in the drinking water were apparently adjusted to compensate for the 81.4% purity of the test material) for 10 weeks and were then paired (1M:1F) for mating. A similar group received purified water and served as controls. Males were exposed throughout mating and then were sacrificed. Exposure for the females continued through mating, pregnancy, and lactation until necropsy following weaning of their litters. Sodium chlorite concentrations were adjusted downward during lactation to offset increases in the volume of water consumed so that a constant intake (mg/kg-day) could be maintained. Twenty-five males and females from each of the first 25 litters to be weaned in a treatment group were chosen to produce the F1 generation. The F1 pups were continued on the same treatment regimen as their parents. At approximately 14 weeks of age, they were mated to produce the F2a generation. Because of a reduced number of litters in the 70 ppm F1-F2a generation, the F1 animals were remated following weaning of the F2a to produce the F2b generation. Pregnant F1 females were allowed to litter and rear the F2a and F2b generations until weaning at postnatal day 21. Based on sodium chlorite intake (in mg/kg-day) calculated by

the study authors from measured water consumption and body weight, and adjusting for the molecular weight of sodium in sodium chlorite, doses for the F0 animals were 0, 3, 5.6, and 20 and 0, 3.8, 7.5, and 28.6 mg/kg-day chlorite for males and females, respectively. For the F1 animals, doses were 0, 2.9, 5.9, and 22.7 mg/kg-day chlorite for the males and 0, 3.8, 7.9, and 28.6 mg/kg-day chlorite for the females. Numerous parameters were measured or calculated, including body weight, food and water consumption, estrus cycle in the F0 and F1 rats, and hematology and T3 and T4 levels in the F1 rats (blood samples collected from 1 male and 1 female from the first 20 F1 litters at age 25 days and another group at 13 weeks). Other parameters measured were gestation duration, litter size, pup sex, pup body weight, pup developmental landmarks, number alive/dead pups in the F1 and F2 generations, total caudal sperm number and percent motile, morphology by computer-assisted sperm motility analysis in the F0 and F1 rats, and organ weight and histopathologic examination of the brain, pituitary gland, liver, adrenal gland, spleen, thymus, kidneys, and reproductive organs of all F0 and F1 controls and high-dose animals. An additional group of F1 pups was chosen for neurohistopathology on postnatal day 11 (examination of the brain and spinal cord) or postnatal day 60 (sensory ganglia, dorsal and ventral nerve roots, and several peripheral nerves and muscles). Another group of F1 rats was examined for neurotoxicological endpoints (motor activity in a "Figure 8" Activity System and neuropathology on postnatal day 60, auditory startle in the SR-Screening System, learning and memory retention in a water E-maze). A functional observational battery (FOB) was also conducted on the pups undergoing auditory and learning assessments. This group was composed of 2 males and 2 females from 20 litters, and exposure was discontinued after weaning. Reevaluation of the auditory startle response was conducted in 20 males and 20 females in the F2a and F2b generations.

There were reductions in water consumption, food consumption, and body weight gain in both sexes in all generations at various times throughout the experiment (e.g., during pre mating, pregnancy, gestation, postweaning), primarily in the 70 and 300 ppm groups. The authors attributed these reductions to lack of palatability of the drinking water solution, but did not show data to support this contention. Significant alterations related to treatment at 300 ppm include reduced absolute and relative liver weight in F0 females and F1 males and females, reduced pup survival (increase in number of pups found dead and/or killed prematurely during lactation) and reduced body weight at birth and throughout lactation in F1 and F2 rats, lower thymus and spleen weight in both generations, lowered incidence of pups exhibiting normal righting reflex and with eyes open on postnatal day 15, alteration in clinical condition in F2 animals chosen for neurotoxicity, decrease in absolute brain weight for F1 males and F2 females, delay in sexual development in males (preputial separation) and females (vaginal opening) in F1 and F2 rats, and lower red blood cell parameters in F1 rats. The reported alterations in pup sexual maturation measures might be due to reduced pup body weight, but a definitive conclusion cannot be drawn. In the 70 ppm groups, reduced absolute and relative liver weight in F0 females and F1 males was observed. Minor, statistically significant changes in hematologic data at the 35 and 70 ppm concentrations (generally 1%–7%) in the F1 rats appear to be within normal ranges based on historical data and are therefore not considered clinically or biologically significant or adverse. In addition, a significant decrease in maximum response to an auditory startle stimulus was noted in the 70 and 300 ppm groups on postnatal day 24, but not on postnatal day 60. Analysis of the

E-maze data by EPA personnel indicated possible alterations in learning behavior in the 70 ppm group, but the differences from the conclusions of the report could not be resolved.

The CMA (1996) study is adequate in that it was conducted with sufficient numbers of animals of both sexes and examined numerous endpoints. The study is acceptable and consistent with EPA testing guidelines that were in effect at the time of the study (U.S. EPA, 1991). However, there are several limitations to this study. Lack of pair-watered and pair-fed control animals confounds the results and precludes definitive conclusions as to whether the alterations in food and water consumption and body weight are related to water palatability or a direct toxic effect of the agent. Developmental landmarks (e.g., vaginal opening in F2a group) were not reported for all groups. Grip strength and landing foot splay were not included in the FOB. Discontinuation of exposure for the animals undergoing neurotoxicity testing minimizes the likelihood of finding a positive effect and precludes comparison of the data with those of other rats with continued exposure. Although the study employed an exposure regimen consistent with testing guidelines and should potentially detect adverse effects on the developing nervous system, discontinuation of exposure after weaning reduces the opportunity to detect neurological effects from continuous or lifetime exposures similar to those expected from lifetime drinking water exposure in humans.

Interpretation of the neurobehavioral tests is limited. The report lacks detailed descriptions of experimental methods (e.g., size of the arena, length of observations) and positive control data (including estimates of variability) for the FOB. Positive control studies for the motor activity and E-maze studies used high doses of the validation chemicals, were not adequate to show the sensitivity of the methods, and showed only that effects of the chemicals at maximally toxic doses could be recognized. Variability in the startle response data was high. The high variability and problems in calibrating and operating the automated startle apparatus (as presented in the report) would tend to decrease the sensitivity of the test to detect a difference between control and treated groups, because differences in startle amplitude would have to be larger to attain statistical significance. In some cases, inappropriate statistical analyses were applied. For example, repeated-measures techniques were apparently not used to account for the fact that the rats were tested repeatedly, and it is not clear how nonparametric rank data were analyzed or why a log transformation was applied to the learning data. The NOAEL for this study is 35 ppm (2.9 mg/kg-day chlorite) and the LOAEL is 70 ppm (5.9 mg/kg-day chlorite) based on lowered auditory startle amplitude and altered liver weights in two generations.

Groups of 12 male Long-Evans rats were exposed to 0, 1, 10, or 100 ppm sodium chlorite (0, 0.7, 7, and 70 ppm chlorite) in the drinking water for 56 days prior to mating and throughout a 10-day mating period (Carlton and Smith, 1985; Carlton et al., 1985, 1987). Groups of 24 female rats were exposed to the same sodium chlorite drinking water concentrations for 14 days prior to mating, during the mating period, and throughout gestation and lactation. Doses of 0, 0.075, 0.75, and 7.5 mg/kg-day were estimated by EPA (1994d). No significant alterations in body weight gain or water consumption were observed. There was a wide degree of variability among fertility rates for the different groups (67%–96%), but no dose-related alterations in fertility rates were observed. No significant alterations in litter survival rates, median day of eye opening, or median day of observed vaginal patency were observed. Additionally, no alterations

were observed in gross and histopathologic examination of reproductive tract tissues, hematologic parameters, or testis, epididymis, and caudal epididymis weights. No significant alterations in sperm count or percentage of sperm mobility were observed. A trend toward decreased sperm mean progressive movement was observed in the 100 ppm group, but the velocity was not significantly different from controls. The percentage of abnormal sperm in sodium chlorite-exposed rats did not differ from controls. No significant alterations in T3 and T4 hormone levels were observed in the F0 males or females. T3 and T4 levels were measured in the F1 males and females on postnatal days 17 (males only), 21, and 40; significant decreases in hormone levels were consistently observed at 100 ppm at days 21 and 40. This study identifies a NOAEL of 10 ppm (0.75 mg/kg-day) and a LOAEL of 100 ppm (7.5 mg/kg-day) for altered thyroid hormone levels in the offspring of rats exposed to sodium chlorite in drinking water.

Carlton and Smith (1985) and Carlton et al. (1985, 1987) conducted two follow-up studies to further investigate the effect of sodium chlorite on sperm parameters. In these studies, groups of 12 male rats received drinking water containing 0, 100, or 500 ppm sodium chlorite (0, 70, and 370 ppm chlorite) or 0, 1, 10, or 100 ppm sodium chlorite (0, 0.7, 7, and 70 ppm chlorite) for 72–76 days. Water consumption was significantly decreased (28%) in the 500 ppm group; in other groups, water consumption was similar to that of controls. Estimated doses of 0.075, 0.75, 7.5, and 27 mg/kg-day were calculated for the 1, 10, 100, and 500 ppm groups, respectively. No significant alterations in body weight gain were observed in the sodium chlorite-exposed rats. As in the first experiment, there were no significant alterations in sperm count, percentage of sperm mobility, or mean progressive movement. However, there was a trend toward decreased progressive movement in the 100 and 500 ppm groups. When the three experiments were combined, there was a statistically significant reduction of direct progressive movement at 100 and 500 ppm. A significant increase in abnormal sperm was observed in the 100 and 500 ppm groups; the most common morphological abnormalities were frayed tails, open hooks, and amorphous sperm heads. Collectively, these studies identify a NOAEL of 10 ppm (0.75 mg/kg-day) and LOAEL of 100 ppm (7.5 mg/kg-day) for reproductive effects in rats exposed to sodium chlorite in drinking water.

Couri et al. (1982) exposed groups of 7–13 pregnant Sprague-Dawley rats to 0%, 0.1%, 0.5%, or 2% sodium chlorite (0%, 0.07%, 0.4%, and 1.5% chlorite) in the drinking water during gestational days 8–15. The litters were either delivered at term or by cesarean section on gestational day 22. Using the daily doses of 0, 34, 163, and 212 mg sodium chlorite/rat/day calculated by the study authors and an estimated body weight (midpoint of gestation day 1 body weights [0.280 kg] plus one-half of the body weight gain), doses of 0, 95, 590, and 820 mg/kg-day sodium chlorite (0, 70, 440, and 610 mg/kg-day chlorite) were calculated. Another group of four pregnant rats received daily gavage doses of 200 mg/kg sodium chlorite on gestational days 8–15. Profuse vaginal and urethral bleeding and 100% mortality were observed in the rats receiving 200 mg/kg gavage doses. No deaths were observed in the rats receiving sodium chlorite via drinking water. Weight loss and decreases in food and water consumption were observed at the 0.5% and 2% concentrations; decreased water consumption was also observed in the 0.1% group. Irregular blood cells, ruptured cells, and hemolysis were observed in the 2% and 200 mg/kg-day groups. Significant decreases in crown-rump length were observed in litters

term-delivered in the 0.1%, 0.5%, and 2% groups and in the 0.5% group cesarean-delivered on gestational day 22. Fetal weights were not adversely affected. An increase in the number of resorbed and dead fetuses was observed in litters delivered on gestational day 22 in the 0.1%, 0.5%, and 2% groups; two litters out of five were totally resorbed in the 2% group. Postnatal growth and the incidences of soft tissue and skeletal malformations were not adversely affected by in utero exposure to sodium chlorite. This study identifies a FEL of 0.1% for resorbed and dead fetuses and decreases in crown-rump length in the offspring of rats exposed to 0.1% sodium chlorite (70 mg/kg-day chlorite) in drinking water.

Groups of six to nine female Sprague-Dawley rats were administered 0, 1, or 10 mg/L chlorite in the drinking water (0, 0.1, or 1 mg/kg-day calculated using a reference body weight of 0.35 kg and water intake of 0.046 L/day) for 2.5 months prior to mating with unexposed males and during gestational days 0–20; the dams were killed on gestational day 20 (Suh et al., 1983). No significant alterations in general appearance or maternal body weight gain were observed. No significant alterations in number of implants (total and per dam), resorptions, or dead fetuses were observed. No difference in fetal body weights was observed. Crown-rump length was significantly higher in the 10 mg/L group compared with controls, but the difference was very small and is probably not biologically significant. Chlorite exposure did not significantly alter incidence of skeletal anomalies. This study identifies a NOAEL of 10 mg/L (1 mg/kg-day) for developmental toxicity in the offspring of rats exposed to chlorite in the drinking water.

Mobley et al. (1990) exposed groups of 12 female Sprague-Dawley rats to 0, 20, or 40 ppm chlorite in the drinking water (doses of 0, 3, and 6 mg/kg-day were estimated by U.S. EPA, 1994d) for 10 days prior to mating with unexposed males and during gestation and lactation until postnatal days 42–53. Chlorite exposure did not adversely affect litter size or pup weight gain. Significant, consistent decreases in exploratory activity were observed in the 40 ppm group on postnatal days 36–39, but not on days 39–41. In the 20 ppm group, there were significant decreases in activity on days 36 and 37, but not on days 38–40. No significant alterations in serum T3 or T4 levels were observed in the 37–38- or 42-day-old postconception pups. However, the free T4 levels were significantly increased in the 40 ppm group. The day of eye opening in the 20 and 40 ppm groups was similar to that of controls. A review of the results of this study relative to the findings of the newer developmental studies in the database suggests that the NOAEL for neurodevelopmental behavioral effects in rats exposed to chlorite in drinking water for this study is 20 ppm (3 mg/kg-day) and the LOAEL is 40 ppm (6 mg/kg-day).

Moore et al. (1980) (data also presented in Moore and Calabrese, 1982) exposed groups of pregnant female A/J mice to 0 or 100 ppm sodium chlorite in drinking water throughout gestation and lactation; 21 control and 12 exposed dams had litters. EPA (1994d) estimated that the 100 ppm sodium chlorite (75 ppm chlorite) concentration corresponds to a dose of 22 mg/kg-day. A decrease in the conception rate (number of females positive for vaginal plug/number of females producing litters) was observed in the chlorite group (39% vs. 56% in controls); the statistical significance was not reported. No statistically significant alterations in gestation length, litter size, number of pups dead at birth, and number of pups alive at weaning were observed. Pup growth was adversely affected, as shown by significant decreases in average pup weaning weight and birth to weaning growth rate. This study identifies a LOAEL of 100 ppm



(22 mg/kg-day) for developmental effects in the offspring of mice exposed to chlorite in the drinking water.

Harrington et al. (1995b) treated groups of 16 female New Zealand white rabbits with technical-grade sodium chlorite (80.6% purity) via their drinking water at levels of 0, 200, 600, or 1,200 ppm from gestation days 7–20, followed by terminal sacrifice at day 28. Water concentrations were maintained at the same levels throughout pregnancy and were not adjusted for changes in volume of water consumed. Based on measured water consumption, the study authors calculated a mean daily intake of approximately 0, 10, 26, or 40 mg/kg-day chlorite (corrected for purity and adjusted by the weight of the salt). Clinical condition, maternal body weight, and food and water consumption were measured daily. At necropsy, gravid uterine weights, number of corpora lutea, number of implantation sites, and live and dead fetuses were recorded. Live fetuses were weighed, examined for external abnormalities, sexed, and dissected, and a gross visceral examination was performed. Skeletal examinations were also performed. Abnormalities were categorized as minor or major, and the latter were thought to impair survival or fitness. Commonly observed variations were also recorded. The study authors did not state which malformations fell into each of these categories. There was no mortality, although two rabbits (one from each of the control and 26 mg/kg-day groups) were sacrificed in extremis because of a clinical condition unrelated to treatment. A significant decrease in water consumption during the treatment period was observed in the 26 and 40 mg/kg-day groups, and a decrease during treatment days 16–20 of pregnancy was observed in the 10 mg/kg-day group. The study authors attributed the decreases in consumption to lack of palatability of the drinking water solution, although no supporting data were presented. Food consumption was decreased in the 26 and 40 mg/kg-day groups during days 7–11 of pregnancy. Body weight gain of treated animals was decreased on days 7–19, although by day 26 these groups showed no differences from controls in body weight gain.

The authors concluded there were no treatment-related effects on pregnancy incidence, number of implantations, number of preimplantation losses, fetal sex ratio, number of live fetuses, or fetal visceral or structural abnormalities. Data for specific malformations and variations were not shown; instead, data were presented as the number or mean percentage of fetuses with major or minor external and visceral or skeletal abnormalities. The number and mean percentage of major external and visceral and skeletal abnormalities were increased in the 26 and 40 mg/kg-day groups (external/visceral: 6.6% and 2.9%, respectively, vs. 1.5% in controls; skeletal: 5.4% and 0%, respectively, vs. 0% in controls). Mean fetal weights in the 26 and 40 mg/kg-day groups were slightly decreased (< 9% relative to controls). In the 26 and 40 mg/kg-day groups, the incidence of minor skeletal abnormalities (13.9 and 14.2 for the 26 and 40 mg/kg-day groups, respectively, vs. 7.7% in controls) and skeletal variants related to incomplete fetal bone ossification (such as of the pubis and sternbrae) was higher than for controls. The authors state in their discussion that these alterations in fetal body weight and delayed ossification indicate embryonic growth retardation. The NOAEL for this study is 200 ppm (10 mg/kg-day chlorite) and the LOAEL is 600 ppm (26 mg/kg-day chlorite) based on decreased fetal weight and delayed skeletal ossification, decreased food and water consumption in the dams, and decreased body weight gain in the dams. Although this study employed sufficient numbers of animals and administered chlorite by a route relevant to human exposure, uncertainties exist in

interpretation of the results because of inadequate reporting of the number and types of specific abnormalities and variations. There is additional uncertainty as to whether the decreases in food and water consumption and body weight gain in the dams are caused by unpalatability or a direct toxic effect of the chlorite.

#### **4.4. OTHER STUDIES**

##### **4.4.1. Other Carcinogenicity Studies**

###### **4.4.1.1. Chlorine Dioxide**

The potential for chlorine dioxide to induce proliferative epidermal hyperplasia was examined by Robinson et al. (1986). Groups of five dorsally shaved female SENCAR mice were placed in chambers filled with 0, 1, 10, 100, 300, or 1,000 ppm liquid chlorine dioxide; the chambers were designed to prevent the head from getting wet and to prevent inhalation of vapors. The animals were exposed 10 minutes/day for 4 days. A significant increase in interfollicular epidermal thickness was observed in the 1,000 ppm group, but not at the lower concentrations. Increases in total cell numbers and basal cell numbers in skin sections were observed in both the 300 and 1,000 ppm groups. In a second study, groups of 40 mice were immersed in 0 or 1,000 ppm chlorine dioxide for 10 minutes; animals (5/group) were killed 1, 2, 3, 4, 5, 8, 10, or 12 days postexposure. A significant increase in interfollicular epidermis thickness was observed at all time periods, with the highest values at 10 and 12 days postexposure. The authors concluded that even short-term dermal exposure to high concentrations of chlorine dioxide is capable of inducing hyperplastic responses in the mouse skin.

Miller et al. (1986) tested the carcinogenic potential of drinking water disinfected with chlorine dioxide using three short-term assays. Following disinfection with chlorine dioxide, the water samples (containing 0.5 mg/L chlorine dioxide residue) were concentrated 2,000× or 4,000× using a macroreticular resin process. In a mouse initiation-promotion assay, groups of 14–34 SENCAR mice (sex not specified) were orally administered 0.5 mL of the 4000× concentrate in 2% emulphor 3 times/week for 2 weeks followed by topical exposure to 1.0 : g 12-tetradecanylphorbol-13-acetate (TPA) in acetone applied to the dorsal skin 3 times/week for 20 weeks and then sacrificed. No significant increases, compared with vehicle controls, in the number of skin tumors or the number of tumors per animal were observed.

In a lung adenoma assay (Miller et al., 1986), groups of 20 male and 20 female Strain A mice received 0.25 mL gavage doses of 2000× or 4000× concentrates in 2% emulphor 3 times/week for 8 weeks followed by a 16-week observation period. The number of animals with lung adenomas and the number of adenomas per animal were not significantly altered compared with vehicle controls.

Miller et al. (1986) also examined the development of liver foci in rats in a short-term assay. In this study, groups of partially hepatectomized rats received a single dose of concentrated water (chlorine dioxide concentration not reported) in 2% emulphor followed 1 week later by administration of 500 ppm sodium phenobarbital in drinking water for 56 days;

animals were sacrificed on day 70. A control group received nondisinfected water. No significant increases in incidence of  $\gamma$ -glutamyltranspeptidase foci were observed.

#### **4.4.1.2. Chlorite**

Kurokawa et al. (1984) also conducted dermal carcinogenicity studies. In a study to assess the ability of chlorite to act as a complete carcinogen, groups of 20 female SENCAR mice were exposed twice weekly for 51 weeks to 20 mg/mL sodium chlorite in acetone. The solution (0.2 mL; 100 mg/kg sodium chlorite per application) was applied to the shaved backs of the mice. The sodium chlorite exposure did not result in increased tumor incidence. To test the ability of chlorite to act as a tumor promoter, a single initiating dose of 20  $\mu$ mol of dimethylbenzanthracene (DMBA) was applied to the skin of 20 SENCAR mice. The DMBA application was followed by a 51-week exposure to sodium chlorite (as described for the complete carcinogen study). Tumor incidence was 6/20 (30%) compared with 0/20 in mice that received DMBA followed by acetone treatments for 51 weeks. Squamous cell carcinomas were observed in 5/20 animals in the chlorite group. However, the results were not statistically significant.

#### **4.4.2. Genotoxicity Studies**

##### **4.4.2.1. Chlorine Dioxide**

Both positive and negative results have been found in in vitro genotoxicity studies. Chlorine dioxide did not increase chromosome aberrations in Chinese hamster fibroblast cells but did increase reverse mutation in *Salmonella typhimurium* (with activation) (Ishidate et al., 1984). However, water samples disinfected with chlorine dioxide did not induce reverse mutations in *S. typhimurium* with or without activation (Miller et al., 1986). In vivo micronucleus and bone marrow chromosomal aberration assays in Swiss CD-1 mice administered 0.1–0.4 mg chlorine dioxide via gavage for 5 consecutive days were negative, as was a sperm-head abnormality assay in B6C3F1 mice administered 0.1–0.4 mg via gavage for 5 consecutive days (0, 3.2, 8, and 16 mg/kg-day) (Meier et al., 1985). Hayashi et al. (1988) reported positive results in the micronucleus assay in ddY mice following a single intraperitoneal injection of 3.2–25 mg/kg chlorine dioxide.

##### **4.4.2.2. Chlorite**

Genotoxicity of chlorite was assessed in several in vitro and in vivo assays. In in vitro assays, chlorite induced reverse mutations in *S. typhimurium* (with activation) and chromosome aberrations in Chinese hamster fibroblast cells (Ishidate et al., 1984). In general, the results of the in vivo assays were negative. In the micronucleus assays, negative results were found in ddY mice following an oral gavage dose of 37.5–300 mg/kg chlorite single injection (Hayashi et al., 1988) and in Swiss CD-1 mice administered 0.25–1 mg chlorite via gavage for 5 consecutive days (0, 8, 20, and 40 mg/kg-day) (Meier et al., 1985). Using the same dosages, Meier et al. also reported negative results in the bone marrow chromosomal aberration assay in Swiss CD-1 mice and in the sperm-head abnormality assay in B6C3F1 mice. Positive results were found in the

micronucleus assay in ddY mice when the chlorite was administered via intraperitoneal injection (7.5–60 mg/kg) (Hayashi et al., 1988).

#### **4.4.3. Mechanistic Studies**

EPA (1994d) has extensively discussed the mechanism of action whereby chlorine dioxide and chlorite produce hematologic and systemic effects. The mechanisms are still incompletely understood. Oxidative damage to the erythrocyte and production of methemoglobin are most likely related to their properties as oxidants (U.S. EPA, 1994d). Chlorite is thought to be the intermediate species responsible in many of the hematologic effects of chlorine dioxide because of its more efficient production of methemoglobin, depletion of red blood cell (RBC) glutathione, and alteration of erythrocyte fragility.

In a series of experiments, Bercz and co-workers (1982, 1986); and Harrington et al. (1986) suggested that chlorine dioxide increases binding of dietary iodide to gastrointestinal tissue and contents, producing a functional iodide deficiency. Bercz et al. (1982) found decreased levels of circulating thyroxine in monkeys drinking water containing > 9.5 mg/kg-day chlorine dioxide, but not 44 mg/kg-day chlorite, for 4–6 weeks. In a follow-up study, Harrington et al. (1986) demonstrated increases in thyroid iodide uptake and a rebound in thyroxine levels in monkeys 1 year after an 8-week exposure to approximately 5 mg/kg-day chlorine dioxide in drinking water. Unlike monkeys, rats showed dose-related declines in thyroxine levels and no alteration in thyroid iodide uptake following an 8-week exposure to 10 mg/kg-day chlorine dioxide in drinking water.

Whether either or both of these mechanisms are operable in inducing reproductive, developmental, and neurodevelopmental effects is not known. One could also speculate that hypothyroidism, induced by chlorine dioxide alteration of iodide uptake in the gastrointestinal tract, might contribute to alterations in maternal or neonatal behavior. Alternative, as yet unknown mechanisms are also plausible because few definitive mechanistic data are available. Additional research is needed to understand whether the parent chlorine dioxide and/or its oxychlorine degradation products induce delays and alterations in fetal/neonatal neurodevelopment and behavior through disturbance in maternal thyroid function or directly within the embryo itself.

### **4.5. SYNTHESIS AND EVALUATION OF MAJOR NONCANCER EFFECTS AND MODE OF ACTION (IF KNOWN)—ORAL AND INHALATION**

#### **4.5.1. Oral Exposure**

##### **4.5.1.1. Chlorine Dioxide**

The subchronic/chronic toxicity of chlorine dioxide has not been adequately assessed. The Haag (1949) chronic drinking water study reported decreases in survival in rats exposed to 13 mg/kg-day chlorine dioxide for 2 years, but the cause of death was not reported and no effects were observed at lower concentrations. The small number of animals tested and the limited

number and lack of sensitive endpoints examined make interpretation of this study difficult. Daniel et al. (1990) found increases in incidence of nasal lesions in rats exposed to \$ 25 mg/L chlorine dioxide (2 mg/kg-day) in drinking water for 90 days; no other adverse effects were observed. However, it is not known if the nasal lesions resulted from inhaling chlorine dioxide vapors at the drinking water sipper tube or from off-gassing of the vapors after drinking. No other studies have reported similar effects. Other subchronic/chronic studies primarily examined hematologic parameters. Bercz et al. (1982) found significant decreases in serum T4 levels in monkeys exposed to 9.5 mg/kg-day chlorine dioxide in the drinking water for 4–6 weeks. Adverse hematologic effects could not be discerned in Abdel-Rahman et al. (1984b) because there was no consistent dose-effect relationship. Additionally, Daniel et al. (1990), Bercz et al. (1982), and Moore and Calabrese (1982) did not find hematologic alterations in rats, monkeys, or mice, respectively. Abdel-Rahman et al. (1984b) and Couri and Abdel-Rahman (1980) reported alterations in the glutathione-dependent system, in particular, decreases in erythrocyte glutathione levels, increases in glutathione peroxidase activity, and increases in erythrocyte catalase levels. However, as with the hematologic effects this group found, consistent relationships between dose and magnitude of the alterations were lacking.

A number of studies have consistently found developmental effects following in utero exposure or postnatal gavage administration of 14 mg/kg-day chlorine dioxide. The effects include altered brain development (decreases in forebrain and/or cerebellum DNA content, ratio of protein content to forebrain weight, and dendritic spine counts in a visual association area of the cerebral cortex) (Toth et al., 1990; Taylor and Pfohl, 1985), decreased locomotor or exploratory activity (Orme et al., 1985; Taylor and Pfohl, 1985), and increased T3 uptake (Moblely et al., 1990). Orme et al. (1985) found decreases in T3 and T4 levels in in utero and postnatally exposed pups; however, other studies did not find alterations in T3 and T4 levels in similarly exposed animals (Toth et al., 1990; Carlton et al., 1991).

The available data indicate that the critical effect of chlorine dioxide is neurodevelopmental toxicity.

#### **4.5.1.2. Chlorite**

A number of studies have examined the subchronic/chronic toxicity of chlorite; however, only the Harrington et al. (1995a) study examined a wide range of endpoints. This study identified a NOAEL and LOAEL of 7.4 and 19 mg/kg-day, respectively, for stomach lesions and alterations in spleen and adrenal weights in rats receiving gavage doses of sodium chlorite. The bolus administration of sodium chlorite might have contributed to the stomach lesions; these effects might not have been observed if the sodium chlorite had been administered in the drinking water. Haag (1949) found renal effects in rats drinking 9.3 mg/kg-day chlorite (NOAEL of 0.7 mg/kg-day); interpretation of the results of this study is limited by the small numbers of animals that underwent pathological examination and the limited number of endpoints examined. Abdel-Rahman et al. (1984b) and Couri and Abdel-Rahman (1980) found decreases in osmotic fragility, blood glutathione levels, and blood catalase activity in rats exposed to 1 and 10 mg/kg-day chlorite in drinking water. It is unclear, however, if these effects are statistically or biologically significant. In contrast, Moore et al. (1980) and Moore and Calabrese (1982) found

increases in osmotic fragility in mice exposed to 22 mg/kg-day chlorite in drinking water. Bercz et al. (1982) found decreases in erythrocyte and hemoglobin levels and decreases in T4 levels in monkeys exposed to 58.4 mg/kg-day chlorite.

As with chlorine dioxide, developmental toxicity appears to be the most sensitive effect of oral chlorite exposure. At exposure levels of 3 mg/kg-day and 6 mg/kg-day, Mobley et al. (1990) found significant decreases in exploratory activity in rat pups exposed to chlorite in utero. The changes at 3 mg/kg-day were small, whereas changes observed at 6 mg/kg-day were more consistent with findings from several other studies. Similarly, lowered auditory startle response and reduced liver weight were observed at 6 mg/kg-day, but not at 3 mg/kg-day, in rats in a two-generation study (CMA, 1996). At higher concentrations (19–28 mg/kg-day), decreases in fetal/pup body weight have been observed in mice and rabbits (Moore et al., 1980; Moore and Calabrese, 1982; Harrington et al., 1995b). Data from Carlton and Smith (1985) and Carlton et al. (1987) suggest that sperm may be a sensitive target of toxicity. Reductions in sperm progressive movement and increases in abnormal sperm have been observed in rats exposed to 7.5 mg/kg-day chlorite in drinking water for 72–76 days. However, the CMA (1996) two-generation study did not find any alterations in reproductive performance in rats exposed to 22.7 mg/kg-day chlorite in drinking water.

#### **4.5.2. Inhalation Exposure**

##### **4.5.2.1. Chlorine Dioxide**

Several human studies have examined the toxicity of inhaled chlorine dioxide (Gloemme and Lundgren, 1957; Elkins, 1959; Ferris et al., 1967; Exner-Freisfeld et al., 1986; Kennedy et al., 1991; Meggs et al., 1996). Despite the limitations of these studies (including poor exposure assessment, small number of subjects, and concomitant exposure to chlorine and/or sulfur dioxide), they consistently demonstrate that the respiratory tract is a very sensitive target of toxicity.

A series of studies by Paulet and Desbrousses (1970, 1972, 1974) and Dalhamn (1957) examined the acute and subchronic toxicity of chlorine dioxide in rats and rabbits. As with the human studies, the respiratory tract is the most sensitive target of toxicity. The effects include alveolar congestion and hemorrhage, bronchial inflammation, and peribronchiolar edema. A NOAEL for these effects has not been identified; the lowest LOAEL is 1 ppm (2.8 mg/m<sup>3</sup>) in rats exposed to chlorine dioxide 5 hours/day, 5 days/week for 2 months (Paulet and Desbrousses, 1972).

##### **4.5.2.2. Chlorite**

No data are available on the toxicity of inhaled chlorite.

## **4.6. WEIGHT-OF-EVIDENCE EVALUATION AND CANCER CHARACTERIZATION—SYNTHESIS OF HUMAN, ANIMAL, AND OTHER SUPPORTING EVIDENCE, CONCLUSIONS ABOUT HUMAN CARCINOGENICITY, AND LIKELY MODE OF ACTION**

### **4.6.1. Chlorine Dioxide**

Under the current guidelines (U.S. EPA, 1986a), chlorine dioxide is classified as Group D, not classifiable as to human carcinogenicity because of inadequate data in humans and animals. Under the draft Carcinogen Assessment Guidelines (U.S. EPA, 1996a), the human carcinogenicity of chlorine dioxide cannot be determined because no satisfactory human or animal studies assessing the chronic carcinogenic potential of chlorine dioxide were located.

No human or animal studies assessing the carcinogenic potential of chlorine dioxide were located. The carcinogenic potential of concentrates prepared from drinking water treated with chlorine dioxide was tested by Miller et al. (1986). The concentrates did not increase incidence of lung adenomas in Strain A mice, skin tumor frequency in mice, or incidence of gamma-glutamyl transpeptidase positive foci (a measure of preneoplastic changes) in rat livers. Robinson et al. (1986) found significant increases in skin thickness in SENCAR mice immersed in chlorine dioxide, suggesting that high concentrations of chlorine dioxide are capable of inducing hyperplastic responses in the mouse skin.

Both positive and negative results have been found in genotoxicity studies of chlorine dioxide. Exposure to chlorine dioxide did not induce chromosomal aberrations *in vitro*, but it did increase occurrence of reverse mutations (Ishidate et al., 1984). *In vivo* assays did not find increases in micronucleus induction, chromosomal aberrations, or sperm-head abnormalities following oral exposure (Meier et al., 1985), but they did find increases in micronuclei induction after intraperitoneal injection (Hayashi et al., 1988).

### **4.6.2. Chlorite**

Under the current guidelines (U.S. EPA, 1986a), chlorite is classified as Group D, not classifiable as to human carcinogenicity because of inadequate data in humans and animals. Under the draft Carcinogen Assessment Guidelines (U.S. EPA, 1996a), the human carcinogenicity of chlorite cannot be determined because of a lack of human data and limitations in animal studies.

No human studies assessing the carcinogenic potential of chlorite were located. Chlorite was tested for potential carcinogenicity in rat and mouse drinking water studies (Kurokawa et al., 1986; Yokose et al., 1987). These studies do not provide sufficient evidence to draw conclusions as to the carcinogenic potential of chlorite in humans. In the rat study (Kurokawa et al., 1986), exposure to sodium chlorite did not significantly increase the incidence of tumors. The short exposure duration (85 weeks) and high incidence of Sendai viral infection in control and exposed rats limit the use of this study to assess carcinogenicity.

In the mouse drinking water study (Kurokawa et al., 1986; Yokose et al., 1987), significant increases in liver and lung tumors were observed in male mice. Combined incidence of hepatocellular nodules and hepatocellular carcinomas was increased in the low-dose group, and combined incidence of lung adenomas and adenocarcinomas was elevated in the high-dose group relative to concurrent controls. However, these tumor incidences were within the range of values of historical controls in the study laboratory and in the National Toxicology Program laboratories (Kurokawa et al., 1986). This study is considered inadequate for assessing carcinogenicity because of the relatively short exposure duration (80 weeks) and the high incidence of early mortality in the concurrent control males from excessive fighting, making statistical comparisons between concurrent controls and treated animals difficult to interpret. No increases in tumor incidence were seen in female mice in this study.

Chlorite has been shown to be mutagenic in in vitro assays for reverse mutations and chromosome aberrations (Ishidate et al., 1984) and in an in vivo assay of micronucleus induction in which mice received an intraperitoneal injection of sodium chlorite (Hayashi et al., 1988). In vivo assays for micronucleus induction, chromosome aberrations, and sperm-head abnormalities were negative in mice receiving gavage doses of chlorite for 5 days (Meier et al., 1985; Hayashi et al., 1988).

## **4.7. SUSCEPTIBLE POPULATIONS**

### **4.7.1. Possible Childhood Susceptibility**

#### **4.7.1.1. *Chlorine Dioxide and Chlorite***

Developmental delays have been observed in animal studies following in utero and postnatal exposure to ingested chlorine dioxide or chlorite, suggesting that infants and children may be more likely than adults to experience adverse effects following exposure to these chemicals, although the reasons for this increased sensitivity are not fully understood. It is well recognized that neurological development continues after birth and that gastrointestinal uptake of many nutrients and chemicals is greater in the neonate than the adult.

### **4.7.2. Possible Gender Differences**

#### **4.7.1.2. *Chlorine Dioxide and Chlorite***

No data are available to suggest there are gender differences in the toxicity of chlorine dioxide or chlorite.



## 5. DOSE-RESPONSE ASSESSMENTS

### 5.1. ORAL REFERENCE DOSE (RfD)

#### 5.1.1. Choice of Principal Study and Critical Effect—With Rationale and Justification

In general, human studies have not found adverse effects in individuals consuming low concentrations (0.04–0.15 mg/kg-day) of chlorine dioxide or chlorite in experimental studies (Lubbers et al., 1981, 1982, 1984a) or consuming drinking water disinfected with chlorine dioxide (Michael et al., 1981; Tuthill et al., 1982). An epidemiology study by Kanitz et al. (1996) found increases in the risk of several developmental effects (neonatal jaundice, small cranial circumference, and shorter body length) in a community with chlorine dioxide-disinfected drinking water. However, the Kanitz et al. (1996) study has numerous limitations (including multiple chemical exposures; lack of exposure data; lack of control for smoking, age, and nutritional habits; and atypical control data), making it difficult to interpret the study findings.

In animals, the most sensitive effect following oral exposure to chlorine dioxide or chlorite is neurodevelopmental delay. In utero exposure to chlorine dioxide or postnatal gavage administration of chlorine dioxide has resulted in altered brain development (decreases in brain weight, protein content, and cell number) (Taylor and Pfohl, 1985; Toth et al., 1990) and decreased locomotor or exploratory activity (Orme et al., 1985; Taylor and Pfohl, 1985; Mobley et al., 1990). The LOAEL for these effects is 14 mg/kg-day chlorine dioxide (Orme et al., 1985; Taylor and Pfohl, 1985; Mobley et al., 1990; Toth et al., 1980); Orme et al. (1985) identified a NOAEL of 3 mg/kg-day.

Neurobehavioral effects (lowered auditory startle amplitude, decreased brain weight, and decreased exploratory activity) are also the most sensitive endpoints following oral exposure to chlorite (Mobley et al., 1990; CMA, 1996). The LOAEL identified in the Mobley et al. (1990) developmental toxicity study and the CMA (1996) two-generation developmental toxicity study is 6 mg/kg-day chlorite; Mobley et al. (1990) also found significant decreases in exploratory activity at 3 mg/kg-day, but the difference between activity in this group and the controls was small. Thus, the NOAEL for neurobehavioral effects is 3 mg/kg-day chlorite. At higher concentrations (22–28 mg/kg-day chlorite), decreases in fetal/pup body weight have also been observed in mice and rabbits (Moore and Calabrese, 1982; Moore et al., 1980; Harrington et al., 1995b).

Chlorine dioxide in drinking water rapidly degrades to chlorite; in the Michael et al. (1981) study, chlorine dioxide rapidly disappeared from the stored water (within 2–4 hours) and chlorite levels concomitantly increased. Once absorbed, chlorine dioxide and chlorite are cleared from the blood at similar rates and are similarly distributed throughout the body (Abdel-Rahman et al., 1979b, 1982). Additionally, chloride is the major in vivo degradation product of both chlorine dioxide and chlorite. Available data suggest that chlorine dioxide and chlorite have similar targets of toxicity and potencies. Therefore, the toxicity information for chlorite is relevant to deriving an RfD for chlorine dioxide.

The CMA (1996) two-generation study was selected as the critical study for the development of an RfD for both chlorine dioxide and chlorite. Both in its study report (CMA 1996) and in a later journal article (Gill et al., 2000), CMA reported that the study defined a NOAEL of 70 ppm (6 mg/kg-day chlorite) and a LOAEL of 300 ppm (28.6 mg/kg-day chlorite) based on hematologic toxicity. For the reasons outlined below, EPA disagrees with CMA's choice of NOAEL and LOAEL values. Alterations in multiple endpoints define the LOAEL-NOAEL boundary in the CMA study. Effects observed included statistically significant decreases in pup body weight, absolute brain weight, liver weight, and lowered startle amplitude at the 28.6 mg/kg-day dose. Statistically significant decreases in auditory startle amplitude (F1 and F2 generations) and absolute and relative liver weights (F0 and F1) occurred at 6 mg/kg-day. Although different responses were found for auditory startle (as indicated by measures of amplitude, latency, and habituation), this is not unexpected given that these measures examine different aspects of nervous system function and thus can be differently affected. Transient alterations in neurofunctional (or neurochemical) measures, such as in the auditory startle response, can occur without neuropathological changes and are considered of neurotoxic concern (U.S. EPA, 1998a). Some of effects observed at 6 mg/kg-day and 28.6 mg/kg-day occurred in both sexes and in more than one generation. These effects are considered toxicologically significant, which is consistent with EPA guidelines for reproductive, developmental, and neurotoxicity risk assessment (U.S. EPA, 1991, 1996b, 1998a). The NOAEL for this study is 3 mg/kg-day chlorite and the LOAEL is 6 mg/kg-day chlorite based on lowered auditory startle amplitude and decreased liver weight.

Although the CMA (1996) study is adequate, having been conducted with sufficient numbers of animals of both sexes at multiple dose levels showing a range of effects, and having examined numerous endpoints, there are several limitations. Lack of pair-watered and pair-fed control animals confounds the results and precludes making definitive conclusions as to whether the alterations in food and water consumption and body weight are related to water palatability or a direct toxic effect of the agent. Discontinuation of exposure for the animals undergoing neurotoxicity testing limits the likelihood of finding a positive effect, precludes comparison of the data with those of other rats with continued exposure, and does not reflect the expected lifetime exposure by humans to these chemicals in drinking water. In addition, a lack of detailed description of experimental methods and positive control data (including estimates of variability), and in some cases inappropriate statistical analysis, limits interpretation of the neurobehavioral tests.

The principal study is supported by the developmental studies by Orme et al. (1985), Taylor and Pfohl (1985), Mobley et al. (1990), and Toth et al. (1990), wherein rats administered chlorite or chlorine dioxide at similar dosages in drinking water also showed alterations in exploratory and locomotor behavior and reduced brain weights (NOAELs of 3 mg/kg-day; LOAELs of 14 mg/kg-day).

### **5.1.2. Methods of Analysis—Including Models (PBPK, BMD, etc.)**

The NOAEL/LOAEL approach was used to derive RfDs for chlorine dioxide and chlorite. The RfD was derived using the NOAEL of 3 mg/kg-day identified in the CMA (1996)

study. This dose was determined from the nominal water concentration based on measured water consumption and adjusted for the molecular weight of the salt, so that doses are expressed as the chlorite ion. (For example, males administered 35 ppm had intakes of sodium chlorite equivalent to 3.9 mg/kg-day. Adjusting for the molecular weight of sodium chlorite [MW = 90.5] relative to the chlorite ion [MW = 67.5] gives the NOAEL dose of 3 mg/kg-day chlorite.)

### **5.1.3. RfD Derivation—Including Application of Uncertainty Factors and Modifying Factors**

The RfDs for chlorine dioxide and chlorite were derived by dividing the NOAEL of 3 mg/kg-day by an uncertainty factor of 100. This composite factor includes a factor of 10 to account for uncertainties associated with interspecies extrapolation and a factor of 10 for intrahuman variability. Because the critical effect is a developmental effect in a database that includes chronic studies, it is not necessary to use an uncertainty factor to account for use of a less-than-lifetime study. A default modifying factor of 1 is applied. The resultant RfD is  $3 \times 10^{-2}$  mg/kg-day:

$$\text{RfD} = 3 \text{ mg/kg-day} \div 100 = 3 \times 10^{-2} \text{ mg/kg-day.}$$

## **5.2. INHALATION REFERENCE CONCENTRATION (RfC)**

### **5.2.1. Choice of Principal Study and Critical Effect—With Rationale and Justification**

#### **5.2.1.1. Chlorine Dioxide**

Human studies examining toxicity of inhaled chlorine dioxide are limited to several case reports (Elkins, 1959; Exner-Freisfeld et al., 1986; Meggs et al., 1996) and occupational exposure studies (Gloemme and Lundgren, 1957; Ferris et al., 1967; Kennedy et al., 1991) that involved concurrent exposure to chlorine and possibly sulfur dioxide. Although these studies cannot be used to establish risk assessment values, the results of these studies consistently demonstrate that the respiratory tract is a very sensitive target of chlorine dioxide toxicity.

A series of studies by Paulet and Desbrousses (1970, 1972, 1974) and Dalhamn (1957) examined the acute and subchronic toxicity of chlorine dioxide in rats and rabbits. The earliest Paulet and Desbrousses (1970) study identified a LOAEL of 2.5 ppm chlorine dioxide ( $6.9 \text{ mg/m}^3$ ) for thoracic effects (alveolar congestion and hemorrhage; bronchial inflammation) in rats exposed 7 hours/day (presumably 5 days/week) for 30 days and pulmonary effects (alveolar hemorrhage and capillary congestion) in rabbits exposed 4 hours/day (presumably 5 days/week) for 45 days; a NOAEL was not identified. A follow-up study by this group attempted to identify a threshold for respiratory effects (Paulet and Desbrousses, 1972). This study identified a LOAEL of 1 ppm ( $2.8 \text{ mg/m}^3$ ) for pulmonary effects (vascular congestion and peribronchiolar edema) in rats exposed 5 hours/day, 5 days/week for 2 months; a NOAEL was not identified. The Dalhamn (1957) study identified a NOAEL of 0.1 ppm chlorine dioxide ( $0.28 \text{ mg/m}^3$ ) for lung damage in rats exposed 5 hours/day (frequency of weekly exposure not reported) for 10

weeks; a LOAEL of 10 ppm (28 mg/m<sup>3</sup>) for respiratory tract irritation was identified in rats exposed 4 hours/day for 9 days in a 13-day period.

Collectively, the results of the human and animal studies suggest that the respiratory tract is the critical target. The Paulet and Desbrousses (1970, 1972) studies were selected as cocritical studies. The 1972 study identified the lowest LOAEL for a sensitive endpoint (respiratory tract effects); however, the study duration (2 months) is shorter than the typical subchronic study (approximately 90 days) and only one exposure concentration was tested. The 1970 study is used to support the identification of the critical effect and critical concentrations; this study tested several concentrations in two species for durations of 30 or 45 days.

#### **5.2.1.2. Chlorite**

An RfC for chlorite is not recommended at this time. No human or animal studies examining the toxicity of inhaled chlorite were located. Although the available human and animal data on inhaled chlorine dioxide support the derivation of an RfC for this chemical, these data cannot be used to derive an RfC for chlorite. Under ambient conditions, airborne chlorite is likely to exist as a particulate, whereas inhalation exposure to chlorine dioxide is as a gas. Based on their physical and chemical properties, it is anticipated that inhaled chlorine dioxide and chlorite would have very different modes of exposure. Therefore, the potential hazards associated with exposure to these two chemicals are also very different. In the absence of data demonstrating parallels in pharmacokinetic behavior following inhalation exposure—as are available following oral exposure—derivation of an RfC for chlorite from the available data for chlorine dioxide is not recommended.

### **5.2.2. Methods of Analysis—NOAEL/LOAEL**

#### **5.2.2.1. Chlorine Dioxide**

The NOAEL/LOAEL approach was used to calculate the RfC for chlorine dioxide. A benchmark concentration (BMC) analysis could not be conducted because the report of the Paulet and Desbrousses (1970, 1972) studies did not include incidence data.

The RfC was derived using the Paulet and Desbrousses (1970, 1972) studies as co-critical studies. From the LOAEL of 1 ppm for pulmonary effects in rats identified in the Paulet and Desbrousses (1972) study, concentration in mg/m<sup>3</sup> was calculated using a molecular weight of 67.46 and the assumption of 25°C and 760 mmHg:

$$\text{LOAEL} = 1 \text{ ppm} \times 67.46/24.45 = 2.8 \text{ mg/m}^3 \text{ (Paulet and Desbrousses, 1972 - rats).}$$

The duration-adjusted LOAEL (LOAEL<sub>ADJ</sub>) was calculated by multiplying the LOAEL by the daily exposure duration (5 hours/day) and the weekly exposure frequency (5 days/week):

$$\text{LOAEL}_{\text{ADJ}} = 2.8 \text{ mg/m}^3 \times 5 \text{ hours/24 hours} \times 5 \text{ days/7 days} = 0.41 \text{ mg/m}^3 \text{ (rat).}$$

The human equivalent concentration (HEC) for the LOAEL (LOAEL<sub>HEC</sub>) was calculated by multiplying the LOAEL<sub>ADJ</sub> by the regional gas dose ratio for the thoracic region of the respiratory tract (RGDR<sub>TH</sub>). The RGDR<sub>TH</sub> was calculated using the following equation:

$$RGDR_{TH} = \frac{\left[ \frac{MV}{SA} \right]_A}{\left[ \frac{MV}{SA} \right]_H}$$

where MV is the minute volume in rats (0.118 m<sup>3</sup>/min; 0.17 m<sup>3</sup>/day) and humans (13.8 m<sup>3</sup>/min; 20 m<sup>3</sup>/day) and SA is the surface area of the thoracic region in rats (3461.6 cm<sup>2</sup>) and humans (640,581 cm<sup>2</sup>).

$$LOAEL_{HEC} = 0.41 \text{ mg/m}^3 \times [(0.118 \text{ m}^3/\text{min} / 3461.6 \text{ cm}^2) / (13.8 \text{ m}^3/\text{min} / 640,581 \text{ cm}^2)];$$

$$LOAEL_{HEC} = 0.41 \text{ mg/m}^3 \times 1.57 = 0.64 \text{ mg/m}^3.$$

Similarly, for the Paulet and Desbrousses (1970) study, using values of 1.10 m<sup>3</sup>/min for the minute volume and 59,100 cm<sup>2</sup> for the surface area of the thoracic region of rabbits, the calculation of the LOAEL<sub>HEC</sub> is as follows:

$$LOAEL = 2.5 \text{ ppm} \times 67.46/24.45 = 6.9 \text{ mg/m}^3.$$

$$LOAEL_{ADJ} = 6.9 \text{ mg/m}^3 \times 4 \text{ hours}/24 \text{ hours} \times 5 \text{ days}/7 \text{ days} = 0.82 \text{ mg/m}^3.$$

$$LOAEL_{HEC} = 0.82 \text{ mg/m}^3 \times [(1.10 \text{ m}^3/\text{min} / 59,100 \text{ cm}^2) / (13.8 \text{ m}^3/\text{min} / 640,581 \text{ cm}^2)];$$

$$LOAEL_{HEC} = 0.82 \text{ mg/m}^3 \times 0.596 = 0.49 \text{ mg/m}^3.$$

### 5.2.3. RfC Derivation—Including Application of Uncertainty Factors and Modifying Factors

#### 5.2.3.1. Chlorine Dioxide

The RfC for chlorine dioxide is derived by dividing the LOAEL<sub>HEC</sub> thoracic effects by an uncertainty factor of 3,000. This uncertainty factor comprises a factor of 10 to account for extrapolation of a chronic RfC from a subchronic study, 3 for interspecies extrapolation using dosimetric adjustments, 10 for intrahuman variability, and 10 to account for extrapolation from a LOAEL for mild effects and for the lack of inhalation developmental and reproductive toxicity studies. EPA's policy is to limit the size of the composite uncertainty factor to 3,000 in recognition of the lack of independence of these factors (U.S. EPA, 1994b). The LOAEL to NOAEL and database uncertainties are therefore coalesced into one uncertainty factor of 10. The composite uncertainty factor for this RfC is therefore 3,000. No modifying factor is used for this assessment.

$$\text{RfC} = 0.64 \text{ mg/m}^3 \div 3,000 = 2 \times 10^{-4} \text{ mg/m}^3.$$

or

$$\text{RfC} = 0.49 \text{ mg/m}^3 \div 3,000 = 2 \times 10^{-4} \text{ mg/m}^3.$$

As can be seen, the same value for the RfC can be calculated using the LOAEL from either of the key studies. Note that this is the same value as was verified by the RfC workgroup in 1990, as no new data were available.

### **5.3. CANCER ASSESSMENT**

#### **5.3.1. Chlorine Dioxide**

The oral and inhalation databases are inadequate to assess the carcinogenicity of chlorine dioxide in humans or animals; thus, derivation of an oral slope factor and inhalation unit risk level is precluded.

#### **5.3.2. Chlorite**

The oral and inhalation databases are inadequate to assess the carcinogenicity of chlorite in humans or animals; thus, derivation of an oral slope factor and inhalation unit risk level is precluded.

## **6. MAJOR CONCLUSIONS IN THE CHARACTERIZATION OF HAZARD AND DOSE RESPONSE**

### **6.1. HUMAN HAZARD POTENTIAL**

Chlorine dioxide and chlorite are strong oxidizing agents used as drinking water disinfectants and to bleach textile and wood pulp for paper manufacturing. Chlorine dioxide and chlorite are rapidly absorbed from the gastrointestinal tract and slowly cleared from the blood. Chlorine dioxide and chlorite, primarily in the form of chloride, are widely distributed throughout the body and predominantly excreted in the urine. Chloride is the major urinary “metabolite” for both chlorine dioxide and chlorite. No data are available on the pharmacokinetics of inhaled or dermally applied chlorine dioxide or chlorite.

In general, human ingestion studies have found no adverse effects in adults and neonates living in areas with chlorine dioxide-disinfected water. However, these studies are fraught with methodological problems, such as lack of characterization of exposure to other agents in the drinking water and control of potential confounding factors. These studies do little to confirm a possible association between exposure to chlorine dioxide and chlorite and adverse reproductive or developmental outcome in humans. Inhalation exposure to chlorine dioxide results in

respiratory irritation in humans. However, these studies also poorly characterize exposure, and the occupational exposure studies involve concomitant exposure to chlorine and/or sulfur dioxide.

Animal toxicity databases for chlorine dioxide and chlorite is fairly comprehensive, composed of subchronic and chronic studies, reproductive and developmental studies, and toxicokinetic and mechanistic information. Multiple animal studies have shown similar alterations in neurodevelopmental endpoints, such as brain weight and behavioral measures. The majority of these studies have used sufficient numbers of animals and employed routes of exposure (gavage and drinking water) relevant to human exposure. The majority of the developmental studies have utilized rats and have shown a fairly consistent definition of the NOAEL/LOAEL.

Reproductive studies in male animals are not consistent in demonstrating alterations in spermatogenic indices, that is, abnormal morphology or motility; however, reported effects seem to appear at doses higher than the adverse developmental effects. Similarly, clinically or toxicologically significant alterations in hematologic parameters occur at higher doses.

The mode of action for induction of adverse neurodevelopmental effects is not known. It is also not known whether the rat is an adequate model for toxicity of chlorine dioxide and chlorite in humans. However, this species is widely used to characterize reproductive and developmental effects in humans.

Animal studies have demonstrated that the respiratory tract is the most sensitive target of toxicity following inhalation exposure to chlorine dioxide. No animal inhalation studies are available for chlorite.

No human studies assessing the carcinogenic potential of chlorine dioxide or chlorite were located. Chlorine dioxide carcinogenicity has not been tested in animal bioassays. Chlorite was not shown to increase tumor incidences in rats and mice; these studies are considered inadequate for assessing human carcinogenicity because the exposure was for less than a lifetime, a high incidence of Sendai virus was found in the rats, and mortality was high in the mouse control group because of excessive fighting.

Areas of scientific uncertainty in this assessment include the mode of action of chlorine dioxide and chlorite in producing adverse effects on multiple organ systems, including reproductive, developmental, and hematologic effects. Inherent in the uncertainty over the mode of action is identification of the susceptible populations or subgroups, and additional research in this area would help to better quantify the additional risk to these groups. Well-designed and conducted epidemiologic studies in communities with drinking water disinfected with these chemicals would decrease uncertainty in the utilization of animal models for determination of human health effects.

## 6.2. DOSE RESPONSE

Quantitative estimates of human risk as a result of low-level chronic chlorine dioxide or chlorite oral exposure are based on animal experiments, because no adequate human exposure data are available. Neurodevelopmental toxicity is the primary effect in offspring of rats exposed to chlorine dioxide or chlorite in drinking water. Quantitative estimates of human risk as a result of low-level chronic chlorine dioxide inhalation exposure are based on animal experiments, because no adequate human inhalation data are available. The respiratory tract appears to be the primary target of toxicity in human and animal studies.

The oral RfD for chlorine dioxide or chlorite is  $3 \times 10^{-2}$  mg/kg-day. This is 1/100 of the NOAEL, using neurodevelopmental toxicity in a two-generation rat study as the indicator of adverse effects. Overall confidence in this RfD assessment is medium to high. Confidence in the CMA (1996) principal study is medium. Although the study design and analytical approaches are consistent with EPA testing guidelines, some limitations in the design and conduct of the study exist. Confidence in the database is high because there are studies in multiple species, chronic duration studies in males and females, reproductive/developmental toxicity studies, and a multigenerational study. The threshold for adverse effects is consistently defined among the animal studies.

The inhalation RfC for chlorine dioxide is  $2 \times 10^{-4}$  mg/m<sup>3</sup>. This concentration is 1/3,000 of the HEC for thoracic effects in rats (Paulet and Desbrousses, 1970, 1972). No human or animal data were located for chlorite that could be used to derive an RfC. Overall confidence in the RfC for chlorine dioxide is low. The studies by Paulet and Desbrousses (1970, 1972) identify only a LOAEL in rats and rabbits for adverse lung effects in 60- and 45-day studies and lack experimental detail. There were no adequate subchronic or chronic inhalation studies that examined extrapulmonary effects, and no acceptable developmental or reproductive studies on inhaled chlorine dioxide.

## 7. REFERENCES

Abdel-Rahman, MS; Couri, D; Bull, RJ. (1979a) Kinetics of ClO<sub>2</sub> and effects of ClO<sub>2</sub>, ClO<sub>2</sub><sup>-</sup>, and ClO<sub>3</sub> in drinking water on blood glutathione and hemolysis in rat and chicken. *J Environ Pathol Toxicol* 3:431-449.

Abdel-Rahman, MS; Couri, D; Jones, JD. (1979b) Chlorine dioxide metabolism in rat. *J Environ Pathol Toxicol* 3:421-430.

Abdel-Rahman, MS; Couri, D; Bull, RJ. (1982) Metabolism and pharmacokinetics of alternate drinking water disinfectants. *Environ Health Perspect* 46:19-23.



Abdel-Rahman, MS; Couri, D; Bull, RJ. (1984a) The kinetics of chlorite and chlorate in the rat. *J Am Coll Toxicol* 3:261-267.

Abdel-Rahman, MS; Couri, D; Bull, RJ. (1984b) Toxicity of chlorine dioxide in drinking water. *J Am Coll Toxicol* 3:277-284.

Bercz, JP; Jones, LL; Garner, L; et al. (1982) Subchronic toxicity of chlorine dioxide and related compounds in drinking water in the nonhuman primate. *Environ Health Perspect* 46:47-55.

Bercz, JP; Jones, LL; Harrington, RM; et al. (1986) Mechanistic aspects of ingested chlorine dioxide on thyroid function: impact of oxidants on iodide metabolism. *Environ Health Perspect* 69:249-255.

Bianchine, JR; Lubbers, JR; Chauhan, S; et al. (1981) Study of chlorine dioxide and its metabolites in man. Final report on EPA Grant No. 805643. EPA-600/1-82-068. Available from: National Technical Information Service, Springfield, Virginia; PB82-109356.

Budavari, S; O'Neil, MJ; Smith, A; et al. (eds). (1989) *The Merck index: an encyclopedia of chemicals, drugs, and biologicals*, 11th ed. Whitehouse Station, NJ: Merck and Co, Inc.

Carlton, BD; Smith, MK. (1985) Reproductive effects of alternate disinfectants and their by-products. In: Jolley, RL, et al., eds. *Water chlorination: environmental impact and health effects*, vol. 5. Chelsea, MI: Lewis Publications, pp. 295-305.

Carlton, BD; Habash, DL; Barsaran, AH; et al. (1987) Sodium chlorite administration in Long-Evans rats: reproductive and endocrine effects. *Environ Res* 42:238-245.

Carlton, BD; Basaran, AH; Mezza, LE; et al. (1991) Reproductive effects in Long-Evans rats exposed to chlorine dioxide. *Environ Res* 56:170-177.

Chemical Manufacturers Association. (CMA) (1996) Sodium chlorite: drinking water rat two-generation reproductive toxicity study. Quintiles Report Ref. CMA/17/96.

Couri, D; Abdel-Rahman, MS. (1980) Effect of chlorine dioxide and metabolites on glutathione dependent system in rat, mouse and chicken blood. *J Environ Pathol Toxicol* 3:451-460.

Couri, D; Miller, CH; Bull, RJ; et al. (1982) Assessment of maternal toxicity, embryotoxicity and teratogenic potential of sodium chlorite in Sprague-Dawley rats. *Environ Health Perspect* 46:25-29.

Dalhamn, T. (1957) Chlorine dioxide: toxicity in animal experiments and industrial risks. *Arch Ind Health* 15:101-107.

Daniel, FB; Condie, LW; Robinson, M; et al. (1990) Comparative subchronic toxicity studies of three disinfectants. *J Am Water Works Assoc* 82:61-69.

Elkins, HB. (1959) The chemistry of industrial toxicology, 2nd ed. New York: Wiley and Sons, pp. 89-90.

Exner-Freisfeld, H; Kronenberger, H; Meier-Sydow, J; et al. (1986) Intoxication from bleaching with sodium chlorite. The toxicology and clinical course [German with English abstract]. Dtsch Med Wochenschr 111(50):1927-1930.

Ferris, BG, Jr; Burgess, WA; Worcester, J. (1967) Prevalence of chronic respiratory disease in a pulp mill and a paper mill in the United States. Br J Ind Med 24(1):26-37.

Gill, MW, Swanson, MS; Murphy, SR, et al. (2000) Two-generation reproduction and developmental neurotoxicity study with sodium chlorite in the rat. J Appl Toxicol 20:291-303.

Gloemme, J; Lundgren, KD. (1957) Health hazards from chlorine dioxide. Arch Ind Health 16:169-176.

Haag, HB. (1949) The effect on rats of chronic administration of sodium chlorite and chlorine dioxide in the drinking water. Report to the Mathieson Alkali Works from H.B. Haag of the Medical College of Virginia. February 7, 1949.

Harrington, RM; Shertzer, HG; Bercz, JP. (1986) Effects of chlorine dioxide on thyroid function in the African green monkey and the rat. J Toxicol Environ Health 19:235-242.

Harrington, RM; Romano, RR; Gates, D; et al. (1995a) Subchronic toxicity of sodium chlorite in the rat. J Am Coll Toxicol 14:21-33.

Harrington, RM; Romano, RR; Irvine, L. (1995b) Developmental toxicity of sodium chlorite in the rabbit. J Am Coll Toxicol 14:109-118.

Hayashi, M; Kishi, M; Sofuni, T; et al. (1988) Micronucleus test in mice on 39 food additives and eight miscellaneous chemicals. Food Chem Toxicol 26:487-500.

Ishidate, M; Sofuni, T; Yoshikawa, K; et al. (1984) Primary mutagenicity screening of food additives currently used in Japan. Food Chem Toxicol 22:623-636.

Kanitz, S; Franco, Y; Patrone, V; et al. (1996) Associations between drinking water disinfection and somatic parameters at birth. Environ Health Perspect 104:516-520.

Kennedy, SM; Enarson, DA; Janssen, RG; Chan-Yeung, M. (1991) Lung health consequences of reported accidental chlorine gas exposures among pulp mill workers. Am Rev Respir Dis 143:74-79.

Kurokawa, Y; Takamura, N; et al. (1984) Studies on the promoting and complete carcinogenic activities of some oxidizing chemicals in skin carcinogenesis. Cancer Lett 24:299-304.

Kurokawa, Y; Takamura, S; Konishi, Y; et al. (1986) Long-term in vivo carcinogenicity tests of potassium bromate, sodium hypochlorite, and sodium chlorite conducted in Japan. *Environ Health Perspect* 69:221-235.

Lubbers, JR; Chauhan, S; Bianchine, JR. (1981) Controlled clinical evaluations of chlorine dioxide, chlorite and chlorate in man. *Fundam Appl Toxicol* 1:334-338.

Lubbers, JR; Chauhan, S; Bianchine, JR. (1982) Controlled clinical evaluations of chlorine dioxide, chlorite and chlorate in man. *Environ Health Perspect* 46:57-62.

Lubbers, JR; Chauhan, S; Miller, JK; et al. (1984a) The effects of chronic administration of chlorine dioxide, chlorite and chlorate to normal healthy adult male volunteers. *J Environ Pathol Toxicol Oncol* 5:229-238.

Lubbers, JR; Chauhan, S; Miller, JK; et al. (1984b) The effects of chronic administration of chlorite to glucose-6-phosphate dehydrogenase deficient healthy adult male volunteers. *J Environ Pathol Toxicol Oncol* 5:239-242.

Meggs, WJ; Elsheik, T; Metzger, WJ; et al. (1996) Nasal pathology and ultrastructure in patients with chronic airway inflammation (RADS and RUDS) following an irritant exposure. *Clin Toxicol* 34:383-396.

Meier, JR; Bull, RJ; Stober, JA; et al. (1985) Evaluation of chemicals used for drinking water disinfection for production of chromosomal damage and sperm-head abnormalities in mice. *Environ Mutagen* 7:201-211.

Michael, GE; Miday, RK; Bercz, JP; et al. (1981) Chlorine dioxide water disinfection: a prospective epidemiology study. *Arch Environ Health* 36:20-27.

Miller, RG; Kopler, FC; Condie, LW; et al. (1986) Results of toxicological testing of Jefferson Parish pilot plant samples. *Environ Health Perspect* 69:129-139.

Mobley, SA; Taylor, DH; Laurie, RD; et al. (1990) Chlorine dioxide depresses T3 uptake and delays development of locomotor activity in young rats. In: Jolley, RL, et al., eds. *Water chlorination: chemistry, environmental impact and health effects*, vol. 6. Chelsea, MI: Lewis Publications, pp. 347-358.

Moore, GS; Calabrese, EJ. (1982) Toxicological effects of chlorite in the mouse. *Environ Health Perspect* 46:31-37.

Moore, GS; Calabrese, EJ; Leonard, DA. (1980) Effects of chlorite exposure on conception rate and litters of A/J strain mice. *Bull Environ Contam Toxicol* 25:689-696.

Orme, J; Taylor, DH; Laurie, RD; et al. (1985) Effects of chlorine dioxide on thyroid function in neonatal rats. *J Toxicol Environ Health* 15:315-322.

Paulet, G; Desbrousses, S. (1970) On the action of ClO<sub>2</sub> at low concentrations on laboratory animals. Arch Mal Prof 31(3):97-106.

Paulet, G; Desbrousses, S. (1972) On the toxicology of chlorine dioxide. Arch Mal Prof 33(1-2):59-61.

Paulet, G; Desbrousses, S. (1974) Action of a discontinuous exposure to chlorine dioxide (ClO<sub>2</sub>) on the rat [French with English translation.]. Arch Mal Prof 35:797-804.

Robinson, M; Bull, RJ; Schmaer, M; Long, RF. (1986) Epidermal hyperplasia in the mouse skin following treatment with alternate drinking water disinfectants. Environ Health Perspect 69:293-300.

Scatina, J; Abdel-Rahman, MS; Gerges, SE; et al. (1984) Pharmacodynamics of Alcide, a new antimicrobial compound, in rat and rabbit. Fundam Appl Toxicol 4:479-484.

Selevan, S. (1997) Comments on Italian study: association between drinking water disinfection and somatic parameters by Kanitz et al., Environ Health Perspect 104(5):516-520, 1996. Memorandum to J. Wiltse, U.S. EPA, Washington, DC, May 7.

Suh, DH; Abdel-Rahman, MS; Bull, RJ. (1983) Effect of chlorine dioxide and its metabolites in drinking water on fetal development in rats. J Appl Toxicol 3:75-79.

Taylor, DH; Pfohl, RJ. (1985) Effects of chlorine dioxide on the neurobehavioral development of rats. In: Jolley, RL, et al., eds. Water chlorination: chemistry, environmental impact and health effects, vol. 6. Chelsea, MI: Lewis Publications, pp. 355-364.

Toth, GP; Long, RE; Mills, TS; et al. (1990) Effects of chlorine dioxide on the developing rat brain. J Toxicol Environ Health 31:29-44.

Tuthill, RW; Giusti, RA; Moore, GS; et al. (1982) Health effects among newborns after prenatal exposure to ClO<sub>2</sub>-disinfected drinking water. Environ Health Perspect 46:39-45.

U.S. Environmental Protection Agency. (1986a) Guidelines for carcinogen risk assessment. Federal Register 51(185):33992-34003.

U.S. Environmental Protection Agency. (1986b) Guidelines for the health risk assessment of chemical mixtures. Federal Register 51(185):34014-34025.

U.S. Environmental Protection Agency. (1986c) Guidelines for mutagenicity risk assessment. Federal Register 51(185):34006-34012.

U.S. Environmental Protection Agency. (1988) Recommendations for and documentation of biological values for use in risk assessment. Prepared by Environmental Criteria and Assessment

Office, Office of Health and Environmental Assessment, Cincinnati, OH. EPA 600/6-87/008. Available from: National Technical Information Service, Springfield, VA, PB88-179874/AS.

U.S. Environmental Protection Agency. (1991) Guidelines for developmental toxicity risk assessment. Federal Register 56(234):63798-63826.

U.S. Environmental Protection Agency. (1994a) Interim policy for particle size and limit concentration issues in inhalation toxicity: notice of availability. Federal Register 59(206):53799.

U.S. Environmental Protection Agency. (1994b) Methods for derivation of inhalation reference concentrations and application of inhalation dosimetry. Prepared by Environmental Criteria and Assessment Office, Office of Health and Environmental Assessment, Research Triangle Park, NC. EPA/600/8-90/066F.

U.S. Environmental Protection Agency. (1994c) Peer review and peer involvement at the U.S. Environmental Protection Agency. Signed by the U.S. EPA Administrator, Carol M. Browner, dated June 7, 1994.

U.S. Environmental Protection Agency. (1994d) Final draft of the drinking water criteria document on chlorine dioxide, chlorite, and chlorate. Office of Science and Technology, Office of Water, Washington, DC. Office of Research and Development, Washington, DC.

U.S. Environmental Protection Agency. (1995) Use of the benchmark dose approach in health risk assessment. EPA/630/R-94/007.

U.S. Environmental Protection Agency. (1996a) Proposed guidelines for carcinogen risk assessment. Federal Register 61(79):17960-18011. <http://www.epa.gov/nceawww1/cancer.htm>

U.S. Environmental Protection Agency. (1996b) Reproductive toxicity risk assessment guidelines. Federal Register 61(212):56274-56322. <http://www.epa.gov/ORD/WebPubs/repro/>

U.S. Environmental Protection Agency. (1998a) Guidelines for neurotoxicity risk assessment. Federal Register 63(93):26926-26954. <http://www.epa.gov/nceawww1/nurotox.htm>

U.S. Environmental Protection Agency. (1998b) Science policy council handbook: peer review. Prepared by the Office of Science Policy, Office of Research and Development, Washington, DC. EPA 100-B-98-001.

World Health Organization, Regional Office for Europe. (2000) Health for All Statistical Database. Online. European Public Health Information Network for Eastern Europe. <http://www.euphin.dk/hfa/Phfa.asp>

Yokose, Y; Uchida, K; Nakae, D; et al. (1987) Studies of carcinogenicity of sodium chlorite in B6C3F1 mice. Environ Health Perspect 76:205-210.

## APPENDIX A. EXTERNAL PEER REVIEW— SUMMARY OF COMMENTS AND DISPOSITION

The support document and IRIS summary for chlorine dioxide and chlorite have undergone both internal peer review performed by scientists within EPA and a more formal external review performed by scientists in accordance with EPA guidance on peer review (U.S. EPA, 1994c). Comments made by the internal reviewers were addressed prior to submitting the documents for external peer review and are not part of this appendix. The external peer reviewers were tasked with providing written answers to general questions on the overall assessment and on chemical-specific questions in areas of scientific controversy or uncertainty. A summary of significant comments made by the external reviewers and EPA's response to these comments follows.

**Question 1.** Are you aware of any other data/studies that are relevant (i.e., useful for hazard identification or dose-response assessment) for the assessment of the adverse health effects, both cancer and noncancer, of this chemical?

**Comments:** Two reviewers did not find any new relevant studies that would have any impact on the conclusions of this document. Four additional references were mentioned by the two other reviewers. One reviewer concurred that the results of the EPA evaluation agree with IARC (vol. 52, 1991), and there is inadequate evidence for the carcinogenicity of sodium chlorite in experimental animals. One reviewer commented on sensitive subgroups of the population and potential effects on blood chemistry parameters in renal dialysis patients when chlorine dioxide was used as a disinfectant. Also, one reviewer suggested a statement should be made on whether chlorite can be designated as a tumor promoter based on an initiation/promotion study on mouse skin (Kurokawa et al., 1984) and if the promoting activity is related to epidermal hyperplasia induction after topical exposure to sodium chlorite.

**Response to Comments:** The effects of chlorine dioxide and chlorite on human subjects and blood chemistry are described in the *Drinking Water Criteria Document on Chlorine Dioxide, Chlorite, and Chlorate* (U.S. EPA, 1994d) and in this Toxicological Review. All relevant ingestion studies, including the additional studies mentioned by the reviewers, have been evaluated in the drinking water criteria document, which was used in preparing this Toxicological Review. Changes seen in the tumor promoter study on mouse skin were not statistically significant.

**Question 2.** For RfD, RfC, and cancer, where applicable, have the most appropriate critical effects been chosen? For the cancer assessment, are the tumors observed biologically significant?

**Comments:** Two reviewers reiterated that it would appear that NOAELs around 3 mg/kg-day for the neurodevelopmental and behavioral effects are the most appropriate to develop the RfD for the oral exposure route, that the selection of the Paulet and Desbrousses (1972) study

for developing the RfC for chlorine dioxide is appropriate, and also that there is still no adequate evidence for the carcinogenicity of chlorine dioxide or chlorite. Other reviewers also stated that there are inadequate cancer data for risk assessment. One reviewer commented that an independent pathology group should review the histopathology diagnoses in the CMA (1996) study.

**Response to Comments:** The CMA (1996) study was vigorously subjected to independent peer review at EPA and by external reviewers. It was also reviewed by the stakeholders. Additional review of the histopathology diagnoses was not performed because the most sensitive endpoints (neurofunctional effects) were not histologic in nature.

**Question 3.** For RfD and RfC and cancer, have the appropriate studies been chosen as principal?

**Comments:** The external reviewers reiterated that appropriate studies were chosen for chlorine dioxide and chlorite. One reviewer stated that actual study reports cited were not available for review; the reviewer also suggested review of additional studies for irritating effects of chlorine dioxide in humans and questioned whether humans were more sensitive than rodents to chlorine dioxide.

**Response to Comments:** EPA cited the suggested studies as appropriate within the text. Studies describing irritating effects of chlorine dioxide in humans are described in the text. Data on the comparative sensitivity of rodents and humans to chlorine dioxide are not available. The 10-fold uncertainty factor for animal to human extrapolation was deemed an appropriate adjustment for this data gap.

**Question 4.** Studies included in the RfD and RfC and cancer under the heading “Supporting/Additional Studies” are meant to lend scientific justification for the designation of critical effect by including any relevant pathogenesis in humans, any applicable mechanistic information, any evidence corroborative of the critical effects, or to establish the comprehensiveness of the data base with respect to various endpoints. Should some studies be removed?

**Comments:** Reviewers indicated that additional and supporting studies cited for the RfD, RfC, and cancer assessments are appropriate and that no studies should be removed. One reviewer commented that he would question the quality and utility of studies that were conducted 50 years ago when quality assurance procedures and chemical production procedures and specifications were not what they are today. One reviewer asked whether any attempts were made to obtain histopathology slides from the unpublished Haag et al. (1949) studies.

**Response to Comments:** EPA agrees that no additional and supporting studies should be removed from this document. EPA did not attempt to acquire the histopathology slides from the unpublished Haag et al. (1949) chronic studies of chlorine dioxide in rats since they are older studies.

**Question 5.** Are there other data that should be considered in developing the uncertainty factors or the modifying factor? Do you consider that the data support use of different (default) values than those proposed?

**Comments:** One reviewer was unaware of any additional or other data that should be considered in developing the uncertainty factors for chlorine dioxide or chlorite. One reviewer questioned whether it would be useful to review/discuss the risk analysis that supports the use of chlorine dioxide and sodium chlorite as indirect food additives or as components of consumer products such as mouthwash or toothpaste. A comment was made that the report should compare lifetime animal and human oral exposures to chlorine dioxide or chlorite on the basis of mg/kg body weight and mg/mL body surface. One reviewer commented that patients on extracorporeal hemodialysis using home equipment may be potentially exposed to 70–90 times the residues exposed by adults who merely consume the water. A question was raised on the data available to support selection of an uncertainty factor that takes into account for those individuals with deficient glucose-6-phosphate dehydrogenase activity and neonates with sluggish methemoglobin reductase activity.

**Response to Comments:** EPA agrees with a reviewer that additional or other data are not warranted for this risk assessment. EPA followed the customary guideline for risk assessment for development of an RfD derivation. EPA did not examine chlorine dioxide or chlorite as indirect food additives or as components of consumer products such as mouthwash or toothpaste. EPA discussed individuals with deficiency in glucose-6-phosphate dehydrogenase and methemoglobin reductase as a potential susceptible subpopulation in the drinking water criteria document (U.S. EPA, 1994d). EPA thinks that an uncertainty factor of 100 is adequate to protect this group as well as the 80,000 Americans on renal dialysis.

**Question 6.** Do the confidence statements and weight-of-evidence statements present a clear rationale and accurately reflect the utility of the principal study and the comprehensiveness of the data? Do these statements make sufficiently apparent all the underlying assumptions and limitations of these assessments? If not, what needs to be added?

**Comments:** External reviewers indicated that the confidence and weight-of-evidence statements were clearly and rationally presented. One reviewer indicated that the comprehensiveness of the data was adequately presented and the underlying assumptions and limitations of the assessments were sufficiently presented. One reviewer mentioned that the confidence statements for the RfC for chlorine dioxide should indicate whether humans are more susceptible to chlorine dioxide.

**Response to Comments:** Adequate information is not available to determine if humans are more susceptible. EPA has applied a 10-fold uncertainty factor for extrapolation from animals to humans to address this area of uncertainty.

**Question 7.** Is the weight of evidence for cancer assigned at the appropriate level (where applicable)?



**Comments:** External reviewers indicated that cancer assessment was not applicable for chlorine dioxide and chlorite, as the data are inadequate. One reviewer commented that a statement should be made concerning the designation of sodium chlorite as a tumor promoter in mouse skin under the conditions examined in the Kurokawa et al. (1984) study.

**Response to Comments:** The reviewers agreed that the cancer assessment was assigned at the appropriate level. EPA does not agree that such a statement should be made as the increased tumor incidence did not attain statistical significance.

# Controlled Clinical Evaluations of Chlorine Dioxide, Chlorite and Chlorate in Man

by Judith R. Lubbers,\* Sudha Chauhan,\* and Joseph R. Bianchine\*

To assess the relative safety of chronically administered chlorine water disinfectants in man, a controlled study was undertaken. The clinical evaluation was conducted in the three phases common to investigational drug studies. Phase I, a rising dose tolerance investigation, examined the acute effects of progressively increasing single doses of chlorine disinfectants to normal healthy adult male volunteers. Phase II considered the impact on normal subjects of daily ingestion of the disinfectants at a concentration of 5 mg/l. for twelve consecutive weeks. Persons with a low level of glucose-6-phosphate dehydrogenase may be expected to be especially susceptible to oxidative stress; therefore, in Phase III, chlorite at a concentration of 5 mg/l. was administered daily for twelve consecutive weeks to a small group of potentially at-risk glucose-6-phosphate dehydrogenase-deficient subjects. Physiological impact was assessed by evaluation of a battery of qualitative and quantitative tests. The three phases of this controlled double-blind clinical evaluation of chlorine dioxide and its potential metabolites in human male volunteer subjects were completed uneventfully. There were no obvious undesirable clinical sequelae noted by any of the participating subjects or by the observing medical team. In several cases, statistically significant trends in certain biochemical or physiological parameters were associated with treatment; however, none of these trends was judged to have physiological consequence. One cannot rule out the possibility that, over a longer treatment period, these trends might indeed achieve proportions of clinical importance. However, by the absence of detrimental physiological responses within the limits of the study, the relative safety of oral ingestion of chlorine dioxide and its metabolites, chlorite and chlorate, was demonstrated.

## Introduction

Chlorine dioxide is currently under serious consideration in the United States as an alternative to chlorine water treatment. Before chlorine dioxide may be used routinely as a water disinfectant, the safety of oral human ingestion of chlorine dioxide and its by-products must be assessed. For this purpose, a controlled clinical evaluation of chlorine dioxide, chlorite and chlorate was undertaken under the auspices of USEPA HERL #CR805643.

The study was conducted in three parts. Phase I was designed to evaluate the acute physiological

effects of progressively increasing doses of disinfectants administered to normal healthy adult males. Chronic ingestion by normal male volunteers was studied in Phase II. Phase III assessed the physiological response of a small group of potentially susceptible individuals, those deficient in glucose-6-phosphate dehydrogenase, to chronic ingestion of chlorite.

## Methods

### Subject Selection

For Phase I and for Phase II, normal healthy adult male volunteers were selected. No prospective study participant who exhibited a significant abnormality in the routine clinical serum analysis,

---

\* The Department of Pharmacology, The Ohio State University, College of Medicine, 333 W. 10th Avenue, Columbus, OH 43210

blood count, urinalysis, or electrocardiogram was selected. Subjects manifested no physical abnormalities at the pretreatment examination, were 21 to 35 years of age, and weighed within  $\pm 10\%$  of normal body weight for their frame and stature. A history of disease or any medical or surgical condition which might interfere with the absorption, excretion, or metabolism of substances by the body precluded inclusion. Regular drug intake prior to the start of the investigation, either therapeutic or recreational, resulted in exclusion from the study. Normal methemoglobin levels, thyroid function, and glutathione levels were mandatory. Written informed consent was obtained from each subject prior to initiation of treatment.

For Phase III, volunteers were defined as glucose-6-phosphate dehydrogenase (G-6-PD)-deficient on the basis of a hemoglobin G-6-PD level of less than 5.0 IU/GM hemoglobin in the pre-study screening. Phase III subjects were normal in all other respects.

### Water Disinfectant Preparation

A detailed description of the water disinfectant preparation techniques has been presented by Lubbers and Bianchine (1). In general, freshly prepared stock solutions of chlorine dioxide, sodium chlorite, sodium chlorate, chlorine and chloramine were assayed by the colorimetric techniques of Palin (2) then diluted with organic-free demineralized deionized water to appropriate concentrations. Individual bottles were capped and stored in the dark under refrigeration until use. All bottles were coded by an independent observer and the identity of each bottle remained "double-blind" to both the investigative staff and the volunteer subjects.

### Study Design: Phase I

The 60 volunteers in Phase I were divided at random into six treatment groups (1). Ten persons were assigned to receive each of the disinfectants; the ten members of the control group received untreated water. The study involved a series of six sequences of three days each. Treatment concentrations were increased for each treatment. The specific concentrations or disinfectant administered to the study participants are listed in Table 1. A clinical evaluation of the collection of blood and urine samples for determination of pretreatment baseline laboratory values preceded the first treatment. On the first day of each three day treatment sequence, each volunteer ingested 1000 ml of the water in two portions. The second 500 ml portion aliquot was administered 4 hr after the first. Each 500 ml portion was consumed within 15 min. Only two doses of disinfectant were administered on the

first day of each treatment sequence. No disinfectant was administered on the second and third day of each sequence, since these two days were to serve as followup observation days. The second day of the treatment sequence consisted of a physical examination and collection of blood and urine samples for determination of posttreatment laboratory values. On the third day, each volunteer was given a physical examination to determine residual effects of treatment with the water disinfectants and byproducts.

Taste evaluations were obtained at each dose level. Study participants were asked to rate the treated water as very unpleasant, slightly unpleasant, not pleasant, pleasant, or tasteless.

### Study Design: Phase II

The sixty volunteers of Phase II were divided at random into six treatment groups of ten subjects each (3). In order to assure efficient management of the 60 subjects, they were randomly assigned to three subsets. These subsets were sequentially entered into the study on three successive days and exited from this study in a similar fashion. For all of the treatment groups, the concentration of disinfectants ingested was 5 mg/l. The control group received untreated water. Each subject received 500 ml daily for 12 weeks. Physicals, collection of blood and urine samples for laboratory assays, and taste evaluations were conducted on a weekly basis during the treatment period and for 8 weeks following cessation of treatment.

### Study Design: Phase III

The three glucose-6-phosphate dehydrogenase-deficient subjects of Phase III were given sodium chlorite at a concentration of 5 mg/l. chlorite (4). The treatment protocol was identical to that of Phase II, with daily administration of 500 ml of solution to each volunteer.

### Evaluation Procedures

An extensive battery of parameters was monitored to assess the biochemical and physiological response to the oral ingestion of the water disinfectants and water treatment by-products (Table 2). All laboratory determinations of biochemical parameters were conducted by a licensed medical laboratory, Consolidated Biomedical Laboratories, Inc. (CBL), Columbus, Ohio, HEW license number 34-1030. For each volunteer, pretreatment baseline values and six sets of posttreatment values were compiled. Laboratory tests were carefully chosen.

**Table 1. Concentration of disinfectants in phase I: acute rising dose tolerance.<sup>a</sup>**

Water disinfectant	Disinfectant concentration, mg/l.					
	Day 1	Day 4	Day 7	Day 10	Day 13	Day 16
Chlorate	0.01	0.1	0.5	1.0	1.8	2.4
Water control	0	0	0	0	0	0
Chlorine dioxide	0.1	1.0	5.0	10.0	18.0	24.0
Chlorite	0.01	0.1	0.5	1.0	1.8	2.4
Chlorine	0.1	1.0	5.0	10.0	18.0	24.0
Chloramine	0.01	1.0	8.0	18.0	24.0	

<sup>a</sup>For each dose, two portions of 500 ml each were administered at 4-hr intervals.

**Table 2. Biochemical parameters assayed in the controlled clinical evaluation of chlorine dioxide, chlorite and chlorate in man.**

Serum chemistry	Plasma glucose, sodium, potassium, chloride, urea nitrogen, creatinine, BUN/creatinine ratio, uric acid, calcium, phosphorus, alkaline phosphatase, gamma glutamyl transferase, total bilirubin, serum glutamic-oxaloacetic transaminase, serum glutamic-pyruvic transaminase, lactic dehydrogenase, cholesterol, triglycerides, total protein albumin, globulin, albumin/globulin ratio, iron
Blood count	Platelet count, white blood cell count, red blood cell count, hemoglobin, hematocrit, mean corpuscular volume, mean corpuscular volume, mean corpuscular hemoglobin, mean corpuscular hemoglobin concentration, high peroxidase activity, neutrophils, lymphocytes, monocytes, eosinophils, basophils, large unstained cells
Urinalysis	Color, <sup>a</sup> appearance, <sup>a</sup> specific gravity, pH, protein, sugar, <sup>a</sup> acetone, blood, <sup>a</sup> white blood count, red blood count, casts, <sup>a</sup> crystals, <sup>a</sup> bacteria, <sup>a</sup> mucus*, amorphous cells, <sup>a</sup> epithelial cells
Special tests	Serum haptoglobin, sickle cell, <sup>a</sup> methemoglobin, glucose-6-phosphate dehydrogenase, Coombs test, <sup>a</sup> hemoglobin electrophoresis, <sup>a</sup> T-3 (uptake), T-4 (RIA), free thyroxine index, electrocardiogram <sup>a</sup>
Physical exam	Systolic blood pressure, diastolic blood pressure, respiration rate, pulse rate, oral temperature

<sup>a</sup>These parameters yielded qualitative data only; no statistical analysis was performed.

On the basis of the literature (5–8), areas of suspected biochemical response to ingestion of chlorine oxidants were defined; a portion of the test battery was specifically devoted to monitoring this response. Red blood cell surface antibody formation was clinically monitored by the qualitative Coombs test; thyroid function by T-3 (uptake), T-4 (RIA), and free thyroxine; and response to oxidative stress by glucose-6-phosphate dehydrogenase, methemoglobin and glutathione levels. Hemoglobin electrophoresis was used to detect possible hemoglobin abnormalities. A battery of peripheral parameters was assayed to provide supplementary information and to assist in evaluation of overall physiological well-being. The specific serum, blood and urine parameters assayed have been discussed by Lubbers and Bianchine (1).

The numerical values obtained were collected and analyzed by utilizing the facilities of The Ohio State University Division of Computing Services for Medical Education and Research. Specially designed programs facilitated rapid clinical feedback. Any value for an individual subject which differed from the group mean by more than two standard deviations was noted. In addition, every individual value which fell outside normal labora-

tory ranges for that parameter was designated as abnormal. Chemical parameters for volunteers who exhibited abnormal values were subjected to careful scrutiny; the safety and the possibility of hypersensitivity to the disinfectant agents were evaluated for each of these individuals on a continuing basis throughout the study.

Statistical analyses utilized commercially available computer packages, specifically, the Biomedical Computer Programs (BMDP) and the Statistical Package for the Social Sciences (SPSS). Two-way analyses of variance with repeated measures utilized BMDP2V. BMDP1R was used to perform multiple linear regression analyses. For pairwise *t*-tests and simple *t*-tests, SPSS-*T*-test was employed.

## Results

### Qualitative

An important aspect of this study was the careful and continued medical observation of all subjects. The general clinical histories and physical examinations alone with subjective observations and qualitative laboratory tests throughout this study were accumulated in each subject's medical file. A careful

inspection of each of these medical files presented a review of the general clinical health of each subject.

The careful clinical evaluation of every subject in Phases I, II and III failed to reveal any clinically important impact upon the medical well-being of any subject as a result of disinfectant ingestion. Further, there was no apparent grouping of the minor subjective symptoms and objective signs noted throughout the study; the "colds," "lymphadenopathy," "sore throats" and "flu" problems noted episodically appear to be randomly dispersed among the treatment groups. All subjects remained negative with respect to the Coombs tests and the sickle cell tests during the investigation. Hemoglobin electrophoresis results indicated that, in Phase II, a small number of subjects yielded abnormal hemoglobin distributions but these individuals were found to be randomly distributed in both the treatment groups and in the control group. Examination of electrocardiograms revealed no abnormalities.

Vital signs (blood pressure, pulse rate, respiration rate and body temperature) were measured on a regular basis to provide immediate feedback to the monitoring physician on the acute physiological response of study participants to treatment. The statistical analysis of the vital signs was limited to the calculation of arithmetic group means and standard deviations from the mean. The compiled vital signs were examined for evidence of consistent response to treatment. No such evidence was found.

The subjective evaluations of palatability indicated that few subjects found the test substances to have an objectionable taste at levels up to 24 mg/l.

## Quantitative

For the Phase I acute rising-dose tolerance study, a two-way analysis of variance with repeated measures was used to compare the treatment group values of each biochemical parameter to the corresponding values of the control group. The analysis of variance allowed distinctions to be made among the possible sources of variation. Differences between two groups that existed prior to treatment, parallel variations in quantitative chemical values due to laboratory drift and authentic treatment-related changes in physiological parameters could be distinguished. Three probabilities were calculated for each case: the group main effect (G), the time main effect (R), and group-time interaction (RG). The treatment groups and the corresponding biochemical parameters for which a strong probability of treatment-related change was computed (that is,  $RG \leq 0.05$ ) are listed in the first column of Table 3.

To assist in determining the clinical importance of the statistically significant group time interactions, the group, mean and standard deviations

from the mean were examined for the pretreatment baseline assay and each posttreatment assay for each of the treatment groups. In all instances, the group mean values remain well within the established normal ranges.

On the basis of the small magnitude of change within the normal range and the duration of the study, it was concluded that the trends identified by the analysis of variance are unlikely to be of clinical importance. The possibility that the trends might become clinically important with increased exposure cannot be excluded.

Alternative statistical techniques were employed for Phase II. An omnibus testing technique was used initially. To test the hypothesis that the response of one or more of the groups was different to that of the rest of the groups, an analysis of variance with repeated measures was performed in which values for all six treatment groups were included. For the parameters urea nitrogen and mean corpuscular hemoglobin, RG-values  $< 0.05$  were obtained. Supplementary tests were performed. Analyses of variance with repeated measures in which the values of each treatment group were compared to the corresponding values of the control group were chosen. The use of the analysis of variance in this manner is flawed by the common control group. However, the results of the analyses may be used with caution. The analysis of variance yielded statistically significant RG-values in the comparison of the group mean corpuscular hemoglobin values for the chlorite and the chlorate groups and of the group mean urea nitrogen values of chlorate and chlorine dioxide treatment groups to the corresponding control group values, as shown in Table 3.

No linear trends were detected by linear regression analysis of the chlorite group's mean corpuscular hemoglobin values, the chlorate group's urea nitrogen levels or the chlorite group's urea nitrogen values.

Mean corpuscular hemoglobin levels in the chlorate group yielded a probability of 0.01 upon linear regression analysis. The relative slope associated with the change during the 12-week treatment period was approximately 1% of the normal physiological range per week. We believe that no physiological importance may be attributed with confidence to the variation. However, it is impossible on the basis of this study to rule out the potential physiological significance of the trend. Further study is warranted.

The small number of subjects (three) in Phase III negated the value of many statistical procedures. Linear regression analyses were chosen. The third column of Table 3 lists the biochemical parameters for which a high probability of change with respect to time was calculated. The  $p$ -values computed by

**Table 3. Biochemical parameters and treatment groups in which statistical analyses indicated a high probability of change which could be attributed to ingestion of disinfectant.**

Test	Phase I <sup>a</sup>	Phase II <sup>b</sup>	Phase III <sup>c</sup>
Urea nitrogen (BUN)	Chlorite	Chlorate Chlorine dioxide	
Creatinine	Chlorite		
BUN/creatinine Ratio	Chlorine Chlorite		
Uric acid	Chlorine dioxide		
Calcium	Chlorine		
Gamma glutamyl transferase	Chlorine		
Total bilirubin	Chlorate		
Albumin/globulin ratio			Chlorite
Iron	Chlorate		
Methemoglobin	Chlorate		Chlorite
T-4 (RIA)			Chlorite
Free thyroxine index			Chlorite
Mean corpuscular hemoglobin		Chlorite Chlorate	
Mean corpuscular hemoglobin concentration			Chlorite
Lymphocytes	Chlorine		

<sup>a</sup>Two-way analysis of variance yielded group-time interactions (RG values)  $\leq 0.05$  in comparisons of treatment group values to those of the control group.

<sup>b</sup>Two-way analysis of variance yielded group-time interactions (RG-values)  $\leq 0.05$  in both the omnibus and treatment group-control group comparisons.

<sup>c</sup>Linear regression analysis indicated a strong probability of change with respect to time;  $p$ -values  $\leq 0.05$ .

the linear regression analysis were less than 0.05 for four biochemical parameters. To gauge the relative magnitude of change, the percent change of the normal range per week was computed. These statistical analyses indicate a good probability that, for A/G ratio, T-4 (RIA), free thyroxine, mean corpuscular hemoglobin concentration, and methemoglobin values, a change with respect to time occurs during the 12-week treatment period. However, in the absence of a concurrent control group and taking into consideration the small group size and the possibility of laboratory drift, one must exercise caution in dealing with the results. We can say with confidence only that trends were indicated. We cannot say that these trends were of physiological origin nor can we attribute physiological consequence to them.

## Discussion

Several researchers have addressed the physiological effects of oral ingestion of the oxidizing agents, chlorine dioxide, chlorite and chlorate. Musil et al. (9) associated oral chlorite ingestion with methemoglobin formation. In studies by Heffernan et al. (7,8), Abdel-Rahman et al. (5) and Couri et al. (6), hemolytic anemia and suppressed glutathione levels were observed in animals treated with chlorite. The oral administration of chlorate to laboratory animals has been shown to induce oxidative destruction of hemoglobin and methemoglobin for-

mation (10, 11). The possibility of renal toxicity at high levels of chlorite ingestion was suggested by the increased kidney/body weight ratio reported by Heffernan et al. (7). Haller and Northgraves (12) and Fridlyand and Kagan (13) examined the chronic toxicity of orally consumed chlorine dioxide in rats; a slightly increased two-year mortality rate and a decreased rate of weight gain were observed. Oral administration of chlorite (14-16) to mice was shown to increase mean corpuscular volume, osmotic fragility, and glucose-6-phosphate dehydrogenase activity of erythrocytes; morphologic changes were reported. In the African Green monkey, chlorine dioxide adversely affected thyroid function; chlorite ingestion yielded transient changes in hemoglobin levels and red cell count (17). The maternal toxicity, embryonic toxicity and the teratogenic potential of concentrations of sodium chlorite was evaluated in rats (18).

Unfortunately, the information available on the impact of chlorine dioxide, chlorite, and chlorate ingestion in man is severely limited. Epidemiological studies (19,20) have failed to conclusively identify any significant exposure related effects. The clinical evaluation described in this report was an attempt to elucidate the effects of the chlorite, chlorine dioxide and chlorate in man under controlled clinical conditions.

During the course of the three-phase study, a massive volume of raw data was acquired. Routine urinalyses were performed and a meticulous exam-

ination of this body of information was made. No definitive finding of detrimental physiological impact was made in any of the three phases of this human investigation of the relative safety and tolerance of oral chlorine disinfectant ingestion. In several cases, statistically significant trends were associated with treatment; however, none of these trends were judged to have immediate physiological consequence. One cannot rule out the possibility that, over a longer treatment period, these trends might indeed achieve proportions of clinical importance. However, within the limits of the study, the relative safety of oral ingestion of chlorine dioxide and its metabolites, chlorite and chlorate, was demonstrated by the absence of detrimental physiological response.

#### REFERENCES

1. Lubbers, J. R., and Bianchine, J. R. The effects of the acute rising dose administration of chlorine dioxide, chlorate and chlorite to normal healthy adult male volunteers. *J. Environ. Pathol. Toxicol.* 5 (2, 3): 865-878 (1982).
2. Palin, A. T. Methods for the determination, in water of free and combined available chlorine, chlorine dioxide and chlorite, bromine, iodine and ozone, using diethyl-*p*-phenylene diamine (DPD). *J. Inst. Water Engr.* 21: 537-549 (1976).
3. Lubbers, J. R., Chauhan, S., Miller, J. K., and Bianchine, J. R. The effects of chronic administration of chlorine dioxide, chlorite and chlorate to normal healthy adult male volunteers. *J. Environ. Pathol. Toxicol.* 5 (2, 3): 879-888 (1982).
4. Lubbers, J. R., Chauhan, S., Miller, J. K. and Bianchine, J. R. The effects of chronic administration of chlorite to glucose-6-phosphate dehydrogenase deficient healthy adult male volunteers. *J. Environ. Pathol. Toxicol.* 5 (2, 3): 889-892 (1982).
5. Abdel-Rhman, M. S., Couri, D., and Bull, R.J. Kinetics of  $\text{ClO}_2$  and effects of  $\text{ClO}_2$ , and  $\text{ClO}_2^-$ , and  $\text{ClO}_3^-$  in drinking water on blood glutathione and hemolysis in rat and chicken. *J. Environ. Path. Toxicol.* 3(1,2): 431-449 (1979).
6. Couri, D., and Abdel-Rahman, M.S. Effect of chlorine dioxide and metabolites on glutathione dependent system in rat, mouse and chicken blood. *J. Environ. Pathol. Toxicol.* 3(1,2): 451-460 (1979).
7. Heffernan, W. P., Guion, C., and Bull, R. J. Oxidative damage to the erythrocyte induced by sodium chlorite *in vitro*. *J. Environ. Pathol. Toxicol.* 2(6): 1487-1499 (1979).
8. Heffernan, W. P., Guion, C., and Bull, R. J. Oxidative damage to the erythrocyte induced by sodium chlorite *in vitro*. *J. Environ. Pathol. Toxicol.* 2(6): 1501-1510 (1979).
9. Musil, J., Kontek, Z., Chalupa, J., and Schmidt, P. Toxicological aspects of chlorine dioxide application for the treatment of water containing phenol. *Chem. Technol. Praha.* 8: 327-345 (1964).
10. Richardson, A. P. Toxic potentialities of continued administration of chlorate for blood and tissues. *J. Pharmacol. Exptl. Therap.* 59: 101-103, (1937).
11. Jung, F., and Kuon, R. Zum inaktiven hemoglobin das Bluter. *Naunyn-Schmiedebergs Arch. Exptl. Pathol. Pharmacol.* 216: 103-111 (1951).
12. Haller, S. F., and Northgraves, W.W. Chlorine dioxide and safety. *TAPPI* 33: 199-202 (1955).
13. Fridyland, S. A., and Kagan, G. Z. Experimental validation of standards for residual chlorine dioxide in drinking water. *Hygiene Sanitation* 36: 18-21 (1971).
14. Moore, G. S., and Calabrese, E. J. The effects of chlorine dioxide and sodium chlorite on erythrocytes of A-J and C-57L-J mice. *J. Environ. Pathol. Toxicol.* 4(2, 3): 513-524 (1980).
15. Moore, G. S. and Calabrese, E. J. G-6-PD-deficiency—a potential high-risk group to copper and chlorite ingestion. *J. Environ. Pathol. Toxicol.* 4(2, 3): 271-279 (1980).
16. Moore, G. S., Calabrese, E. J. and Ho, S. C. Groups at potentially high-risk from chlorine dioxide treated water. *J. Environ. Pathol. Toxicol.* 4(2, 3): 465-470 (1980).
17. Bercz, J. P., DiBiasi, D. L., Jones, L., Murray, D., and Boston, J. Subchronic toxicity of alternate disinfectants and related compounds in the non-human primate. *Environ. Health Perspect.* 46: 47-55 (1982).
18. Couri, D., Miller, C. H., Bull, R. J., Delphia, J. M., and Ammar, E. M. Assessment of maternal toxicity, embryotoxicity and teratogenic potential of sodium chlorite in Sprague-Dawley rats. *Environ. Health Perspect.* 46: 25-29 (1982).
19. Haring, B. J., and Zoetman, B. C. Corrosiveness of drinking water and cardiovascular disease mortality. *Bull. Environ. Contam. Toxicol.* 25: 658-662 (1981).
20. Michael, G. E., Miday, R. K., Bercz, J. P., Miller, R. G., Greathouse, D. G., Kraemer, D. F., and Lucas, J. B. Chlorine dioxide water disinfection: a prospective epidemiology. *Arch. Environ. Health* 36(1): 20-27 (1981).

## Overview of Chlorine Dioxide (ClO<sub>2</sub>)

The compound chlorine dioxide (ClO<sub>2</sub>), now commercially important, is not in fact a recent discovery. The gas was first produced by Humphrey Davy in 1811 when reacting hydrochloric acid with potassium chlorate. This yielded "euchlorine", as it was then termed. Watt and Burgess, who invented alkaline pulp bleaching in 1834, mentioned euchlorine as a bleaching agent in their first patent. Chlorine dioxide then became well known as a bleach and later a disinfectant. Since the beginning of the twentieth century, when it was first used at a Spa in Ostend, Belgium, ClO<sub>2</sub> has been known as a powerful disinfectant of water. The production of ClO<sub>2</sub> from the chlorate is complicated however, and the gas is explosive, so that it could not be easily utilized practically until the production of sodium chlorite by Olin Corporation in 1940. Chlorine dioxide could now be released when necessary from the chlorite salt. In municipal water supplies this is usually done by adding chlorine to the chlorite solution, and in the laboratory by adding an acid to the chlorite solution. Alliger showed in 1978,<sup>1,2</sup> that ClO<sub>2</sub> could be applied topically by the individual user.

Although ClO<sub>2</sub> is a strong oxidizing agent and a particularly fast disinfectant, there are no reports in the scientific literature of toxicity by skin contact or ingestion, or moreover of mutagenicity. It would seem that effective application of this compound as a topical medication for skin diseases,<sup>3,4</sup> as a disinfectant on food, as well as a cold sterilant on instruments and glassware, is long overdue.

ClO<sub>2</sub> in some respects is chemically similar to chlorine or hypochlorite, the familiar household bleach. However, ClO<sub>2</sub> reactions with other organic molecules are relatively limited as compared to chlorine. When ClO<sub>2</sub> is added to a system – whether a wound or a water supply – more of the biocide is available for disinfection and not consumed by other materials.<sup>5,6</sup> Until 1963 hypochlorite was a standard product of the British Pharmacopoeia (for skin medications), and burn patients even now are bathed in hypochlorite solution at some U.S. burn centers. However, for many reasons ClO<sub>2</sub> makes a likely substitute for the better known hypochlorite since it is far less toxic and irritating when applied to the human body. ClO<sub>2</sub> for example, does not hydrolyze to form HCl as does chlorine, but remains a true gas dissolved in solution. ClO<sub>2</sub>, unlike chlorine or hypochlorite, does not form chlorinated hydrocarbons when in contact with organic matter, or readily add to double bonds. This is a prime concern since many chlorinated hydrocarbons are known to be carcinogenic. Of the amino acids, the building blocks of proteins, only aromatic amino acids and those containing sulfur react with ClO<sub>2</sub>. When hypochlorite is applied to the skin, nitrogen trichloride is formed, a compound which appears in trace quantities but is toxic and irritating. Also, hypochlorite in swimming pool water produces chloramine, an eye irritant, and in wastewater, chloroform. Lastly, unlike hypochlorite or chlorine, ClO<sub>2</sub> can treat water at about 10 ppm with no harmful effects to fish. The LC50 for rainbow trout at 96 hours is 290 ppm.<sup>7</sup> For this reason ClO<sub>2</sub>, rather than chlorine, is favored in commercial aquarium water, especially in mammal tanks.<sup>8</sup>

Residuals of available chlorine in effluents from sewage treatment plants, including the hypochlorite ion and chloramines, adversely influence aquatic life in receiving waters ---



the potential adverse effects both on the public health and on aquatic ecosystems due to increased exposure to chlorinated compounds suggests that the use of chlorine relative to other available techniques for the treatment of sewage and other waste-waters must be reevaluated.<sup>9</sup>

At the time of World War I, when Dakins Solution (0.5% hypochlorite) gained fairly wide acceptance as a wound disinfectant, ClO<sub>2</sub> was not similarly adopted as there was, again, no easy way to produce the gas in small quantities, or to transport it. The application of ClO<sub>2</sub> to the body is still not practiced, nor does it seem particularly obvious that it can be. The gas needs to be released or "activated", normally done with strong acids or chlorine just before use. This process appears somewhat unattractive therefore as a disinfectant in the lab or as a home remedy for the skin. Further, once ClO<sub>2</sub> is activated, shelf life is normally on the order of hours.

**{GRAPH NOT SHOWN}**

#### DECAY OF CHLORINE DIOXIDE IN FRESHWATER

From: Development and Evaluation of an Ion Chromatographic Method for Measuring Chlorite and Chlorate Anions in Bleached Kraft Mill Effluent, NCASL technical bulletin #673, July 1994, p. 3

However, in dilute solutions, in a closed container and absence of light, ClO<sub>2</sub> can remain stable for long periods. This is especially the case in chilled water.

A new compound, DIOXIDERM (formerly CITRONEX) disinfectant gel, makes novel use of ClO<sub>2</sub> and is available as a "skin cream" in a two-part system.<sup>10</sup> The amount to be applied is mixed just before use, and the chlorine dioxide is released slowly. Because disinfection and lesion response are so rapid, the needed extra step of mixing seems unimportant, especially when treating diseases such as diabetic ulcers or pox lesions. Dual or co-dispensers simplify the application. Similarly, a dual toothpaste and mouthwash, DIOXIBRITE and DIOXIRINSE are now available which kill all bacteria and deodorize the mouth. DIOXIGUARD Liquid for instrument and hospital application as well as general topical use, is a fast acting disinfectant. The shelf life after combining the needed quantity is one day. DIOXIGUARD kills all bacteria, viruses and fungi within one minute, including mycobacteria and amoeba.

#### WIDE USE OF CHLORINE DIOXIDE IN INDUSTRY

Paper mills in the U.S. generate an enormous quantity of  $\text{ClO}_2$ , 500 tons daily for bleaching pulp.<sup>11</sup> Although more expensive than chlorine, it is the bleach material of choice because the basic properties of cellulose are not altered. The textile industry applies  $\text{ClO}_2$  similarly, where prevention of injury to the fibers is important. Both cellulosic and synthetic materials are processed in this way, including cottons, acetates, rayons, polyesters, acrylics and nylons. Cotton is not degraded because the oxidation reaction is highly selective toward lignin and hemicellulose components of the fiber.  $\text{ClO}_2$  does not adversely effect old paper prints or drawings, and will clean ancient documents without injury to fibers.

The first use of chlorine ( $\text{Cl}_2$ ) as a water treatment process in the U.S. occurred in Jersey City in 1908<sup>12</sup>, and of chlorine dioxide, at Niagara Falls in 1944.<sup>13</sup>  $\text{ClO}_2$  now purifies water in over 500 water treatment facilities in the U.S.<sup>14</sup> and many more in Europe. Only chlorine dioxide among the common water treatment disinfectants (ozone, chlorine, chloramine, and chlorine dioxide), produces no signs of malignancy in test animals.<sup>15</sup>  $\text{ClO}_2$  is often applied for water treatment other than disinfection, for example, remedying difficult smell and taste problems. Phenols, in particular, are quickly oxidized, and without odorous chlorophenols often produced by chlorine.  $\text{ClO}_2$  is considered the best additive for oxidizing iron and manganese impurities in drinking water, and for eliminating taste and odor due to algae.<sup>16</sup> It also removes cyanides sulfides, aldehydes and mercaptans.  $\text{ClO}_2$  as used in water disinfection is more sporicidal than  $\text{Cl}_2$ <sup>17,18</sup>, a more powerful inactivator of viruses<sup>19</sup>, and inactivator of cysts.<sup>20</sup> In storm water overflow,  $\text{ClO}_2$  has proved active toward all viruses examined.<sup>21</sup>

Another application of  $\text{ClO}_2$  is in the bleaching of fats and flour.<sup>22</sup>

Extensive experience with chlorine dioxide bleaching of tallow (the fat extracted from meat scraps and dead animals) has shown that this is a safe chemical bleaching process. The chlorine dioxide selectively converts color bodies to lighter colored ones without substantial attack on natural antioxidants in the oil which protect it against aging and rancidity. Tallows bleached with Chlorine dioxide meets the "Refine and Bleach Test", is color stable, and is now in use for the manufacture of the highest-grade toilet soaps.<sup>23</sup>

Many nutrition and toxicology studies have been performed assessing chlorine dioxide's effect on flour. Treatment of flour with 200 ppm, fed to rats, had no effect after several generations.<sup>24,25</sup> Flour treated with up to 500 ppm (5 times the concentration in DioxiCure Gel) fed to puppies had no untoward effect.<sup>26</sup> Thirteen human subjects fed experimentally for six weeks with flour products that were treated with doses up to 400 ppm had no detectable toxic symptoms.<sup>27</sup> Flour bleached with normal dosage is not reduced appreciably in nutritive value.<sup>28</sup> Essential fatty acids are generally not effected, but tocopherol and cystine are oxidized.<sup>29</sup> Reactivities of 21 amino acids with  $\text{ClO}_2$  were evaluated using an iodometric assay, only 6 were found to be reactive at pH 6. They were cysteine, histidine, hydroxyproline, proline, tryptophan and tyrosine.<sup>76</sup>

Several other applications within the food industry have been described. The first reported use of  $\text{ClO}_2$  in the canning industry was by Green Giant at LeSueur, Mn. more than 30 years ago. The objective was to conserve water while at the same time control bacteria.<sup>30</sup> When  $\text{ClO}_2$  rather than chlorine is added to process waters recirculated to clean potatoes, starch by-product, previously extracted for gluing cartons, is upgraded to food grade level and a higher market value. Also, the fresh water need is reduced 25%. In this particular process 10 ppm  $\text{ClO}_2$  is added to the wash water in order to maintain a 1 ppm residual.<sup>31</sup> Chlorine dioxide is excellent as a commercial disinfectant in turkey egg sanitation, and its use does not modify the hatching properties of the fertile eggs.<sup>32</sup> The shelf life of tomatoes can be improved by treatment with  $\text{ClO}_2$ .<sup>33</sup>  $\text{ClO}_2$  also finds application in bleaching cherries and as a teat dip for cows to prevent mastitis. The FDA has recently permitted the use of  $\text{ClO}_2$  for disinfecting chickens, beef and fruits and vegetables.

Masschelein, in his book Chlorine Dioxide, cites the following:

Chlorine dioxide destroys the microorganisms in fish, fruits and vegetables; and the treatment can be carried out without altering the nutritive and organoleptic qualities of the foodstuff. It will take place either by 30-minute immersion in an aqueous solution of 50 to 1,000 mg/l (50 to 1000ppm) of  $\text{ClO}_2$  or by exposure to air containing 2,000 to 3,000 ppm of  $\text{ClO}_2$ . This is a very favorable treatment for the storage of frozen foods. Natural foods such as pepper may be sterilized by a treatment with air containing 1,000 to 20,000 ppm of  $\text{ClO}_2$ . The preservation of melted cheese is facilitated by the addition of 100 to 300 mg/l of  $\text{ClO}_2$  to the milk used for its manufacture, and 100 to 400 mg/l to its washing water. The bleaching of oils and greases, particularly those used for alimentary needs, is carried out by a maximum injection of 20,000 mg/l of  $\text{ClO}_2$ . The medicinal odor of cleaning shrimps is eliminated by adding 40 mg/l to the washing water. A dose of less than 100 mg/l of  $\text{ClO}_2$  does not seem to hinder the taste or nutritive value.<sup>34</sup>

The remaining or residual products on fruits and vegetables after treatment with  $\text{ClO}_2$  are apparently chloride and a trace amount of chlorite.<sup>35</sup> A recent patent by Frontier Pharmaceutical involves the lowering of the chlorite residual, and describes a method for the release of  $\text{ClO}_2$  at higher, more physiological pH.

Some industrial applications of  $\text{ClO}_2$  other than bleaching or disinfecting include: the treatment of leather, where  $\text{ClO}_2$  oxidizes disulfide bridges of keratin; stabilization of vinyl and latex enamels; additive in air pollution control for complexing impurities such as mercaptans and aldehydes; controlling odors of fishmeal and rendering plant water effluents; an oxidant in the preparation of vaccines<sup>36,37</sup> and neutralizing toxins<sup>38</sup>; and a copper etchant in the manufacture of electronic component parts.

## DIFFERENCES WITH OTHER OXIDANTS

Although chlorine and chlorine dioxide are both strong oxidizing agents, they differ in reactions with various organic and inorganic compounds.  $\text{ClO}_2$  for example, does not combine with ammonia as does  $\text{Cl}_2$ . Chlorine dioxide is a better disinfectant in the presence of organic matter, and bacterial kill is not appreciably changed with change in pH. Hypochlorite has a higher oxidation potential and is an indiscriminate "chlorinator", adding a permanent chlorine atom to organic molecules. This unfortunately, produces a number of unwanted chlorinated hydrocarbons such as chloroform and chlorophenol. Chemicals found in industrial waste discharges for example, all react to produce chlorinated by-products that are hazardous to health.<sup>39</sup>  $\text{ClO}_2$ , on the other hand, oxidizes (removes electrons) without adding an atom of its own to the oxidized product. The pKa for the chlorite ion, chlorous acid equilibrium, is extremely low at pH 1.8. This is different from the hypochlorous acid/hypochlorite base ion pair equilibrium found near neutrality, and indicates the chlorite ion will exist as the dominant species in drinking water and in the human body.

When purifying water supplies,  $\text{ClO}_2$  combines with phenols particularly fast by attacking the benzene ring. Odorless, tasteless products are formed directly, without intermediate compounds, as is the case with chlorine.<sup>40</sup>  $\text{ClO}_2$  may be more effective than copper sulfate in controlling algae; it is believed to attack the pyrrole ring of the chlorophyll which cleaves the ring and leaves the chlorophyll inactive. The reaction of  $\text{ClO}_2$  with algae, again, forms tasteless, odorless products.

Olefins react much more rapidly with permanganate than with chlorine dioxide, whereas, triethylamine is thousands of times more reactive with chlorine dioxide than with permanganate.

Unlike most other oxidizing compounds,  $\text{ClO}_2$ , and its reduction product  $\text{ClO}_2^-$ , can act either as oxidizing or reducing agents (NCASI No. 673). Under acid conditions hydrogen peroxide will reduce  $\text{ClO}_2$  to form chlorous acid, but  $\text{ClO}_2$  also can be oxidized by chlorine to produce chlorate, and by ozone to produce  $\text{Cl}_2\text{O}_6$ .  $\text{ClO}_2^-$  similarly can oxidize iodide to form iodine, or be oxidized by hypochlorite ion to form chlorate. Combining  $\text{ClO}_2$  with blood causes methemoglobin by oxidizing  $\text{Fe}^3$  to  $\text{Fe}^2$  in the red blood cell. Breathing  $\text{ClO}_2$  can have this effect.

When  $\text{ClO}_2$  oxidizes organics, it usually takes in one electron and reduces to  $\text{ClO}_2^-$ .  $\text{ClO}_2$  can oxidize some inorganics, like ferric oxide, remove 5 electrons rather than one, and reduce all the way to chloride. The amount of electron exchange is the oxidizing capacity, not the redox potential or driving force of the reaction.

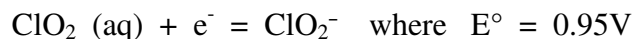

When oxidizing organic molecules, there is no chlorine atom exchange to produce chlorinated hydrocarbons.

## CHEMICAL REACTIONS<sup>41,42,43,44</sup>

### Preparation of $\text{ClO}_2$

1. Acidification of chlorite

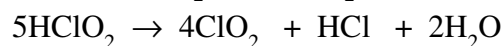
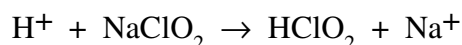

2. Oxidation of chlorite by hypochlorite - for alkaline bleaching & water treatment



3. Oxidation of chlorite by chlorine

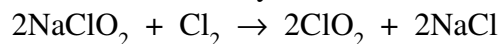

4. Reduction of chlorate with sulfur dioxide - used in pulp bleaching

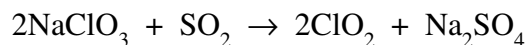

5. Oxidation of chlorite by persulfate

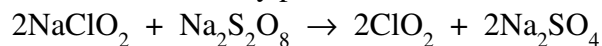

6. Reduction & acidification of chlorate by oxalic acid

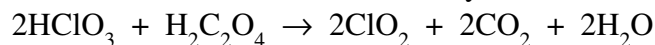

To inhibit further oxidation, the following are good scavengers of  $\text{ClO}_2$ : sulfamic acid, sulfur dioxide, resorcinol, hydroquinone, sodium thiosulfate, sodium bisulfite, sodium sulfite, sodium arsenite and plumbous oxide. Agents that reduce  $\text{ClO}_2$  completely to the chloride ion: borohydride, iodide at pH 1, sulfurous acid, ferrous chloride manganese and vitamin C. Ferrous chloride will eliminate chlorate.

{GRAPH NOT SHOWN}

UV-Vis absorption spectra showing the release of  $\text{ClO}_2$  from sodium chlorite at various pH values. Readings were taken after 60 minutes at ambient temperature. The initial chlorite concentration was 112 ppm. Notice the loss of chlorite at 262 nm as the pH is lowered, with the gain of  $\text{ClO}_2$  at 360 nm. There is little or no release of  $\text{ClO}_2$  above pH 3.<sup>45</sup>

Inorganic Reactions:

- For iodometric analysis  

$$2\text{ClO}_2 + 2\text{I}^- \rightarrow 2\text{ClO}_2^- + \text{I}_2$$
- Oxidation of iron  

$$\text{ClO}_2 + \text{FeO} + \text{NaOH} + \text{H}_2\text{O} \rightarrow \text{Fe}(\text{OH})_3 + \text{NaClO}_2$$
- Oxidation of manganese  

$$2\text{ClO}_2 + \text{MnSO}_4 + 4\text{NaOH} \rightarrow \text{MnO}_2 + 2\text{NaClO}_2 + \text{Na}_2\text{SO}_4 + 2\text{H}_2\text{O}$$
- Oxidation of sodium sulfide  

$$2\text{ClO}_2 + 2\text{Na}_2\text{S} \rightarrow 2\text{NaCl} + \text{Na}_2\text{SO}_4 + \text{S}$$
- Oxidation of nitrogen oxide pollutant  

$$2\text{NO} + \text{ClO}_2 + \text{H}_2\text{O} \rightarrow \text{NO}_2 + \text{HNO}_3 + \text{HCl}$$
- Gas phase reaction with flourine  

$$\text{F}_2 + 2\text{ClO}_2 \rightarrow 2\text{FClO}_2$$
- In alkaline solution  

$$2\text{ClO}_2 + 2\text{OH}^- \rightarrow \text{ClO}_2^- + \text{ClO}_3^- + \text{H}_2\text{O}$$
- Aluminum, magnesium, zinc & cadmium react with  $\text{ClO}_2$   

$$\text{M} + x\text{ClO}_2 \rightarrow \text{M}(\text{ClO}_2)_x$$
- Disproportionation of chlorite depends upon chlorides present, pH, and ratio of ingredients  

$$4\text{ClO}_2^- + 4\text{H}^+ \rightarrow \text{Cl}^- + 2\text{ClO}_2 + \text{ClO}_3^- + 2\text{H}^+ + \text{H}_2\text{O}$$

$$5\text{ClO}_2^- + 4\text{H}^+ \rightarrow 4\text{ClO}_2 + \text{Cl}^- + 2\text{H}_2\text{O}$$
- With hydrogen peroxide as a reducing agent in commercial production of chlorite  

$$2\text{ClO}_2 + \text{H}_2\text{O}_2 + 2\text{NaOH} \rightarrow 2\text{NaClO}_2 + 2\text{H}_2\text{O} + \text{O}_2$$
- A highly colored complex is formed when  $\text{ClO}_2$  is dissolved in an aqueous solution of barium chlorite  $\text{ClO}_2 + \text{ClO}_2^- \rightleftharpoons \text{Cl}_2\text{O}_4$

### Organic Reactions:

- With organic compounds in water  $\rightarrow$  aldehydes, carboxylic acids, ketones & quinones
- With olefins  $\rightarrow$  aldehydes, epoxides, chlorohydrins, dichloro-derivatives, and chloro-and unsaturated ketones.
- With ethylenic double bonds  $\rightarrow$  ketones, epoxides, alcohols
- With benzene  $\rightarrow$  no reaction
- With toluene  $\rightarrow$   $\text{CH}_3$ ,  $\text{CH}_2\text{Cl}$ ,  $\text{CH}_2\text{OH}$
- With anthracene  $45^\circ$   $\rightarrow$  anthraquinone, 1, 4-dichloroanthracene
- With phenanthrene  $\rightarrow$  diphenic acid, 9-chlorophenanthrene
- With 3, 4-benzopyrene  $\rightarrow$  quinones, traces of chlorinated benzopyrene  
(no longer considered carcinogenic)
- With carboxylic and sulfonic functions  $\rightarrow$  no reaction
- With aldehydes  $\rightarrow$  carboxylic acids

11. With ketones → alcohols
12. With aliphatic amines
 

primary	→ slow or no reaction
secondary	→ slow or no reaction
tertiary	→ rupture of CN bond, no N-oxides formed
13. With triethylamine
 
$$\text{H}_2\text{O} + (\text{C}_2\text{H}_5)_3\text{N} + 2\text{ClO}_2 \rightarrow (\text{C}_2\text{H}_5)_2\text{NH} + 2\text{ClO}_2^- + \text{CH}_3\text{CHO} + 2\text{H}^+$$
14. With phenol → P-benzoquinone, 2 chlorobenzoquinone
15. Excess  $\text{ClO}_2$  with phenol → maleic acid, oxalic acid
16. With thiophenols → sulfonic acids
17. With tocopherol → demethylated derivatives
18. With saturated acids → no reaction
19. With anhydrides → no reaction but catalyzes hydrolysis
20. With amino acids: glycine, leucine, serine, alanine, phenylalamine, valine, hydroxyproline, phenylaminoacetec, aspartic, glutamic acids → little, or no reaction
21. With amino acids containing sulfur → reactive
22. With methionine → sulfoxide → sulfone
23. With aromatic amino acids → reactive
24. With tyrosine → dopaquinone, dopachrome
25. With tryptophan → idoxyl, isatine, indigo red, trace chlorinated products
26. With thiamine → slow reaction
27. With keratin → hydrosoluble acids
28. With carbohydrates CHO and  $\text{CH}_2\text{OH}$  → carboxylic functions
29. With vanillin pH4 → monomethyl ester,  $\beta$ -formylmuconic acid
30. With pectic acid → mucic acid, tartaric acid, galacturonic acid
31. With chlorophyll and plant dyes → color removed.
32. With latex and vinyl enamels → delays polymerization
33. With naphthaline → no reaction
34. With ethanol → no reaction
35. With biacetyl → acetic acid, carbon dioxide
36. With 2,3-butaneodiol → acetic acid, carbon dioxide
37. With cyclohexene → aldehydes, carboxylic acids, epoxides, alcohols, halides, dienes, ketones
38. With maleic acid → no reaction
39. With fumaric acid → no reaction
40. With crotonic acid → no reaction
41. With cyanides → oxidized
42. With nitrites → oxidized
43. With sulfides → oxidized

Hydrocarbons of longer chain length than  $\text{C}_8$  are the most oxidizable by  $\text{ClO}_2$ .<sup>46</sup>

The organic compounds most reactive with  $\text{ClO}_2$  are tertiary amines and phenols.

Unsaturated fatty acids and their esters are generally oxidized at the double bond.

#### $\text{ClO}_2$ DOES *NOT* REACT WITH:

hippuric acid, cinnamic acid, betaine, creatine, alanine, phenylalanine, valine, leucine, asparaginic acid, asparagine, glutaminic acid, serine, hydroxyproline, taurine, aliphatically combined  $\text{NH}_2$  groups, amido and imido groups, HO groups in alcohols and HO acids, free or esterified  $\text{CO}_2\text{H}$  groups in mono and polybasic acids, nitrile groups, the  $\text{CH}_2$  groups in homologous series, ring systems such as  $\text{C}_6\text{H}_6$ ,  $\text{C}_{10}\text{H}_8$ , cyclohexane, and the salts of  $\text{C}_5\text{H}_5\text{N}$ , quinoline and piperidine.

Most aliphatic and aromatic hydrocarbons do not react with  $\text{ClO}_2$  under normal water treatment conditions, unless they contain specific reactive groups. Alcohols are resistant at neutral pH, but under conditions of very low pH, high temperatures or high concentrations, alcohols can react to produce their corresponding aldehydes or carboxylic acids.<sup>47</sup>  $\text{ClO}_2^-$ , chlorite, the reduction product of  $\text{ClO}_2$ , although a less powerful oxidant, is used to react with many malodorous and highly toxic compounds such as unsaturated aldehydes, mercaptans, thioethers, hydrogen sulfide, cyanide and nitrogen dioxide.

**{GRAPH NOT SHOWN}**

UV-Vis absorption spectra<sup>43</sup> for:

- a commercial “stabilized chlorine dioxide oral rinse” at a concentration of 100 ppm chlorite at pH 6.5 (there is no release of chlorine dioxide shown at 360 nm)
- a solution of sodium chlorite ( $\text{ClO}_2^-$ ) at 900 ppm in a phosphate buffer at pH 7
- a sodium chlorate ( $\text{ClO}_3^-$ ), at 900 ppm in a phosphate buffer at pH 7

**{GRAPH NOT SHOWN}**

Uv-Vis spectra of commercially available RetarDex® oral rinse utilizing “stabilized chlorine dioxide” at pH 6.5, 5.15, and 2.2. No  $\text{ClO}_2$  is evolved above pH 5 as shown at 360 nm.<sup>43</sup>



## DIOXIDERM AND DIOXIGUARD EXPERIMENTAL DISINFECTANTS

Studies have shown DIOXIGUARD and DIOXIDERM, which are  $\text{ClO}_2$  or  $\text{ClO}_2$  complexes, to be two of the fastest disinfectants.<sup>48</sup> Bacteria, viruses and even fungi are killed in under 1 minute. This rate of deactivation includes mycobacteria, amoeba and spores (non dried). Two questions immediately come to mind: How does DIOXICURE and DIOXIGUARD work? And, why are they not toxic?

The method of chlorine dioxide bacterial kill at low ppm concentration seems to occur by the disruption of protein synthesis and enzyme inactivation.<sup>49 50</sup> This is similar to the "time honored", non-toxic mechanism of some common antibiotics. Oxidation of RNA and DNA do not appear to take place, or are at least unimportant in the process. The site of action lies in the soluble fraction of the cell; there appears to be no damage to whole structural components such as ribosomes.<sup>51</sup> Bringmann prepared electron micrographs of chlorine-treated cells immediately after contact and observed no visual change in the cells, comparable to those killed with bromine and iodine.<sup>52</sup>

At high  $\text{ClO}_2$  ppm, the method of rapid bacterial and viral kill appears to be the softening and destroying of the cell wall or viral envelope.<sup>53</sup> Human cells do not have cell walls and are apparently unaffected. Our skin and bodies are likely protected from the general oxidative effects of  $\text{ClO}_2$  by the many reducing agents in our cells and blood such as catalase, glutathione, superoxide dismutase, vitamins E, C, A, B complex, uric acid, zinc and selenium. This is probably the same internal protective mechanism that prevents damage from oxygen and free radicals. Bacteria and viruses do not contain most of these reducing compounds.

Because  $\text{ClO}_2$  is a strong oxidizing agent and also itself a free radical, it quickly neutralizes reactive molecules, and oxygen free-radicals that are produced in the body by macrophages such as,  $\text{NO}^\bullet$ ,  $\text{O}_2^-$ ,  $\text{H}_2\text{O}_2$ ,  $\text{HClO}$ , and  $\text{OH}^\bullet$ . These oxygen compounds are released in response to stress or infection and cause inflammation and pain. Other potential irritants found in wounds are similarly oxidized or reduced, such as leukotrienes, TNF, and interleukin. This neutralizing property of  $\text{ClO}_2$ , combined with its ability to completely disinfect, makes DIOXIDERM and DIOXIGUARD ideal wound medications. Unlike iodine compounds, healing is not impeded.<sup>54</sup> Veterinarians have been treating deep wounds and abscesses on tigers and elephants as well as dogs and cats with outstanding success.<sup>56</sup> DIOXIDERM GEL had similar striking results on human (otherwise non-healing) diabetic ulcers.<sup>57</sup> If our body could manage to manufacture chlorine dioxide, as it does hypochlorite, hydrogen peroxide and superoxide, it would certainly do so.

$\text{ClO}_2$  is both a small molecule relative to common organic disinfectants and soluble. It is also a gas and non-ionic. These properties no doubt facilitate the transporting process through the skin or bacterial cell wall.

It is interesting to speculate on the formation of a  $\text{ClO}_2$  complex that may be involved in the disinfection process. Electron configuration of the  $\text{ClO}_2$  molecule theoretically allows combination.  $\text{ClO}_2$  will hydrate for example with water, and also can form compounds with the chlorite ion  $[\text{ClO}_2 \cdot \text{ClO}_2^-]^-$ .<sup>58</sup> A highly colored complex,  $\text{C}_2\text{O}_4^-$ , is formed when  $\text{ClO}_2$  is dissolved in a solution of barium chlorite. There is evidence that more than one oxidant in a disinfectant formula will act synergistically in deactivating microorganisms,<sup>59</sup> for example chlorous acid and chlorine dioxide.

As with household bleach, where hypochlorous acid and not chlorine is the active bacteria killer, it may similarly be chlorous acid although quite unstable, and not chlorine dioxide, which is the more active of the two species. Chlorous acid has a higher oxidation/reduction potential than either  $\text{ClO}_2$  or hypochlorous acid. In Frontier's particular case, DIOXIDERM GEL maintains the chlorous acid concentration since the unstable chlorous acid molecules formed when mixing A & B are far less mobile within a viscous gel matrix. The chlorous molecules can not as easily combine and evolve chlorine dioxide as would be the case in a liquid. The increase in chlorous acid may be the reason that the gel form is the faster disinfectant on wounds and burns. The chemical literature shows that a chlorite/acid mixture producing  $\text{ClO}_2$  has many more times the oxidation power than  $\text{ClO}_2$  alone at similar pH.<sup>60</sup> Interesting too, that the type of acid activator producing the chlorous acid molecule can have an effect on the oxidizing strength of  $\text{ClO}_2$ , or  $\text{ClO}_2$  mixture.<sup>61</sup>

{GRAPH NOT SHOWN}

Comparison of the Disinfection Efficiencies  
of  $\text{ClO}_2$  with  $\text{Cl}_2$  at pHs of 6.5 and 8.5<sup>62</sup>

Comparison of the Dosage Required to Achieve  
a 5-Log Reduction in Viable Bacteria at 60-  
Second Contact Time<sup>63</sup>

## NON-TOXICITY

Many evaluations have shown  $\text{ClO}_2$  compounds to be non-toxic. Five decades of use have not indicated any adverse effects on health. The main areas of use have been disinfecting water supplies, the elimination of unwanted tastes and odors, and bleaching in the pulp and paper and textile industries. Toxicology tests include ingestion of  $\text{ClO}_2$  in drinking water, additions to tissue culture, injections into the blood, seed disinfection<sup>64,65</sup>, insect egg disinfection, injections under the skin of animals and into the brains of mice, burns administered to over 1500 rats, and injections into the stalks of plants. "Standard" tests include, Ames Mutation, Chinese Hamster, Rabbits Eye, Skin Abrasion, Pharmacodynamics and Teratology.<sup>66</sup> In one tissue culture study, highly diluted DioxiDerm liquid was placed on CD4 cells infected with H.I.V.<sup>67</sup> Viruses were inactivated inside the cell, as well as in the supernatant, and with

little damage to the CD4 cell itself. Daughter cells 6 days later, although not as viable as the controls, were not infected. This is particularly impressive considering that most virucides are cytotoxic, even at high dilutions. Similar efficacy and non toxicity was demonstrated on infected cabbage seeds. 4000 seeds heavily infected with bacteria were soaked for about ½ hour in ClO<sub>2</sub> disinfectant. No bacteria remained after this period, and the seeds then grew normally.<sup>68</sup> In order to reduce air and water pollution the EPA is proposing to substitute chlorine dioxide for the usual chlorine bleach in all pulp and paper mills throughout the country. This effects 350 installations and costs the industry about \$4 billion.<sup>69</sup> With a prospect of changing from chlorine to chlorine dioxide in our water supply, the EPA and American Water Works in the past have commissioned over 100 papers and studies on the toxicity of ClO<sub>2</sub>. Many controlled animal studies on the effects of ingesting sodium chlorite and chlorine dioxide have been conducted from 1 to 1000 mg/L concentrations. Metabolically, both ClO<sub>2</sub> and ClO<sub>2</sub><sup>-</sup> are rapidly reduced following ingestion. Radioactive chlorine tests show that most of the tagged chlorine is excreted from the urine in the form of Cl<sup>-</sup> ion with a small amount of ClO<sub>2</sub><sup>-</sup>. The no observed effect level, NOEL, from animal ingestion studies involving ClO<sub>2</sub> and ClO<sub>2</sub><sup>-</sup>, ranges to 100 ppm<sup>70,71,72</sup>, about the concentration of Frontier's DioxiDerm gel for topical use. The half life for the elimination of ClO<sub>2</sub> and ClO<sub>2</sub><sup>-</sup> from the plasma is less than half that of HOCl, hypochlorite.<sup>73</sup>

In one study, human volunteers drank ClO<sub>2</sub> or ClO<sub>2</sub><sup>-</sup> in solution up to 24 ppm and showed no adverse effects.<sup>74</sup> Several studies examined the effects on reproductive toxicity or teratology. There is no evidence of fetal malformation or birth defects at ClO<sub>2</sub> concentrations, in drinking as well as skin route, up to 100 ppm.<sup>75 76 77</sup> With prolonged feeding toxicity is produced mainly in the red blood cell. Rats fed up to 1000 mg/l chronically for 6 months showed no significant hematological changes. After 9 months, however, red blood cell counts, hematocrit and hemoglobin were decreased in all treatment groups.

Lack of toxicity on a long term, but low level basis is dramatically illustrated by two separate studies where rats,<sup>78</sup> and honeybees,<sup>79</sup> were fed ClO<sub>2</sub> in high doses over a two year period. No ill effects were noted with up to 100 ppm added to water supply.

In a skin sensitization study, ClO<sub>2</sub> liquid and gel (similar to DIOXIDERM ) were injected intradermally into guinea pigs, 10 times in about 3 weeks.<sup>80</sup> No sensitivity reaction was observed. At the site of continuous liquid injection, necrotic areas developed due to the low pH of 2.7. This damage was reversible. The pH of Frontier's DIOXIDERM GEL and DIOXIDERM Liquid, however, is much higher at pH 4, and would probably avoid this temporary damage. An ocular irritation study in rabbits indicated redness in the conjunctivae after one hour, which became normal after 24 hours. The cornea and iris remained unchanged after treatment.

Fast disinfection and non-toxicity are properties normally not found side-by-side in the same compound. For example, formaldehyde and peracetic acid are strong and often used sterilants, but they are also toxic and irritating. Because both speeds of deactivation and non-toxicity are combined in DIOXIDERM biocides, new possibilities are opened for important skin products, as well as commercial surface disinfection.

## REFERENCES

- <sup>1</sup> Alliger Patents: # 4,084,747, # 4,330,531
- <sup>2</sup> Block, S.S., *Disinfection, Sterilization and Preservation*, **1983**, 3rd edition, Lea & Febiger, 172
- <sup>3</sup> Kenyon A.J., DVM, PhD; Hamilton,S.G., B.A.; Douglas, D.M., B.S., Comparison of Antipseudomonad Activity of Chlorine Dioxide/Chlorous Acid-Containing Gel with Commercially Available Antiseptics, *Amer. Journal of Vet. Research*, **1986**, 47, No. 5, 1101-1104,
- <sup>4</sup> Kenyon, A. J.; Hamilton, S. G.; Douglas, B.S.; Controlled Wound Repair in Guinea Pigs, Using Antimicrobials that Alter Fibroplasia, *Amer. J. of Vet. Res.*, **1986**. 47, No. 1, pp 96-101
- <sup>5</sup> Ingols, R.S.; Ridenour, G.M., *Chemical Properties of Chlorine Dioxide*, J. Amer. Water Works Assoc., **1940**, 40, 1207
- <sup>6</sup> Sussman, S.; Ward, W.J., *Microbiological Control with Chlorine Dioxide Helps Save Energy* MP, 16(7), 24, **1977**
- <sup>7</sup> Acute Toxicity of Sodium Chlorite to Rainbow Trout, Toxicity, Test Report #BW-79-1-387, Jan. **1979**, E G & G Bionomics Aquatic Toxicology Laboratory, Wareham, Mass.
- <sup>8</sup> Dempster, R. P., Steinhart Aquarium Publications, Sept. **1970**
- <sup>9</sup> Dugan, P. R., Use and Misuse of Chlorination for the Protection of Public Water Supplies, *ASM News*, **1979**, 44, No. 3, 101
- <sup>10</sup> Alliger, Patent 4,330, 531
- <sup>11</sup> Gall, R. J., Chlorine Dioxide, An Overview of its Preparation, Properties and Uses, Hooker Chemicals & Plastic Corp., Niagra Falls, N. Y., 2
- <sup>12</sup> Dugan, P. R., Use and Misuse of Chlorination for the Protection of Public Water Supplies and the Treatment of Wastewater, *ASM News*, **1978**, 44, No. 3
- <sup>13</sup> White, G. C., Handbook of Chlorination, Van Nostrand Reinhold, New York, N. Y., **1972**, 744
- <sup>14</sup> Harrington, R.M.; Romano, R.R.; Gates, D., Subchronic Toxicity of Sodium Chlorite in the Rat, *J. Am. College of Tox.* 14 (1): 21-33
- <sup>15</sup> Ozone, Chlorine Dioxide and Chloramines as Alternatives to Chlorine for Disinfection of Drinking Water, *Water Supply Research*, **1977**, U.S. Environmental Protection Agency, Cincinnati, Ohio
- <sup>16</sup> Ridenour, G.M.; Ingols, R.S.; Armbruster, E.H., *Water Sewage Works* **1960**, 97:R83
- <sup>17</sup> Ibid 12
- <sup>18</sup> Berndt, H.; Linneweh, H.J., *Arch. Hyg. Bacterial.* **1969**, 153, 41
- <sup>19</sup> Carlson, S.; Gas u., *Wasserfach*, **1965**, 106, 32
- <sup>20</sup> Ingols, R.S., *J. Inst. Water Engrs.* **1950**, 4:581
- <sup>21</sup> Smith, J.E.; McVey, J.L. Prepr. Pap. Natl. Meeting, Div. Envir. Chem.; Am. Chem. Soc., **1973**, 13:177; Chem. Abstr. **1975**, 82:159955
- <sup>22</sup> FDA Reg: 21CFR 137.105: Other government Regs: FDA, Indirect Food Additives, 21CFR 175, 21CFR 178.1010(6) (34), 21CFR 186.1750. EPA, Safe Drinking Water Act, 40CFR 141, 40CFR141.72, 40CRF 141.74. Exemption from Tolerances on Raw Agricultural Commodities, 40CRF 180.**1070**
- <sup>23</sup> Upgrading Inedible Fats with Chlorine Dioxide, Olin Chemicals, Product Data Bulletin, Ad-2127-974
- <sup>24</sup> Frazer, A.C., et al, *J. Sci. Food Agr.*, **1956**, 7, 464
- <sup>25</sup> Hutchinson, J. B., et al, *J. Sci. Food Agr.*, **1964**, 15, 725

- 
- <sup>26</sup> Nakamura, F. I.; Morris, M. L., *Cereal Chemical*, **1949**, 26, 50120
- <sup>27</sup> Newell, G. W., *Cereal Chemical*, **1949**, 26:160
- <sup>28</sup> Graham, W. D. et al, *J. Pharm. Pharmacol.*, **1954**, 6, 534
- <sup>29</sup> Moran, T.; Pace, J.; McDermott, E.E., *Nature*, **1953**, 171, 103
- <sup>30</sup> Field Report, Chlorine Dioxide Gains Favor as Effective Sanitizer, *Food Engineering*, March **1977**
- <sup>31</sup> Bruce, D.J.; Stevens, P.B, Chlorine Dioxide Key to Successful Retrograde Water System, *Food Processing*, April **1977**
- <sup>32</sup> Ernst, R.A., et al, *Poult Sci.*, **1974**, 53, 14926
- <sup>33</sup> Rahman, R.A. et al, *U. S. Natl. Tech. Inform. Serv.*, **1974**, Ref. No. 746, 254, Chem. Abstr., vol. 78: 28144, 1973
- <sup>34</sup> Masschelein, W. J., *Chlorine Dioxide*, Ann Arbor Science, **1979**, 172
- <sup>35</sup> Thomas, R., Use of ClO<sub>2</sub> in Water Treatment of Fruits and Vegetables, *FDA GRAS petition 3G0020*, **1979**
- <sup>36</sup> Weislow, O. S.; Wheelock, F., Suppression of Established Friend Virus Leukemia by Statolon: Potentiation of Statolon's Leukemiosuppressive Activity by Chlorite-Oxidized Oxyamylose, *Infection & Immunity*, Jan. **1979**, 129-136
- <sup>37</sup> Hermon, O.S.; Janis, B.; Levy, H.B., Post-Exposure Prophylaxis of Murine Rabies with Polyinosinic-Polycytidylic Acid and Chlorite-Oxidized Amylose, *Antimicrobial Agents and Chemotherapy*, **1974**, 507-511
- <sup>38</sup> Brazis, A. R., et al, *J. Amer. Water Works Assoc.*, **1959**, 51, 902
- <sup>39</sup> *Ibid.*, 5, 100
- <sup>40</sup> Stevens, A.; Seeger, D.; Slocum, C., *Products of Chlorine Dioxide Treatment of Organic Materials in Water*, Water Supply Research Div., U. S. Environmental Protection Agency, Cincinnati, Ohio, **1977**, 9
- <sup>41</sup> Ozone, Chlorine Dioxide and Chloramines as Alternatives to Chlorine for Disinfection of Drinking Water, *Water Supply Research*, **1977**, U.S. Environmental Protection Agency, Cincinnati, Ohio
- <sup>42</sup> Masschelein, W. J., *Chlorine Dioxide*, **1979**, Ann Arbor Science Publishers, Inc.
- <sup>43</sup> Gordon, G.; Kieffer, R.; Rosenblatt, D., The Chemistry of Chlorine Dioxide, *Progress in Inorganic Chemistry*, Wiley-Interscience Publishers, **1972** 15, 201-286
- <sup>44</sup> *Ibid.*, 9, 612-631
- <sup>45</sup> Lynch, E.; Sheerin, A.; Claxson, A.W.; Atherton, M.D.; Rhodes, C.J.; Silwood, C.J.L.; Naughton, D.P.; Grootveld, M. *Free Rad. Res.*, **1997**, 26, 209-234
- <sup>46</sup> Gordon, G., Kieffer, R. & Rosenblatt, D., The Chemistry of Chlorine Dioxide, *Progress in Inorganic Chemistry*, Wiley-Interscience Publishers, **1972**, 37, 60
- <sup>47</sup> Harrington, R. M., Gates, D., and Romano, R.R., A Review of the Uses Chemistry and Health Effects of Chlorine Dioxide and the Chlorite Ion. *Chlorine Dioxide Panel of the Chemical Manufacturers Association*, Washington, D.C., Apr. **1989**. 15
- <sup>48</sup> Evaluations available by Nelson Labs., BioScience Labs., Liuzzi Microbiology Labs., and the University of Tennessee Inst. of Agr.
- <sup>49</sup> Benarde, M. A.; Snow, B. W.; Olivieri, V. P.; Davidson, B., Kinetics and Mechanism of Bacterial Disinfection of Chlorine Dioxide, *Appl. Microbiol.*, **1957**, 15, 257-265

- 
- <sup>50</sup> Scatina, J.; Abdel-Rahman, M. The Inhibitory Effect of Alcide, an Antimicrobial Drug, on Protein Synthesis in *E. Coli*, *J Appl. Tox.*, **1985**, 5, 6,
- <sup>51</sup> Olivieri, V., Chlorine Dioxide and Protein Synthesis, **1968**, Master's Degree Thesis, West Virginia University
- <sup>52</sup> Bringmann, G., Electron Microscopic Findings of the Action of Chlorine, Bromine, Iodine, Copper, Silver and Hydrogen Peroxide on *E. coli*; *Z. Hyg. Infektionskrankh.*, **1953**, 138, 156-166
- <sup>53</sup> E. M. Photos supplied by Frontier Research, Inc. on request
- <sup>54</sup> Kenyon, A.J.; Hamilton, S., Wound Healing Studied with Alcide: a Topical Sterilant, Amer. Society of Biol. Chemists 74<sup>th</sup> Annual Meeting, San Francisco, CA June 5-9 **1983**.
- <sup>55</sup> Kenyon, A.J.; Hamilton, S.G.; Douglas, D.M., Controlled Wound Repair By Antimicrobials That Alter Fibroplasia, Amer Assn. For Laboratory Animal Science, 34<sup>th</sup> Annual Session Nov. 6-11, **1983**.
- <sup>56</sup> Veterinary reports supplied by Arco Research, Inc. upon request.
- <sup>57</sup> Reports available from *Frontier Pharmaceutical, Inc.*, 135 Spagnoli Rd. Melville, N.Y. 11747, tel. 631-777-1420, fax 631-777-1422
- <sup>58</sup> *Ibid.*, 37
- <sup>59</sup> White, J.F.; Taylor, M.C.; Vincent, G.P., Chemistry of Chlorites, *Industrial and Engineering Chemistry*. July, **1942**, 789
- <sup>60</sup> *Ibid.*, 51
- <sup>61</sup> Paluch, K.; Otto, J.; Starski, R., Investigations on Reactions of Chlorine Dioxide and Sodium Chlorite with some Organic Compounds, *Roczniki Chemii, Ann. Soc. Chim. Polonorum*, **1974**, 48, 1456
- <sup>62</sup> Bernarde, M.A.; Israel, B.M.; Olivieri, V.P.; Grandstrom, M.L., Efficiency of Chlorine Dioxide as a Bactericide, *Appl. Microbiol.*, Sept. **1965**, 13, 776
- <sup>63</sup> Tanner, R.S., Comparative Testing and Evaluation of Hard-Surface Biocides, *Jour. Ind. Microbiology*, **1989**, 4, 145
- <sup>64</sup> Kawada, Hiroshi, Haneda, Tadayoshi, Soil Disinfection by Using Aqueous Chlorine Dioxide Solutions, Patent application: JP95-111095 13 Apr **1995**.
- <sup>65</sup> Report from Cornell, available from Frontier Pharmaceutical, Inc. upon request.
- <sup>66</sup> *Ibid* 49
- <sup>67</sup> Pontani, D.R., The In Vitro Effect of DioxiDerm on HIV,
- <sup>68</sup> *Ibid* 49
- <sup>69</sup> EPA Seeks Increase in Chlorate, O<sub>2</sub> Use, *Chemical Marketing Reporter*, Nov 8, **1993**
- <sup>70</sup> Bull, R. J. et al., Carcinogenic Activity of Reaction Products of Alternate Drinking Water Disinfectants, *Pharmacologist*, **1979**, 21, No.3, 218
- <sup>71</sup> Yokose, Y.; Uchida, K.; Nakae, D.; Shiraiwa, K.; Yamamoto, K.; Konishi, Y., Studies of Carcinogenicity of Sodium Chlorite in B6C3F1 Mice, *Env. Health Perspectives*, **1987**, 76, 205-210
- <sup>72</sup> Final Draft Drinking Water Criteria Document on Chlorine Dioxide, Chlorite and Chlorate , EPA contract No. 68-C2-0139, Clement International Corp., March 31, **1994**
- <sup>73</sup> Bull, R.J., Health Effects of Drinking Water Disinfectants and Disinfectant By-Products, *Envir. Sci. Tech.*, **1982**, 16
- <sup>74</sup> *Ibid.*, 41, 38

- 
- <sup>75</sup> Suh, D.H.; Abdel-Rahman, M.S.; Bull, R.J., Effect of Chlorine Dioxide and Its Metabolites in Drinking Water of Fetal Development in Rats, *J. Appl. Toxicol.* **1983**, *3*, 75-79
- <sup>76</sup> Tuthill, R.W.; Guisti, R.A.; Moore, G.S.; Calabrese, F.J., Health Effects Among Newborns After Prenatal Exposure to ClO<sub>2</sub> Disinfected Drinking Water, *Envir. Health Perspect*, **1982**, *46*, 39-45,
- <sup>77</sup> Gerges, A.-R., Skowronski, Effects of Alcide Gel on Fetal Development on Rats and Mice, *J. of Applied Tox.*, **1985**, *5*, No. 2
- <sup>78</sup> Haag, H.B., The Effects on Rats of Chronic Administration of Sodium Chlorite and Chlorine Dioxide in Drinking Water, Med. Col. Virginia, Dept. Phys. & Pharm., Report to Olin Corp., February 7, 1949
- <sup>79</sup> Lockett, J., Oxodene: Longevity of Honey Bees, *Journal of Econ. Entomology*, vol. 65, No. 1, Feb. 1972
- <sup>80</sup> Abdel Rahman, M.S., Gerges S.E., Alliger, H., Toxicity of Alcide, *J. Applied Toxicology*, Vol. 2, No. 3, 1982
- <sup>76</sup> Tan, H.K., Wheeler, W.B., Wei, C.I., Reaction of chlorine dioxide with amino acids and peptides, *Mutation Research*, 188: 259-266, 1987